

BOY SCOUT

H A N D B O O K



BOY SCOUTS OF AMERICA

AMERICA

SERVICE
STARS



$\frac{3}{8}$ "

$\frac{3}{4}$ "

TEMPLATE TO CHECK POSITION OF ALL POCKET INSIGNIA

TEMPORARY and
LOCAL COUNCIL
INSIGNIA



RIGHT
POCKET

BADGES
OF RANK

LEFT POCKET



CRUITER

WEBELOS
BADGE



Colby Dickson



Seventh Edition • Third Printing

\$1.00

An illustration of a Boy Scout campsite. In the foreground, a large green tent is pitched on a grassy field. A Scout in a brown uniform and hat stands to the right, carrying a bundle of sticks. In the background, another tent is visible, and two more Scouts are near it. The scene is set in a forest of tall pine trees, with a lake and snow-capped mountains in the distance under a blue sky with light clouds. The word "BOY SCOUT" is printed in large, bold, black letters across the top of the illustration.

BOY SCOUT

A HANDBOOK OF TRAINING FOR CITIZENSHIP
THROUGH SCOUTING

Seventh Edition • Third Printing, January 1967 • 600,000
TOTAL PRINTING SINCE 1910—22,375,000

BOY SCOUTS OF AMERICA

H A N D B O O K

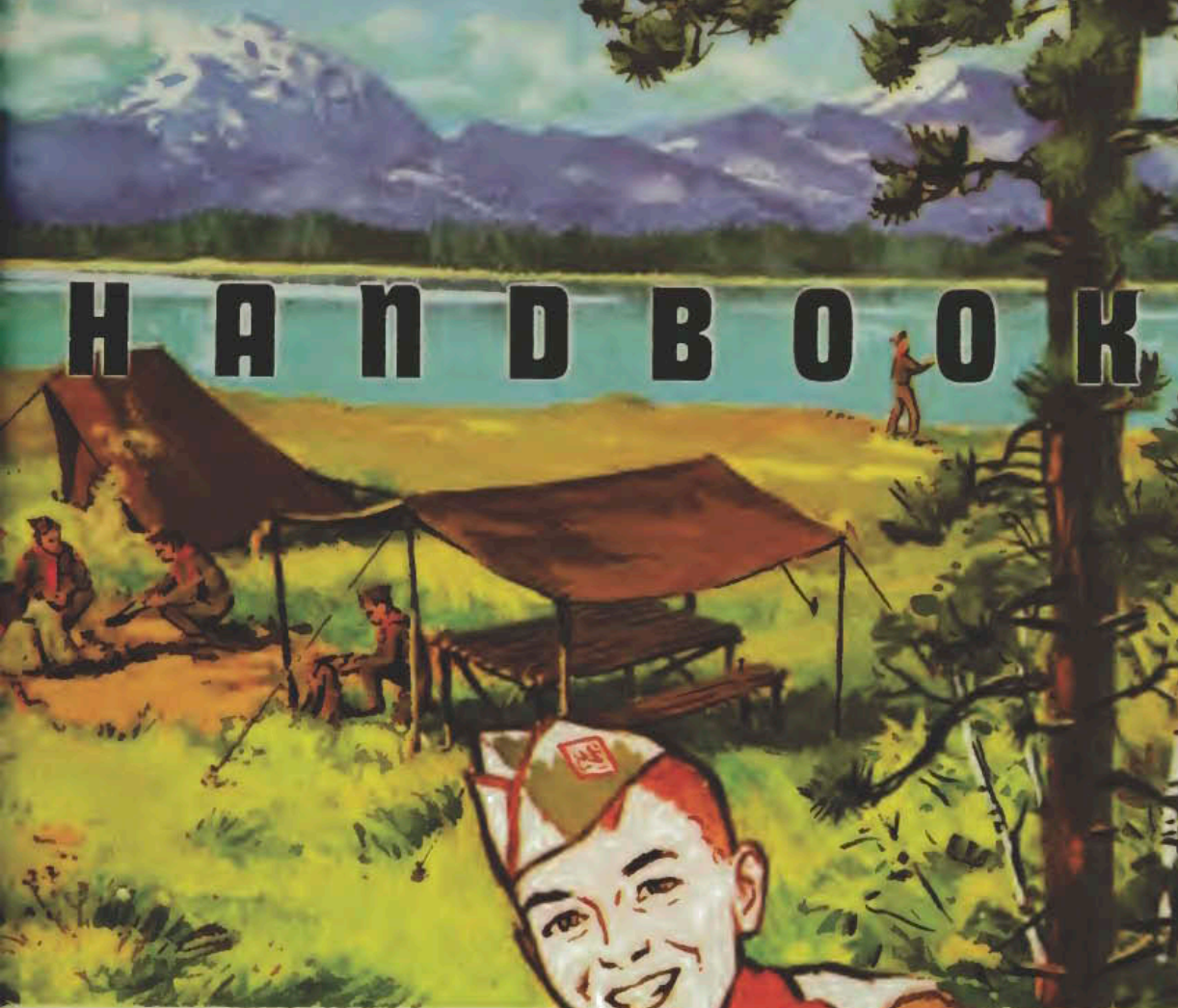



This book, based on the experience of the
Boy Scouts of America in the United States
since its founding in 1910, was developed
under the auspices of

Thomas J. Watson, Jr., President
Joseph A. Brunton, Jr., Chief Scout Executive

Copyright 1965

BOY SCOUTS OF AMERICA

New Brunswick New Jersey

No. 3227 Printed in U.S.A.

Library of Congress Catalog Card Number: 11-15620

C O N T E N T S

Starting Trail to TENDERFOOT

- | | | | |
|--------------------------|----|-----------------------|----|
| Tenderfoot Tests | 34 | Our Country's Flag | 65 |
| The Spirit of Scouting | 36 | Knots | 74 |
| Outward Signs of a Scout | 54 | Protect the Outdoors | 83 |
| The Scout Uniform | 56 | Your Life in Scouting | 88 |
| Scout Badge | 62 | | |

Hiking Trail to SECOND CLASS

- | | | | |
|----------------------|-----|-------------------------------------|-----|
| Second Class Tests | 102 | Trailing, Tracking,
and Stalking | 160 |
| Your Life as a Scout | 106 | The Tools of a Woodsman | 170 |
| Let's Go Hiking | 110 | Your Hike Meal | 176 |
| Find Your Way | 126 | Emergency Preparation | 186 |
| Lost | 137 | Scout Spirit | 206 |
| Get To Know Nature | 140 | | |

Camping Trail to FIRST CLASS

- | | | | |
|------------------------|-----|---------------------------|-----|
| First Class Test | 231 | Woodlore | 288 |
| Your Life as a Scout | 234 | Go Swimming | 296 |
| To Camp! | 238 | Get a Message Through | 300 |
| Your First Class Camps | 248 | Be Prepared for Accidents | 310 |
| Mapping | 278 | Scout Spirit | 330 |
| The Stars in the Sky | 284 | Adventure Camping | 334 |

Advancement Trail to EAGLE

- | | | | |
|-------------------------|-----|--------------------------|-----|
| Merit Badges | 357 | Eagle Scout Requirements | 367 |
| Star Scout Requirements | 363 | Other Scout Awards | 368 |
| Life Scout Requirements | 365 | Merit Badge Groups | 370 |

Scouting Trail to CITIZENSHIP

- | | | | |
|------------------------|-----|----------------------|-----|
| From Boy to Man | 379 | Helping Other People | 405 |
| Duty to God | 381 | Physically Strong | 410 |
| Duty to Country | 385 | Mentally Awake | 426 |
| Obedying the Scout Law | 404 | Morally Straight | 436 |

- Once a Scout Always a Scout 437
Books You'll Enjoy Reading 440



How to use this BOY SCOUT HANDBOOK

This book is designed to be your guide toward becoming a good Scout and a good American citizen. It will serve you best when you use it correctly.

When a well-trained Scout sets out on a wilderness hike, he first decides on his goal. Next, he considers the whole route ahead of him. He then breaks down the route into laps along the way. Finally, he sets his compass — and takes off. Follow the same procedure in using this handbook.

Start by making your goal clear to yourself by going through the whole book, paying special attention to the section "From Boy to Man," page 379. Next, find out about the laps along the Scouting road: the ranks of Tenderfoot, Second Class, First Class, the whole way to Eagle. Then — and only then — take your first definite step along the road by passing your first test. After that it's simply a matter of one step after another until the goal is reached.

Luck and happiness to you along the way!

"Tomorrow's Leader"
By Norman Rockwell



To YOU as a Scout

"I suppose every boy wants to help his country in some way or other. There is a way by which he can do so easily, and that is by becoming a Boy Scout."

Those are the opening words of the World Brotherhood edition of *Scouting for Boys*—the book written by Baden-Powell that started the Boy Scout movement on its early conquest of the boyhood of the world 60 years ago.

When the Boy Scouts of America was founded in 1910, one of the most urgent jobs of the founders was to develop a handbook on Scouting suitable for the boys of the United States of America. This first handbook for American Scouts was published in July 1910. Since then it has been printed in more than 22 million copies.

The BOY SCOUT HANDBOOK has always kept in step with the changing times and with new developments. The book you hold in your hands this moment is the very latest, updated version of it, designed specifically for the American boy of today. This means YOU.

I hope that for years to come this book will be your companion as you follow the rugged road of Scouting. Read it well and often because every time you do you will find new paths to knowledge, to fun, and to adventure. It will help you in your outdoor activities. It will show you what you need to do to advance in Scouting. It will tell you of the ideals of a Scout and will challenge you to live up to the Scout Oath and Law. It will help you become a true American citizen.

Even though this is your personal handbook, share it with your friends who are not Scouts; invite them to join you in the game of Scouting. Upon your shoulders and those of young fellows like you, as you grow into manhood, will rest the hope of the free world. Scouting can help you BE PREPARED for that great responsibility. I trust you ON YOUR HONOR to strive to become the kind of a Scout and the kind of a citizen that our country and the world needs and deserves.

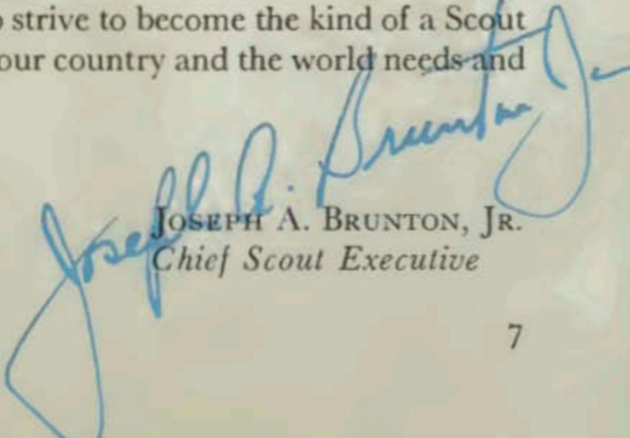

JOSEPH A. BRUNTON, JR.
Chief Scout Executive

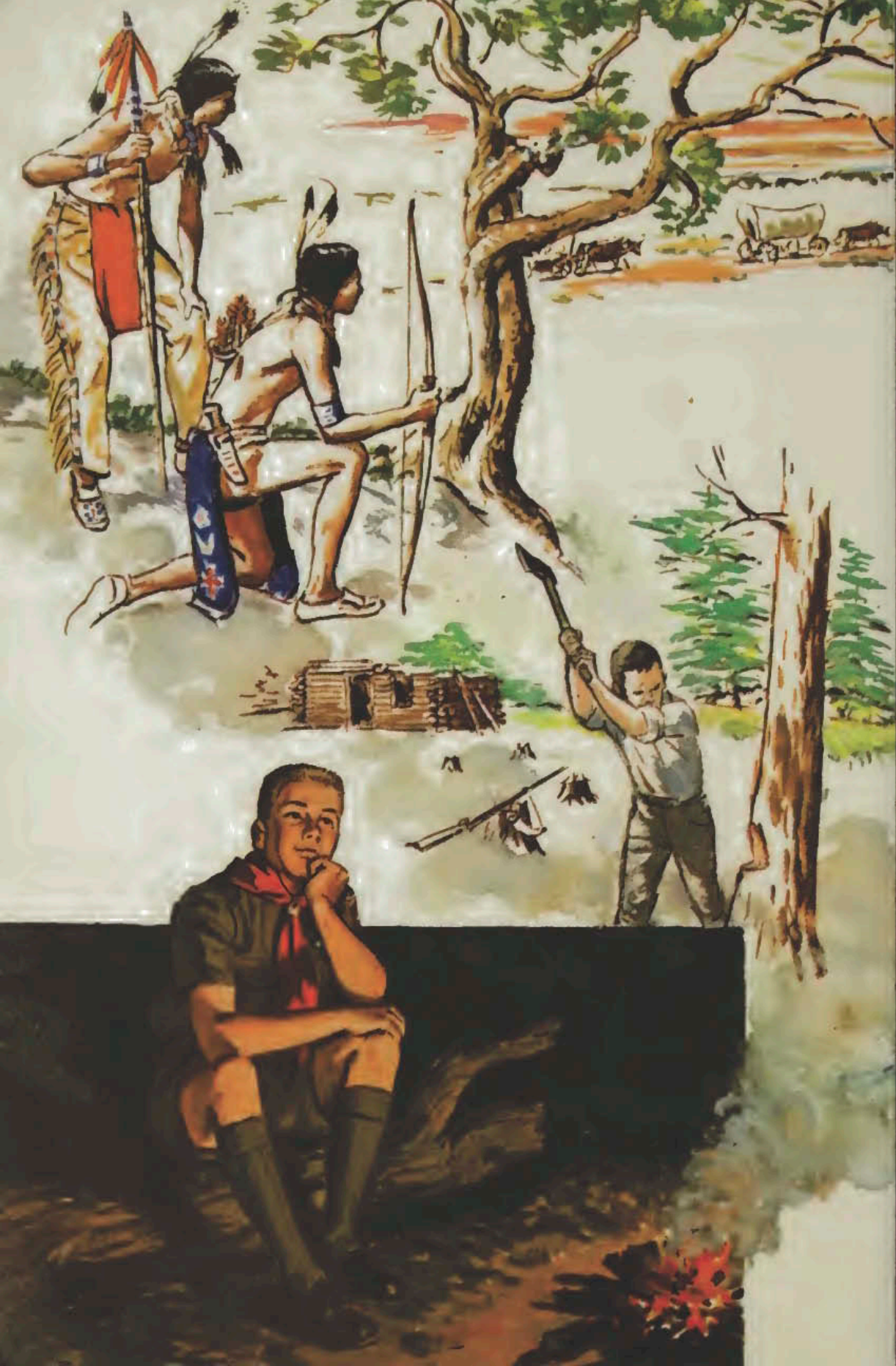



YOU — AMERICAN BOY

Have you ever dreamed of hiking the wilderness trails that were worn down under moccasins hundreds of years ago? Do you hear in your imagination the almost soundless dip-dip of Indian canoe paddles or the ring of the ax of an early pioneer hewing a home out of the American wilderness? Have you followed with your mind's eye the covered wagons on the trek across our continent? Have you thought of the men and women who built our country by their determination and devotion?

You are the descendant of those people. You are the guardian of what they built. You are the American on whom the future of our wonderful country depends.







YOU — BOY SCOUT

Today you are an American boy. Before long you will be an American man. It is important to America and to yourself that you become a citizen of fine character, physically strong, mentally awake, and morally straight.

Boy Scouting helps you become that kind of citizen. But also, Scouting gives you fellowship and fun.

Yes, it's fun to be a Boy Scout! It's fun to go hiking and camping with your best friends . . . to swim, to dive, to paddle a canoe, to wield an ax . . . to follow in the footsteps of the pioneers who led the way through the wilderness . . . to raise your eyes to the heavens . . . to stare into the glowing embers of a campfire and dream of the wonders of the life that is in store for you . . .





YOU — IN THE GREAT OUTDOORS

When you are a Scout, forests and fields, rivers and lakes are your playground. You are completely at home in God's great outdoors. You learn to notice every sound, to observe every track. Birds and animals become your friends. You master the skills of walking noiselessly through the woods, of stalking close to a grazing deer without being noticed, of bringing a bird to you by imitating its call. You learn to find your way cross-country by map and compass, to make a meal when you are hungry, to take a safe swim when you are hot, to make yourself comfortable for the night in a tent or under the stars. You become a true outdoorsman.





YOU — PATROL MEMBER

As a Boy Scout you will belong in a patrol—which is the Scout name for a small gang of boys in the troop that you join. The patrol is the unit that makes Scouting go.

In the Scout patrol you will meet boys who may be your friends for the rest of your life. Under one of the Scouts, picked by the gang as patrol leader, you will help in the planning of patrol meetings, hikes and camps, and will do your part in carrying out your decisions.

You will have fun indoors in the patrol den and outdoors under the open sky . . . you will learn the skills of Scouting . . . you will be on the team for Scoutcraft games and contests. You will find out what it means to be a real boy among other real boys—living your life according to the Scout code.





YOU — MEMBER OF A TROOP

Your patrol does not stand alone—it is part of a troop that consists of several patrols that work together. As a member of a troop, you are a member of the Boy Scouts of America as well.

It's fun to take part in a good troop meeting under a capable Scoutmaster—but it is even more fun to go to summer camp with the whole troop, learning new Scoutcraft skills, joining in the excitement of the campfire at night.





7







YOU — PREPARED FOR SERVICE

Scouting is far more than hiking and camping fun. Scouting is learning to grow into responsible manhood, learning to be of service to others.

The Scout Oath and the Scout Law are your guides to citizenship. They tell you what is expected of a Scout and point out your duties. The Scout motto is *Be Prepared*—prepared to take care of yourself and to help people in need. The Scout slogan is *Do a Good Turn Daily*. Together, the motto and slogan spell out your ability and your willingness to be of service.

The records of the Scout movement are full of reports of Scouts who have done outstanding service, of Scouts who have saved the lives of others at the risk of their own. Some day you may join the roster of Scout heroes—if you are prepared.



YOUR UNIFORM

The Boy Scouts of America is the largest uniformed body of volunteers in the world. This very moment, close to 6 million boys and leaders belong to the Boy Scout movement in the United States and wear the Scout uniform with pride.

Your uniform is part of the thrill of being a Scout. The moment you put it on you feel ready for hike or camp or other vigorous Scout activity.

The Scout uniform stands for the brotherhood of Scouting, for the Scout ideals, and for outdoor life. The color blends with the hues of forest and field. The design is made for comfort, for freedom of action, and for health. Every Scout wears the same uniform—it is a badge of democracy, an emblem of service.

To the public, the uniform proclaims aloud, "Here is a boy who is a Scout"—for people know that only a boy who is a full-fledged member of the Boy Scouts of America has the right to wear the Boy Scout uniform.

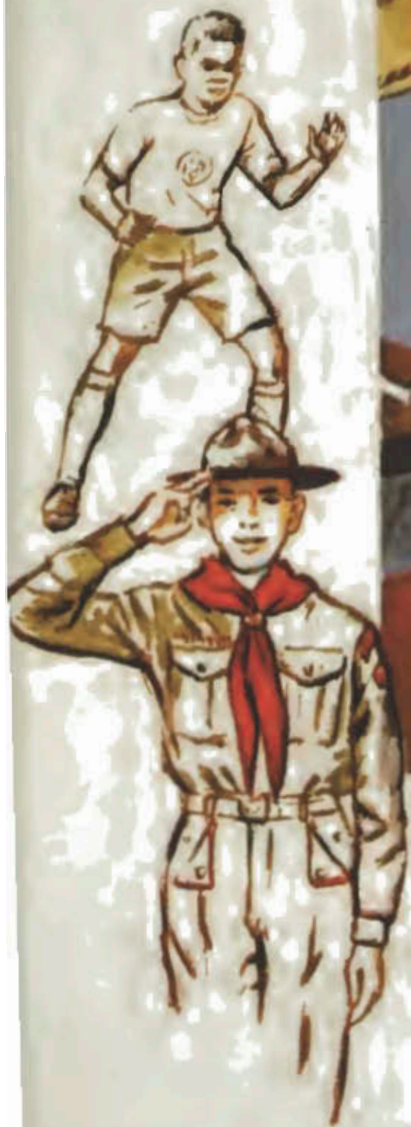



Community strips



Troop numeral



Patrol medallion



Troop librarian



Troop scribe



Junior assistant Scoutmaster



Senior patrol leader



Troop quartermaster



Instructor



Troop bugler



Assistant senior patrol leader



Patrol leader



Assistant patrol leader



Eagle (embroidered)



Eagle palms



Eagle (medal)

Life



Eagle square knot



Star



First Class



Second Class



Tenderfoot



Attendance pin



Service stars

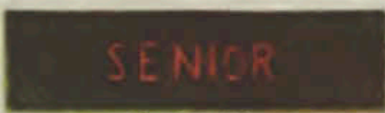

Senior strip



YOUR SCOUT BADGES

On your uniform, you wear the badges that show that you belong, that you are a member of a certain patrol in a certain troop in the Boy Scouts of America.

But there are other badges that tell of the Scoutcraft you have mastered and the rank you have reached and badges that show the world what responsibilities have been entrusted to you by your patrol and your troop.

The badges you earn are the best proof of your determination to make the greatest possible use of the opportunities that Scouting offers you.



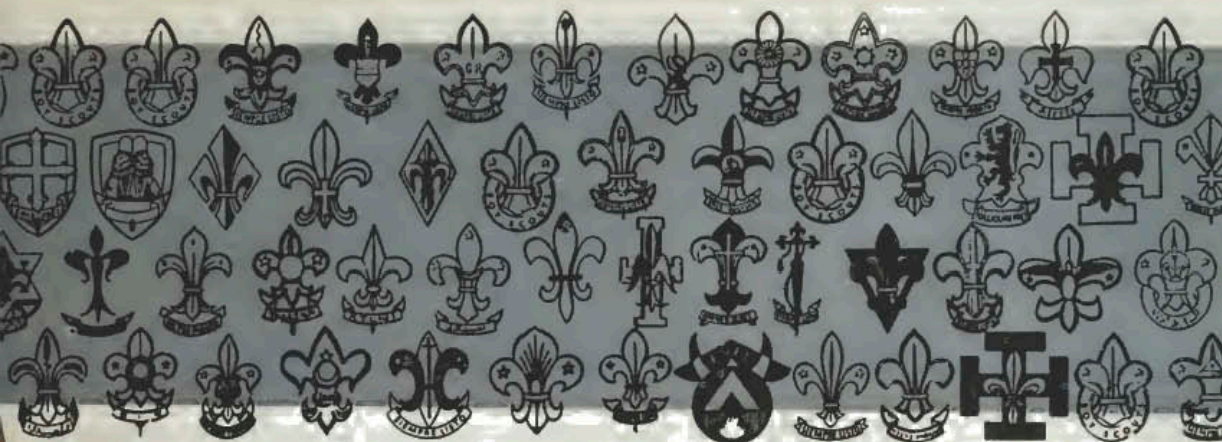

YOU — IN A WORLD BROTHERHOOD



When Lord Baden-Powell—famous English general and a hero to his countrymen—developed the Scouting scheme and founded the Boy Scout movement, he had no idea that it would prove popular enough to spread around the world. But that is what happened.

The day you become a Scout, you join a world brotherhood with close to 9 million members in more than 80 countries around the globe. All these Scouts have pledged themselves to the Scout Oath and Law. All of them consider you their brother.



YOU — ON THE SCOUTING TRAIL

The door to Scouting fun is wide open to you. You will be welcomed in a Boy Scout patrol and troop, and boys already Scouts will help you have a wonderful time in Scouting.

This book will be your guide. The pages printed in red and black tell you how to become a  Tenderfoot Scout. The pages in brown and black lead you on to  Second Class. The pages in green and black guide you to  First Class. The pages in gray and black take you through Star and Life to Eagle Scout rank.

Ready to set out on the Scouting trail? Then LET'S GO! 

26





ADVANCEMENT TRAIL TO EAGLE



FIRST CLASS

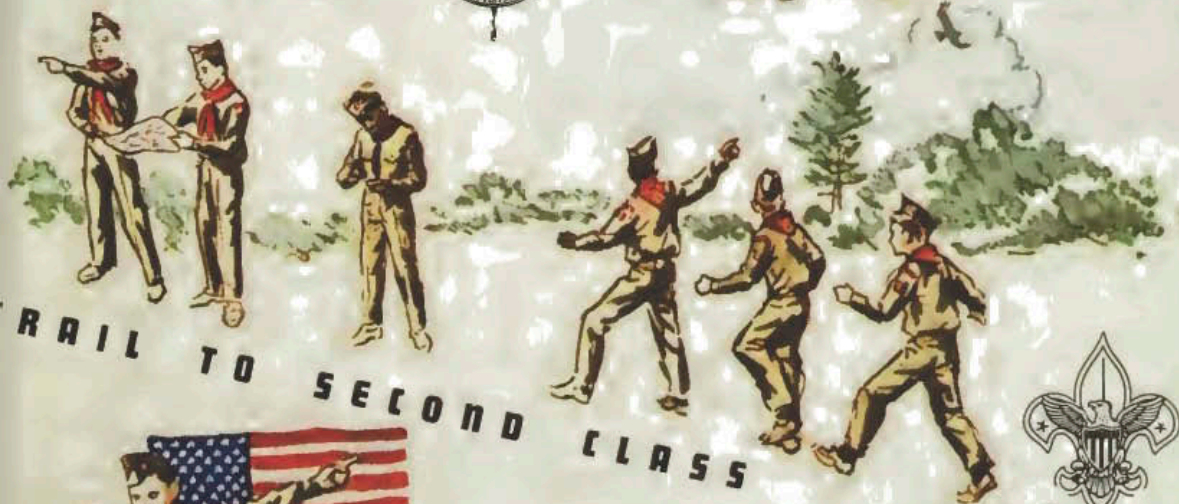

TRAIL TO SECOND CLASS



STARTING TRAIL TO TENDERFOOT



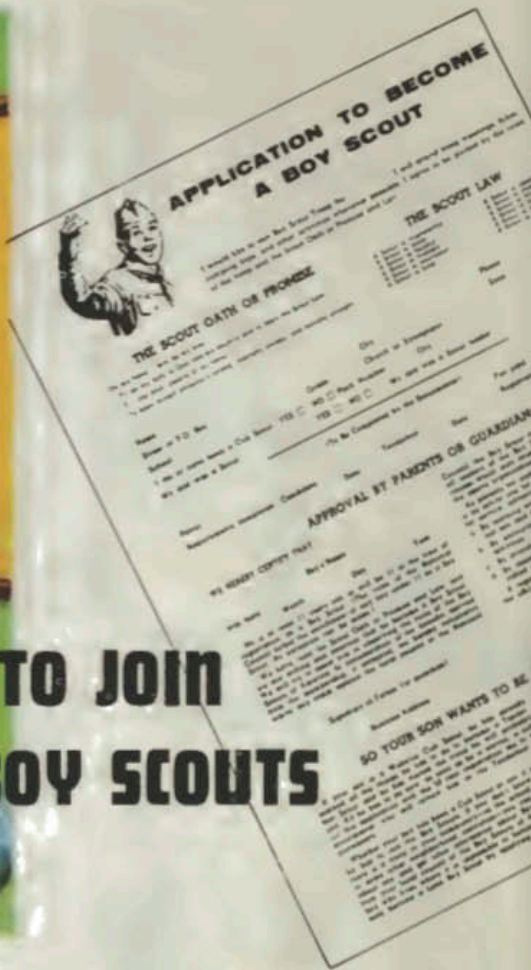
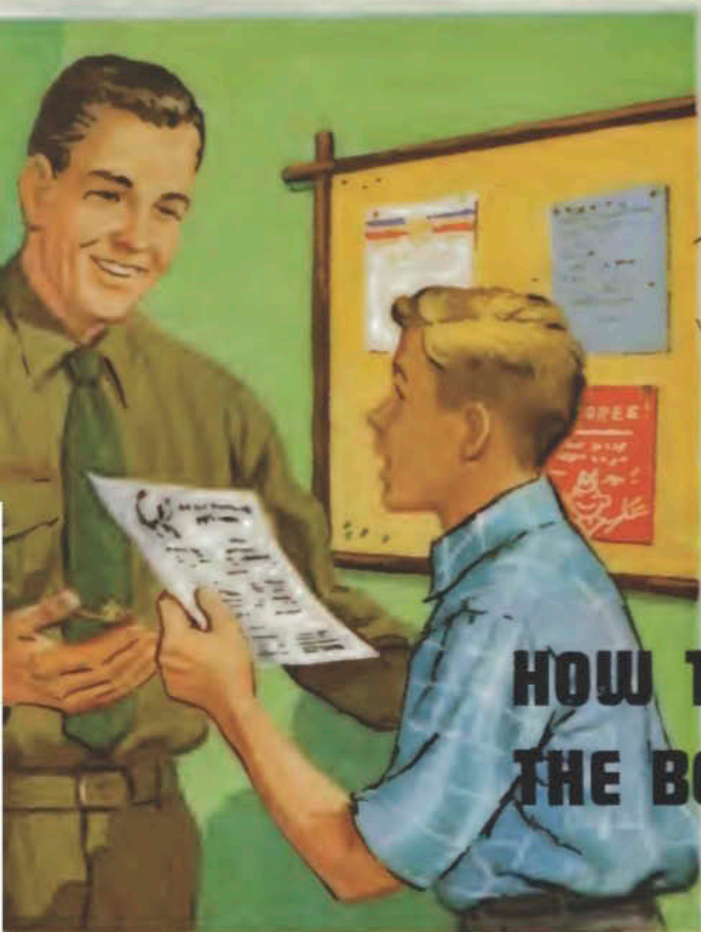

HOW TO JOIN THE BOY SCOUTS

So you want to get in on all the fun and excitement that Scouts have?

Well, there are three things you have to do to become a Boy Scout and enjoy the fellowship of a patrol and a troop.

First, you have to be at least 11 years old.

Second, you have to find a Boy Scout troop near your home.

Third, you have to know the rules of Scouting and the skills expected of a Tenderfoot Scout.

Your Age. There isn't much you can do about your age.

If you are 11 or older, fine! You can be a Boy Scout right away.

If you aren't 11 yet, you'll just have to wait and let nature take its course. But in the meantime, if you are 8 or older, you

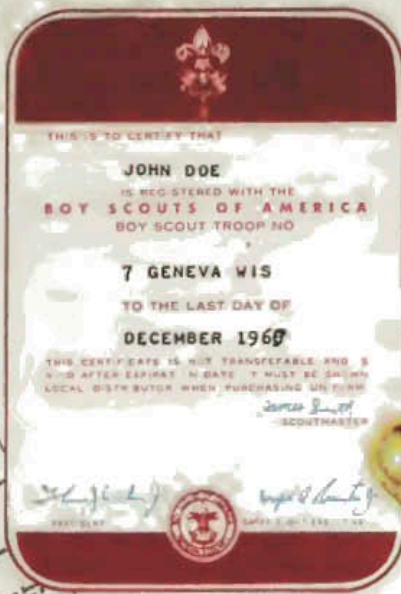

The registration card you receive when you join shows that you are a member of the Boy Scouts of America. Be sure to carry it with you at all times.

can be a member of the younger branch of the Scout movement—Cub Scouting—and have a swell time with other boys of your own age. Then, as you get close to 11, you can train yourself with some of the other Cub Scouts to become a Boy Scout the moment you reach your 11th birthday.

Finding a Troop. You should have no difficulty finding a troop near your home—there are thousands of them scattered across America.

Ask the fellows you know. Some of them are probably Boy Scouts already. When you tell them you want to join, they'll invite you to their next meeting—and you are immediately on your way to becoming a Boy Scout.

Or ask your teacher or religious leader. Very possibly, there's a Boy Scout troop in your school, or in your church or synagogue.

If you live in a large town or city and still haven't found a troop, look in the telephone book under "Boy Scouts of America." Call the number you find, ask about a troop in your vicinity, and get the name and telephone number of the Scoutmaster. Phone

him and ask him when and where the troop meets. Then go to the next meeting and get ready to join. Take your dad along to that first meeting so that he, too, can find out about the troop and can meet the Scoutmaster.

If, by any chance, you live far out in the country where there isn't a Scout troop, that won't prevent you from becoming a Boy Scout. Send a letter to the Boy Scouts of America, National Council, New Brunswick, New Jersey 08903, and explain the situation. They'll tell you how to become a lone Scout or how to form a neighborhood patrol of your own.

Meeting the Tenderfoot Tests. Simply coming to a troop meeting and getting in with your future pals won't make you a Boy Scout overnight. There are rules you must follow and skills you must learn to be a full-fledged Scout. These rules and skills are spelled out in the Tenderfoot tests on pages 34 and 35.

As you read the Tenderfoot tests you will see that some of them deal with the ideals of Scouting—the Scout Oath and Law, the Scout motto and slogan. Others have to do with the outward signs of a Scout—the Scout sign, salute, and handclasp, the Scout uniform and the Scout badge. One Tenderfoot test requires you to know the history of the flag of our country and the respect we owe it. Still others give you a taste of a couple of outdoor skills and tell you of the life that is ahead of you as a Scout.

Study the Tenderfoot tests carefully, then settle down to meet them. You will get plenty of help from the fellows in the patrol you expect to join, especially from your future patrol leader. Your dad can help you, too—he was probably a Scout himself when he was a boy. If you are a Cub Scout, you will learn the tests while you work for your Webelos badge in your Webelos den.

When your patrol leader is confident that you know your stuff, he'll get you a Scout application form. Have your parents fill in this form and sign it. Then sign it yourself and take it to your Scoutmaster with your national membership fee.

Your Scoutmaster will go over the Tenderfoot tests with you to make sure that you know them and understand them. When he is satisfied, he will send your application and your membership fee to the National Council of the Boy Scouts of America through your local council office.

Your Investiture. Now comes the big moment when you are received into Boy Scouting in a simple investiture ceremony.

Some evening at a troop meeting or some night at a campfire, you stand before your Scoutmaster, the Scouts of the troop, and your parents. You raise your right hand in the Scout sign and solemnly dedicate yourself to the Scout Oath:

“On my honor I will do my best to do my duty to God and my country and to obey the Scout Law; to help other people at all times; to keep myself physically strong, mentally awake, and morally straight.”

You pledge allegiance to the flag of the United States of America. From then on you are a member of the world brotherhood of Scouting and are on your way with your patrol and troop toward a life of outdoor fun and adventure, of service to others, of training yourself to become the kind of MAN you want to be.

You dedicate yourself to the Scout Oath at an impressive ceremony before your troop.





**ON THE STARTING TRAIL TO
TENDERFOOT**



MY TENDERFOOT SCORE

- | | | |
|--|------------------------------|-----------|
| <input type="checkbox"/> / 19..... | Scout Oath | 36 |
| <input type="checkbox"/> / 19..... | Scout Law | 38 |
| <input type="checkbox"/> / 19..... | Scout Motto | 52 |
| <input type="checkbox"/> / 19..... | Scout Slogan | 53 |
| <input type="checkbox"/> / 19..... | Scout Sign | 54 |
| <input type="checkbox"/> / 19..... | Scout Salute | 55 |
| <input type="checkbox"/> / 19..... | Scout Handclasp | 55 |
| <input type="checkbox"/> / 19..... | Scout Uniform | 56 |
| <input type="checkbox"/> / 19..... | Scout Badge | 62 |
| <input type="checkbox"/> / 19..... | Our Country's Flag | 65 |
| <input type="checkbox"/> / 19..... | Knots | 74 |
| <input type="checkbox"/> / 19..... | Protect the Outdoors | 83 |
| <input type="checkbox"/> / 19..... | Your Patrol | 88 |
| <input type="checkbox"/> / 19..... | Becoming Second Class | 97 |





T E N D E R F

To become a TENDERFOOT SCOUT, you must be at least 11 years of age and do the following before your Scoutmaster (or an adult assigned by him) :

1. Repeat from memory the Scout Oath (or Promise), the 12 points of the Scout Law, the Scout motto, and the Scout slogan. Explain the meaning of each in your own words.
2. Give the Scout sign, salute, and handclasp. Explain their meaning.
3. (a) Describe the parts of the Scout uniform. (b) Tell when and when not to wear the Scout uniform.
4. Describe the Scout badge and the meaning of each of its parts.
5. (a) Describe the flag of the United States of America and tell its history in brief. (b) Demonstrate respect for your flag by showing how to hoist, lower, display, fold, and salute it. Tell when to fly it.



O T T E S T S

6. Whip the ends of a rope at least one-quarter inch in diameter. Tie correctly two ropes of the same size together with a square knot. Join two ropes of different sizes with a sheet bend. Tie a rope to a rail with a clove hitch. Attach a rope to a post or rail with two half hitches. Tie a bowline around your waist. Tie a taut-line hitch on a rope under tension.
7. Read the Outdoor Code. Tell how you will try to use it in the hiking and camping you will do as a Scout.
8. (a) Explain the name of the patrol you will join and give its call or yell. (b) Discuss the importance of your patrol to your Scout activities.
9. Review briefly the things you will do to become a Second Class Scout.

Give the Scoutmaster your application and fee so he can register you as a Boy Scout. After you have been registered, you take the Scout Oath (or Promise) and the pledge of allegiance to the flag of the United States of America at a ceremony in the presence of your fellow Scouts.



THE SPIRIT OF SCOUTING

Scouting is a game, and like all other games, it has rules you must follow to be a member of the team.

The rules of Scouting are contained in the Scout Oath (or Promise), the Scout Law, the Scout motto, and the Scout slogan.

1 ♣ *Repeat from memory the Scout Oath (or Promise) Explain the meaning . . . in your own words.*

Duties are the foundation of all fair dealings. Every right in the world rests on an equal responsibility. For everything we receive, there are things we must give in return. In the Scout Oath you will find a clear statement of what is expected of you as a Scout—your duty to God and your country, to other people, and to yourself.

DUTY TO GOD AND COUNTRY. Your parents and religious leaders teach you to know and love God, and the ways in which you can serve Him. By following these teachings in your daily life, you do your duty to God as a Scout. Our country was built upon a trust in God. As you look back into the past, you learn about men and



SCOUT OATH OR PROMISE

On my honor I will do my best

**To do my duty to God and my country
and to obey the Scout Law;**

To help other people at all times;

**To keep myself physically strong,
mentally awake, and morally straight.**

women who toiled to make our America, who gave their lives for it when called upon, who raised it to where it is today. It is your duty to carry this work forward by working for your country's welfare, by obeying its laws, by showing your loyalty to its government.

DUTY TO OTHER PEOPLE. There are many people who need a pair of young shoulders to help them with their burdens. A cheery smile and a helpful hand may serve to make life easier for someone who is weak or old, for a woman or a child. By obeying the Scout Law and by doing a Good Turn daily, you prove yourself a Scout and do your part to make this a happier world.

DUTY TO SELF. You owe it to yourself to take care of your body, to protect it and to build it so that it will serve you and make it possible for you to help others. You owe it to yourself to develop the brains that were given you, by striving to increase your knowledge and by making the best possible use of your abilities. You owe it to yourself to aim to become a man of strong character, ready to take your place in the world as a capable citizen.

THE SCOUT LAW

1 ✚ Repeat from memory the . . . 12 points of the Scout Law . . . Explain the meaning of each in your own words.

The Scout Law is the foundation on which the whole Scout movement is built. In the Scout Law are expressed the ideals a Scout puts before himself.

There have always been written and unwritten laws by which men have tried to live.

In the world of today, when you are a Scout, the Scout Law becomes *your* code of action by which you try to live.

There is something about the Scout Law that makes it different from other laws. Most other laws start with a "Do" or a "Don't." Not the Scout Law. The Scout Law is a statement of facts: "A Scout is trustworthy . . . loyal . . . helpful . . . friendly . . . courteous . . . kind . . . obedient . . . cheerful . . . thrifty . . . brave . . . clean . . . reverent." By doing your best to live up to the Scout Law, you are a Scout. If you should *willfully* break the Scout Law, you are not a Scout. It is as simple as that.

The ideals of the Scout Law are high—they are meant to be! It is only by striving toward high ideals and keeping faith with them that you can hope to become the MAN you want to be.



A Scout Is Trustworthy

A Scout's honor is to be trusted. If he were to violate his honor by telling a lie or by cheating or by not doing exactly a given task, when trusted on his honor, he may be directed to hand over his Scout badge.

A Scout Is Loyal

He is loyal to all to whom loyalty is due, his Scout leader, his home and parents and country.

A Scout Is Helpful

He must be prepared at any time to save life, help injured persons, and share the home duties. He must do at least one Good Turn to somebody every day.

A Scout Is Friendly

He is a friend to all and a brother to every other Scout.

A Scout Is Courteous

He is polite to all, especially to women, children, old people, and the weak and helpless. He must not take pay for being helpful or courteous.

A Scout Is Kind

He is a friend to animals. He will not kill nor hurt any living creature needlessly, but will strive to save and protect all harmless life.

A Scout Is Obedient

He obeys his parents, Scoutmaster, patrol leader, and all other duly constituted authorities.

A Scout Is Cheerful

He smiles whenever he can. His obedience to orders is prompt and cheery. He never shirks nor grumbles at hardships.

A Scout Is Thrifty

He does not wantonly destroy property. He works faithfully, wastes nothing, and makes the best use of his opportunities. He saves his money so that he may pay his own way, be generous to those in need, and helpful to worthy objects. He may work for pay, but must not receive tips for courtesies or Good Turns.

A Scout Is Brave

He has the courage to face danger in spite of fear and to stand up for the right against the coaxings of friends or the jeers or threats of enemies, and defeat does not down him.

A Scout Is Clean

He keeps clean in body and thought; stands for clean speech, clean sport, clean habits; and travels with a clean crowd.

A Scout Is Reverent

He is reverent toward God. He is faithful in his religious duties and respects the convictions of others in matters of custom and religion.





A Scout Is Trustworthy

All our dealings with other people are based on trust. We drop a letter in the mailbox and trust the post office to get it to its destination. We buy a can of food and trust the manufacturer to have filled it with only wholesome ingredients. We listen to the news on the radio or on TV and trust the reporters to tell us the truth. We board a bus or a train or a plane and expect it to take us to the place we want to go. If we couldn't trust other people, the work of the world would soon come to a standstill. And if you can't trust a Boy Scout you can't trust anybody.

Your parents and teachers and friends know that as a Scout you tell the truth and keep your promises. When your mother asks you to run an errand, she knows that you will do it promptly and effectively. When your troop has a meeting, your leaders know that you will be there. When you have said that you are going on the hike or to camp, the other fellows in your patrol know that you will be ready to go at the time agreed to.

From time to time, you may get yourself into trouble—boys usually do. Your baseball may smash a window, your elbow may knock down a vase, your big feet may trample a flowerbed. By quickly admitting what you have done and making good the damage, the incident is forgotten.

It is a great thing to have people trust you. It feels good to "keep your honor bright" and to be able to look people straight in the eyes.

A Scout Is Loyal

To be loyal means to be faithful under all circumstances, to stand by, to stick through thick and thin.

Loyalty starts at home. You show this loyalty best by turning yourself into the kind of boy your parents would like you to be, by making them realize that you appreciate what they do for you, and by speaking about your home in such a way that people understand that you love it. You show your loyalty also by helping your parents make it into a happy place for a happy family. The place where you live may not be the finest in the neighborhood—but it is your home, and no palace will ever take its place in your heart.

A chain is as strong as its weakest link. The success of your patrol and your troop depends on the loyalty of each boy—in the way you stick by your leaders and pitch in with the team, in the way you act as a Scout.

People will judge all Boy Scouts by the kind of Scout you are. By being a real Scout, striving to keep the Scout Oath, living up to the Scout Law, you prove yourself loyal to Scouting and to your millions of brother Scouts around the world.

Hundreds of thousands of Americans have shown their loyalty to our country by giving their blood for it. But there are many everyday ways of being loyal, too—by helping in your community projects by showing respect for our flag and our government by obeying our country's laws.



A Scout Is Helpful

In your Scout Oath you pledge to help other people at all times. The third point of the Scout Law tells you how—by being prepared and by doing a Good Turn daily.

A boy who doesn't know first aid is of little use when someone is hurt. A boy who can't swim has little chance to rescue a drowning person. As a Scout you will know what to do—and do it. But while you may never have the chance to save a life, you have a chance every-day to do some smaller service—provided you keep your eyes open.

Your regular home duties are not Good Turns—those are things that are expected of you. A Good Turn is something you go out of your way to do. One kind of Good Turn is the kind you do on the spur of the moment—like assisting a blind man to get on a bus, picking up broken glass from the sidewalk, helping a motorist change a tire. Another kind of Good Turn is the kind you plan for alone or with your patrol—like feeding birds during the winter, taking used magazines to the hospital, cleaning up the church or synagogue basement.

It is not the size of the help that counts but the spirit in which it is rendered.

The important thing to remember about Good Turns is that they are done for the sake of helping others. Work (for which you receive pay) and help you give to one who needs it (for which you receive no pay) are two different things. A Good Turn done in the hope of receiving a tip is not a Good Turn at all.



A Scout Is Friendly

Friendship is like a mirror. When you meet a person with a smile on your face and a helping hand stretched toward him, you will receive a smile in return and help when you need it. By being a friend yourself, you make a friend.

But there are friends and friends. Some people to whom you show friendliness will pass out of your life immediately afterward. Others may become your friends for life. That kind of friendship you only give to very few. It is sincere and fine and cannot be divided among many.

It is very possible that you will form some of your own lifelong friendships through Scouting.

The moment you join a patrol and a troop you enter a brotherhood that spans the world. The boys in it are of different countries and colors and creeds, but they are brothers together, living up to the same Scout Oath and Law that you are following.

Among the finest expressions of this brotherhood are the great world jamborees at which as many as 50,000 Scouts from all over the world come together and live in camp for 2 weeks as friends.

But you need not go to a jamboree to show that you are "a brother to every other Scout." When you meet a fellow Scout in uniform, greet him as a friend. He may be a stranger in your town. By greeting him in this way, you make him feel that he is not alone. You can make him feel at home.



A Scout Is Courteous

This is just another way of saying that a Scout is a gentleman. You will have many opportunities everyday to show whether you are one or not.

First of all, be courteous in your own home. There are people with the reputation of being polite in public who seem to forget their manners when at home. Don't be one of them. A "please" and a "thank you" are easily said, and little helpful things easily done, yet they make your father and your mother and the other members of the family feel that you really appreciate what they do for you.

Good manners always please and attract people. Opening a door for a lady, offering a seat in a crowded bus, rising from your chair when a guest enters the room, helping your mother to be seated at the family table, saluting your Scout leader, removing your hat in the presence of ladies in an elevator—these are all signs of a gentleman.

A story is told of an old man who went to see one of the Olympic games in ancient Greece many years ago. He was late. There was not a single seat available. A Spartan youth noticed the old man's plight. He beckoned him near and gave him his seat. A group of young Athenians who had witnessed the incident began to applaud. The old man turned toward them and said. "Yes, you young Athenians know what it is right to do—but it takes a Spartan to do it."

The courtesy you practice as a youth will make you a finer man.



A Scout Is Kind

If you have a dog or other animal pet of your own you are probably already kind to it. You want it to love you and you know that this will happen only if you take good care of it. You have to understand when it needs food and water and shelter and special attention. If you live on a farm you know how well poultry and livestock respond to good care.

In your life as a Scout, you will get to know a lot of wild animals. Some evening when you are on a hike, a deer may bound across your path. Some night in camp, a raccoon may come sniffing around your tent. And when you wake in the morning and put your head outside your tent door, you may hear the chorus of a hundred birds and see them fluttering from branch to branch overhead.

The more you live in the out-of-doors, the more you will get to like the animal and bird life around you. And the more you like wildlife, the more you will do to help it and to protect it.

But you will also learn that there are creatures that do not deserve your protection.

A Scout does not kill any living thing needlessly, but he knows that it is his duty to help get rid of those that are dangerous to human beings. He doesn't hesitate to kill animals such as rats or insects such as flies and mosquitoes that carry sicknesses along with them nor to destroy poisonous reptiles that may endanger human life.



A Scout Is Obedient

A distinguished French officer once asked the mother of George Washington, "How did you raise such a splendid son?" Her answer was simple. "I taught him to obey."

This is true of all great leaders. They learned to obey before they learned to lead. That's why real men hold obedience high.

Obedience begins with your father and mother. When they request you to do a thing, do it immediately and cheerfully—even if you happen to be in the middle of a game or an exciting TV program. Soldiers do not enjoy going into battle. But they obey orders. They know what is expected of them and do it.

There are others to whom you owe obedience. When a teacher tells you to do a thing, it is usually for your own good. When your employer tells you to do a thing, it is for the good of the business. And when your Scout leader gives you a job to do, it is for the good of the patrol or troop—which means it is good for you, too.

But being obedient goes beyond the obedience you owe to certain individuals. It also means obedience to your country's laws. Here again, obedience works to your own good. Think, for instance, of all the lives that would be saved each year if people obeyed the traffic laws. And just imagine the amount of money that would be available for education and other worthwhile purposes if people were so law-abiding that we could close all our prisons.



A Scout Is Cheerful

There's an old saying that goes, "Smile and the world smiles with you—weep and you weep alone."

There are people who always see the dark side of things. They are dissatisfied when the sun shines—it hurts their eyes and it is too hot. They are annoyed when the sun doesn't shine—things are too cold and dark. If it rains it is bad, and if it doesn't rain it is still worse.

Then there are others who are happy always. When the sun shines they enjoy the bright weather. When it pours they say, "Just what the farmers needed!" People who are cheerful and satisfied not only make life easier for themselves, but they help their fellow beings too.

It is not the good times you have that will make you the man you want to be. It is when things turn against you that you can best prove that your cheerful disposition has its root in the courage of your soul. It is as you learn to overcome difficulties with a smile that you will grow to be a real man.

In Scouting, you will have a lot of fun on sunny days. But peculiarly enough, the memories that will live the longest in your heart will be of the times when you overcome obstacles cheerfully—when the patrol fights its way home from a hike against a stiff wind and every step seems to be a mile, when a drenching downpour puts out your campfire, when your tent blows down in the middle of the night. These are the times when your cheerfulness is tested and your manliness grows.



A Scout Is Thrifty

To be thrifty doesn't necessarily mean to save money. Far oftener it means to know how to spend money wisely and to take good care of things that represent money—your clothes, your books, your home, and your school.

As a matter of fact, real thrift consists of five different things: earning, saving, spending wisely, sharing, and conserving.

It is a wonderful thing to be able to pay your own way—to earn money for your own clothes, for your Scout uniform and your camp equipment, and to take care of your troop dues out of your own pocket. Your savings could go into a savings bank or into United States savings stamps or bonds.

It takes determination to earn money and save it. Some fellows never succeed. They go after easy money and it always slips away from them. They sometimes even leave school without graduating because they see a job that will give them quick money—without realizing that the fellow who completes his education will earn far more in the end.

It is a good thing to be able to put money in the bank; but, while you are young, it is more important for you to spend it on a good education, and to learn to share what you earn with others who may be in greater need.

It is not only in your everyday life that you prove your thrift. You prove it also by the way you protect and conserve our country's natural resources whenever you go hiking and camping.



A Scout Is Brave

The highest award a Scout can receive is the Honor Medal for lifesaving. This is not earned by just rescuing someone—it is given only if the deed required real heroism and was done at the risk of the Scout's own life. In spite of these high standards, more than 1,300 Scouts have earned the Honor Medal since the founding of the Boy Scouts of America. Those boys had a glorious opportunity to prove their bravery and were prepared to act.

Your opportunity may come.

Will you be ready for it?

But lifesaving is not the only way you can prove your bravery. You can show it in your everyday life.

It takes bravery to stand up for what you think is right when others try to make you do what you know is wrong. It sometimes takes real courage to speak the truth and nothing but the truth. It takes backbone to admit a mistake and to apologize for it. It takes backbone to defend a friend when he is under attack by others.

During the Revolutionary War, young Nathan Hale secretly entered the British encampment at New York to find out what forces were there. He was caught and was hanged as a spy. His last words were, "I only regret that I have but one life to lose for my country."

Countless other Americans have been willing to lay down their lives for what they thought right. Certainly you will be brave enough to stand up for *your* convictions.



A Scout Is Clean

Two boys were walking along a muddy road when one asked the other, "How do you keep your shoes so clean? Mine are getting all dirty." The other boy answered, "That's easy—I just look for the clean spots and put my feet there."

The simplest way of being clean is not to get dirty in the first place. And that goes not just for your clothes and your body, but also for your thoughts and words and deeds.

You never need to be ashamed of the dirt that will wash off. If you play hard and work hard, you can't help getting dirty. But when the game is over or the work done, that kind of dirt gives way to soap and water.

But there is another kind of dirt that won't come off by washing. It sticks. It is the kind that goes below the skin, that sinks into your mind. A boy has a hard struggle fighting that kind of dirt, keeping his thoughts clean. But if you really try, you will win. By forcing your mind to occupy itself with things that are good and true you will be able to overcome temptations and will be at peace with yourself.

An important part of the battle is to keep away from fellows who seem to get a kick out of using vile language and telling dirty stories. "If you play with tar," as the saying goes, "some of it is sure to stick."

Get in with a clean crowd where you will hear clean speech, learn clean sportsmanship, and get a clean outlook.



A Scout Is Reverent

Take a Lincoln penny out of your pocket and look at it. What do you see on it? Just above Lincoln's head are the words "In God we trust." Twelve little letters on our humblest coin. Not only as individuals, but as a nation, too, we are committed to live and work in harmony with God and with His plan.

Most great men in history have been men of deep religious faith who have shown their convictions in deeds. Washington knelt in the snow to pray at Valley Forge. Lincoln always sought divine guidance before making an important decision. Eisenhower prayed to God before taking his oath of office as President of the United States. Kennedy asked God's blessing and help and challenged all Americans—young and old—to remember "that here on earth God's work must truly be our own." These men had many things in common: love of the out-of-doors, human kindness, and an earnest vigor in working with God in helping make a better world.

You are reverent as you serve God in your everyday actions and are faithful in your religious obligations as taught you by your parents and spiritual leaders.

All your life you will be associated with people of different faiths. In America we believe in religious freedom. That is why we respect others whose religion may differ from ours, although for reason of conscience we do not agree with them. Their customs may be different from ours, but their hearts are just as true, their faith just as sincere.





THE SCOUT MOTTO

1  Repeat . . . the Scout motto . . . Explain the meaning . . . in your own words.

The Scout motto is BE PREPARED. Someone once asked Baden-Powell, the founder of Scouting, "Be prepared for what?" "Why," said B-P, "for any old thing." That's just the idea. The Scout motto means that you are always in a state of readiness in mind and body to do your duty and to face danger, if necessary, to help others.

Some time ago, a school bus skidded in a sleet storm in one of our northern states and overturned. The driver was seriously hurt, but a young boy quickly took command. He immediately turned off the motor, got the emergency door opened, helped get the frightened children out, then bandaged up the driver. Help arrived soon afterward, and one of the helpers asked the boy, "How did you manage to do what you did?" "Well," said the boy, "the first time I traveled on that bus, I asked myself, 'What'll you do if we ever have an accident?' I looked around, noticed how the driver operated the motor, read the instructions for opening the emergency door. And then I used my Boy Scout first aid training."

That boy knew what was meant by being prepared: He thought out in advance what might have to be done in case of an accident. He was trained for any emergency that might occur. He acted and did his duty because he was confident of his ability.



DO A GOOD TURN DAILY

THE SCOUT SLOGAN

1  Repeat . . . the Scout slogan . . . Explain the meaning . . . in your own words.

The Scout slogan is DO A GOOD TURN DAILY. This does not mean that you are supposed to do *one* Good Turn during the day and then stop. On the contrary—it means for you to do *at least* one Good Turn a day. It means looking for opportunities to help and then helping, quietly and without boasting.

Some Good Turns are big things—saving a human life at the risk of losing your own . . . rescue work in floods . . . service in hurricane-stricken areas . . . helping to fight a forest fire . . . working with your patrol on a conservation project . . . giving younger boys a good time in Cub Scouting by working as a den chief.

But Good Turns more often are small things, thoughtful things—helping a child cross the street . . . clearing trash off the highway . . . picking up broken glass from the street . . . telephoning the power company to report a live wire.

Remember always that a Good Turn is an *extra* act of kindness—not just something you do because it is good manners.

To answer the inquiry of a passerby about an address is not a Good Turn—that is common courtesy.

But to go out of your way to take the traveler to his destination—that's a Good Turn.



SCOUT SIGN

SCOUT SALUTE

OUTWARD SIGNS OF A SCOUT

When you have become a member of the Boy Scouts of America, you show that you belong by using the Scout sign, salute, and handclasp, and by wearing the official uniform and the Scout badge.

2  Give the Scout sign, salute, and handclasp. Explain their meaning.

THE SCOUT SIGN

The Scout sign identifies you as a Scout anywhere in the world. You use it when you give the Scout Oath and Law. When another boy greets you with the Scout sign, you know that he is a member of the world brotherhood of Scouting—you respond by making the Scout sign. Raise your right hand palm forward, with the three middle fingers upward and the thumb covering the nail of the little finger, upper arm straight out to the side, forearm straight up. The three upstretched fingers in the Scout sign—as well as the three fingers held together in the Scout salute and the Scout handclasp—stand for the three parts of the Scout Oath; the thumb and little finger stand for the bond that ties all Scouts together.



SCOUT HANDCLASP

THE SCOUT SALUTE

The Scout salute signifies respect and courtesy. You use it to salute the flag of the United States of America. You give it when you approach a Scout leader and again as you leave him.

To give the Scout salute, place the fingers of your right hand in position as for the Scout sign. Bring the hand smartly up to your head, palm sideways, until your forefinger touches the edge of your cap above the right eye or, if you are capless, your forehead above the right eye. When the salute is completed, snap your hand down quickly to your side.

THE SCOUT HANDCLASP

The Scout handclasp is a token of friendship. That is why it is made with the left hand—the hand nearest to the heart, the hand of friendship.

To give the Scout handclasp, extend your left hand with the three fingers outstretched, the little finger and the thumb spread out. Interlock your fingers with your friend's fingers and clasp his hand firmly.



THE SCOUT UNIFORM

Your uniform is part of the thrill of being a Scout. Put on your uniform and immediately you feel ready for hiking or camping or any of the other vigorous Scouting activities.

It is not absolutely necessary to wear a uniform to prove yourself a Scout. The important point is that you live Scouting in your daily life. And yet, the uniform helps you be a *better* Scout. Dressed as a Scout you want to *act* like one. Besides, a uniform makes Scouting easier for you, because it is comfortable and can stand all kinds of hard use.

What the Uniform Stands For. To many a boy, putting on the Scout uniform for the first time is one of the greatest thrills of his



life. And no wonder, when you think of the significance of that khaki uniform.

First of all, it shows that you *belong*—that you are a member of the largest youth movement the world has ever seen, that more than 9 million boys throughout the world consider you their friend and brother. It represents the spirit of true democracy, bridging the differences between rich and poor, putting all on an equal basis in the feeling of real brotherhood. It also helps build that all-desirable thing—gang spirit—in your patrol and your troop.

But not only that—the uniform is a steady reminder that you have pledged yourself to the same high ideals of living as have your brother Scouts and that dressed as a Scout, you must act as a Scout. It challenges you to do those things that stamp you in the eyes of the world as a real Scout and it keeps reminding you that you have promised *to do your best*.

And finally, the color and design of the cap, the shirt, the shorts or trousers, the stockings, the shoes make the uniform the clothing of the outdoorsman. The khaki color blends with the hues of the forest, making you almost invisible when you track animals or study birds. The design is made for comfort, for great freedom of action, and for health.

Thus, the uniform stands for *brotherhood, Scout ideals, and outdoor life*. That's why you want to wear it correctly.

The Parts of the Uniform

3a  Describe the parts of the Scout uniform.

The Boy Scout uniform consists of cap or hat, shirt, trousers or shorts, belt, and stockings—all khaki-colored. In cold weather, the long-sleeved shirt and trousers are in order. When the weather is hot, the favorite uniform for hiking and camping is the short-sleeved shirt, shorts, and long stockings.

The triangular neckerchief is the most distinguishing feature of the Scout uniform. Its color tells what troop you belong to. You hold it in place with a slide.

Boy Scout shoes—brown or black—are made of soft leather and have sturdy soles.

How To Get the Uniform. Only Boy Scouts in good standing—boys who have passed the Tenderfoot tests and are registered with the Boy Scouts of America—have the right to wear the official Boy Scout uniform.

The moment you have been accepted into the troop, you'll want to get a uniform. Ask your Scoutmaster what local dealer is the official Scout distributor. When you have received your Boy Scout registration card, take it with you to the store and get your uniform and the badges you are entitled to wear: community strip, troop numeral, patrol medallion.

Wearing the Uniform

3b ✚ *Tell when and when not to wear the Scout uniform.*

WEAR THE UNIFORM: At all activities of your patrol and troop—meetings, hikes, camps, rallies. When you appear for advancement before a board of review or court of honor. When you take part in a special Scout service for your community. Throughout Boy Scout Week in February.

DO NOT WEAR THE UNIFORM: When you collect funds or take part in a selling campaign. (This does not forbid Scouts in uniform from selling tickets for Scout circuses, rallies, and similar Scouting events, or selling items related to such events.) When you participate in a distinctly political activity. When you appear on the stage professionally (except by special permission).

Care of the Uniform. As a Scout, you are careful of your clothes at all times—your uniform as well as your civilian wear. Fold your uniform carefully after use or hang it on hangers.

Keep your uniform clean and in good repair. Remove spots as soon as possible. If you like, have it dry-cleaned. Otherwise, wash in lukewarm water with a mild soap or detergent and hang up to dry. Pull gently into shape and iron while still slightly damp.

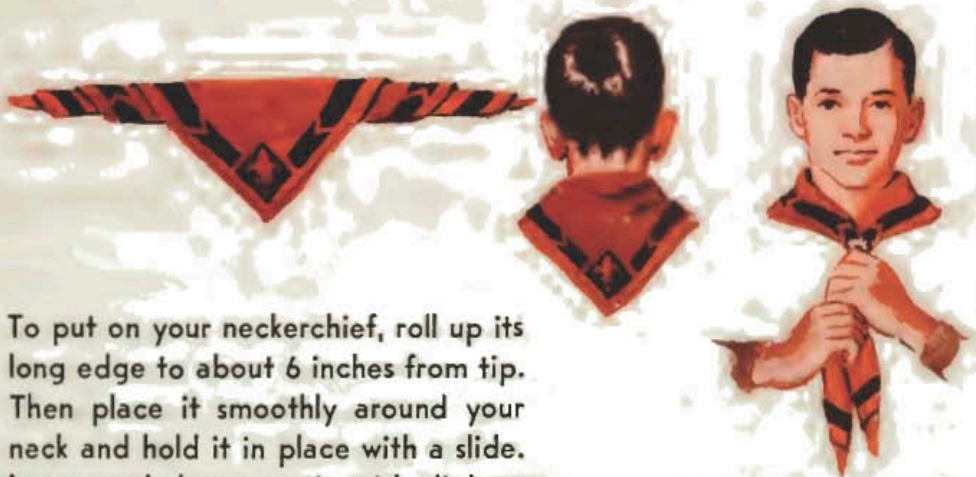

To put on your neckerchief, roll up its long edge to about 6 inches from tip. Then place it smoothly around your neck and hold it in place with a slide. Leave ends loose or tie with slipknot depending on troop custom. Turn the collar of a long-sleeved shirt under.

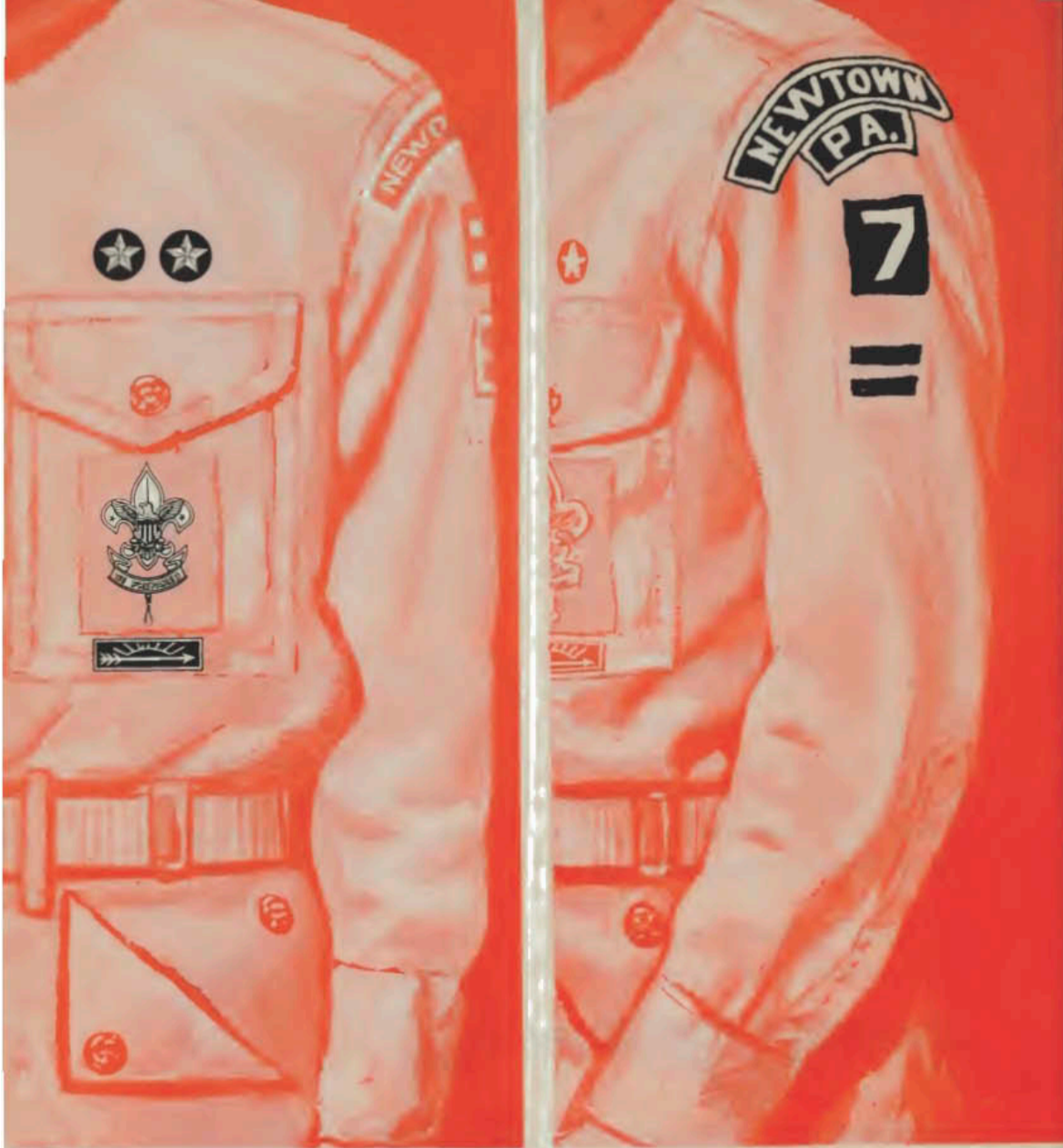

Left Pocket—The embroidered badge of rank is centered on the left pocket. Metal Eagle badge is pinned directly above edge of flap. The service stars that tell your years as a Scout are $\frac{3}{8}$ inch above flap. Webelos badge is centered immediately above lower seam of pocket.

Left Sleeve—Community strip is sewn on in such a way that the top edge touches the shoulder seam. Troop numeral is 2 inches below seam, badge of office 4 inches below seam. Bottom of sleeve is clear.

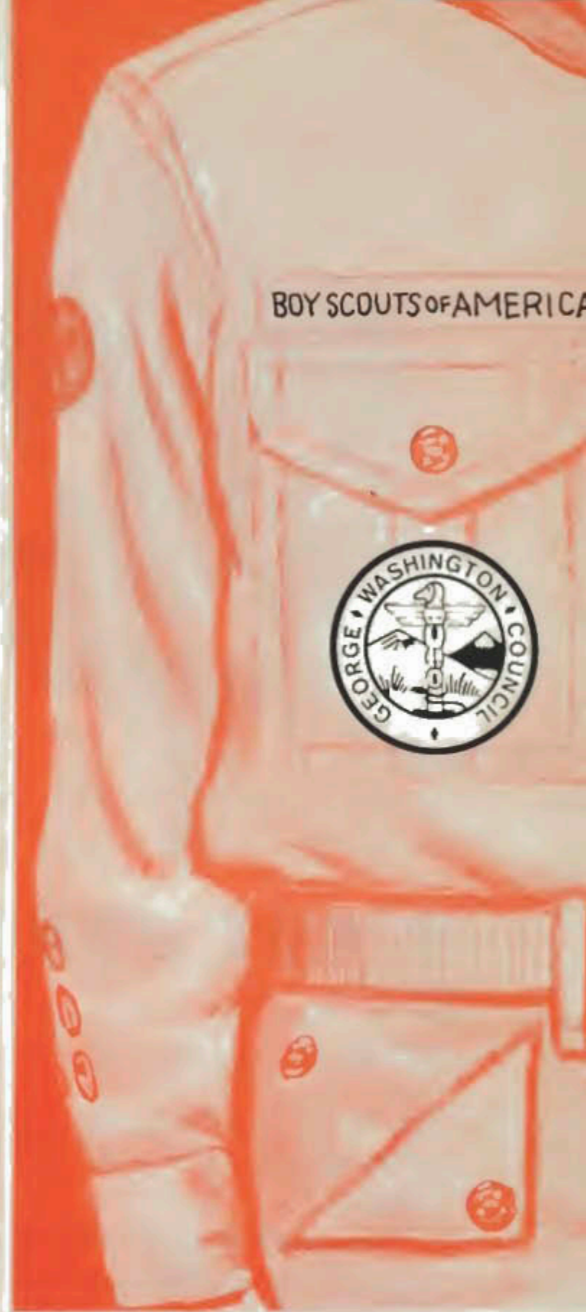

Right Sleeve—Your patrol medallion goes on the right sleeve, 2 inches below the shoulder seam. At bottom of sleeve, starting 3 inches above edge, you may wear up to six merit badges. If you have more than six, sew them on a sash; wear the sash over your right shoulder.

Right Pocket—Centered on the right pocket you sew any temporary badge you are entitled to wear—such as a summer camp badge. The embroidered "Boy Scouts of America" strip is above the right pocket.



The main part of the Scout badge signifies that a Scout is able to point the right way in life as truly as the compass points it in the field.

SCOUT BADGE

4  Describe the Scout badge and the meaning of each of its parts.

The Scout badge was adapted from the north point of the old mariner's compass.

The design is often referred to as a *fleur-de-lis* (lily flower or iris flower), but it goes so far back in history that it is uncertain whether originally it was meant to represent a flower or an arrowhead.

With slight changes, the trefoil Scout badge is used in countries around the world as a mark of the Scout brotherhood of friendliness and good citizenship.



The eagle with the shield is the national emblem of the United States of America. It stands for freedom and readiness to defend that freedom.



The three points, like the three fingers in the Scout sign, stand for the three parts of the Scout Oath to which a boy pledges himself as a Scout.

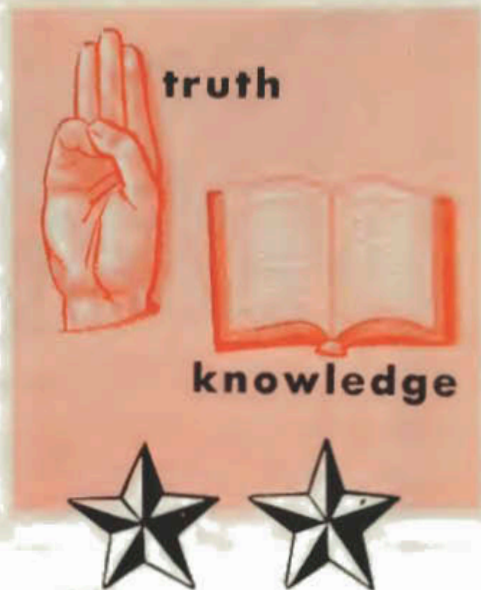

The stars symbolize the ideals of truth and knowledge of the Scout movement. They guide you by night and suggest a Scout's outdoor life.



The scroll with the Scout motto is turned up at the ends to suggest the corners of a Scout's mouth raised in a smile as he does his duty.



The knot attached to the bottom of the scroll is to remind you that, as a Scout, you have promised to do a Good Turn to someone else every day.



OUR COUNTRY'S FLAG

The flag ceremony is about to start. All the patrols are in line. A signal. "Salute!" And the honor guard hoists the flag of the United States to the peak. With your friends to the right and to the left, you pledge your allegiance to your flag and to your country. And as you look at that flag and think of the pledge you are making, you feel again the thrill of being an American.

That flag is far more than the red, white, and blue cloth of which it is made. It is the symbol of our America. It stands for the past and the present and the future of our country. It stands for our people, our land, and our way of life.

When the Thirteen Original Colonies set out to become a free country close to 200 years ago, their men and women needed a rallying point, a flag.

"We will take the stars and blue union from heaven," the great Washington is reported to have said, "red from our mother country, separating it by white stripes, thus showing that we have separated from her, and the white stripes shall go down to posterity representing liberty."

The Pledge of Allegiance to the Flag of the United States of America

I pledge allegiance to the flag of the United States of America and to the Republic for which it stands, one Nation under God, indivisible, with liberty and justice for all.

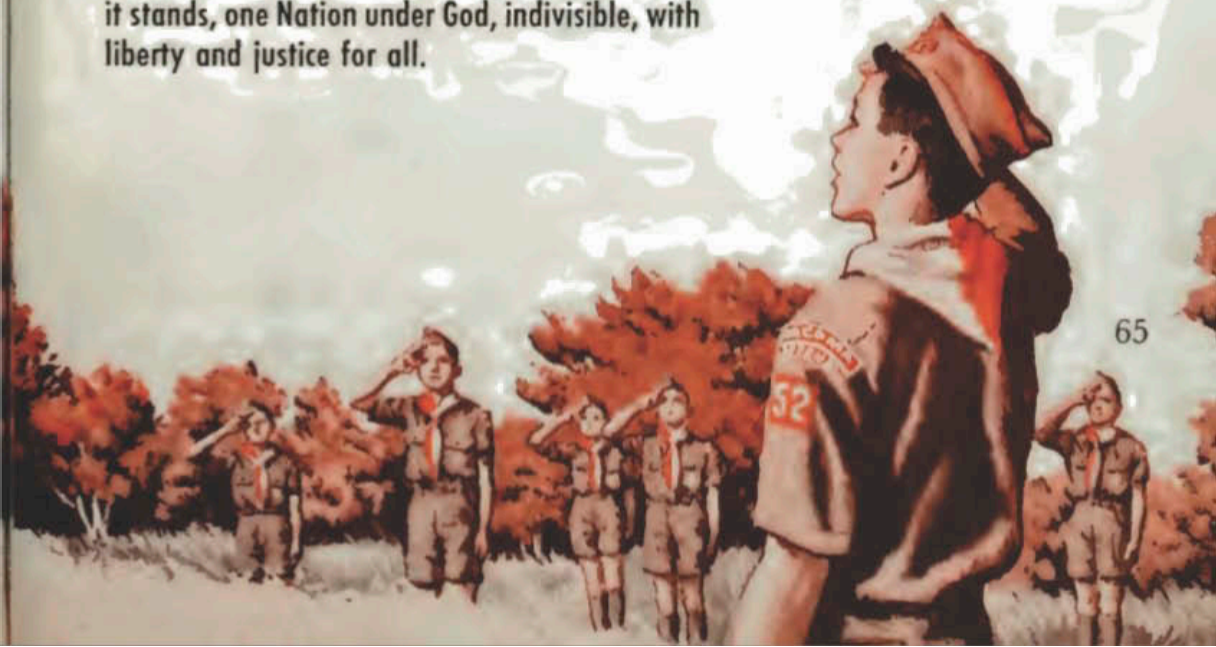

During the Revolutionary War, men and women fought under that flag to gain their liberty. Since then, others have fought to keep that liberty. And whenever victory was theirs, they greeted their flag, their throats choked, and their eyes filled with tears of joy.

Possibly no one has better described this emotion than a young American lawyer who watched the bombardment of the American Fort McHenry outside of Baltimore, Maryland, by a British fleet on a September night in 1814. His heart was full of concern for his countrymen, and as morning came, he gazed toward the fort and wondered:

*"O say can you see, by the dawn's early light,
What so proudly we hailed at the twilight's last gleaming,
Whose broad stripes and bright stars through the perilous fight,
O'er the ramparts we watched, were so gallantly streaming?
And the rocket's red glare, the bombs bursting in air,
Gave proof through the night that our flag was still there,
O say does that star-spangled banner yet wave
O'er the land of the free and the home of the brave?"*

The bombardment ended at 8 a.m., September 14, 1814. As the smoke cleared, the young man saw that the flag was still flying



over the fort. In his joy, he found expression for his hope for the future of his country:

*“O thus be it ever when freemen shall stand
Between their loved homes and the war’s desolation!
Blest with vict’ry and peace may the heaven rescued land
Praise the Power that hath made and preserved us a nation!
Then conquer we must, when our cause it is just,
And this be our motto—‘In God is our trust.’
And the star-spangled banner in triumph shall wave
O’er the land of the free and the home of the brave.”*

That day, the young man wrote down what he had felt, a friend had his poem printed, and shortly afterward his words were sung throughout the country. Francis Scott Key had written the song that became our national anthem.

Whenever you hear it played or sung, stand up, salute if you are in uniform, or place your right hand over your heart if you are in civilian clothes—and think of your own future under that Star-Spangled Banner.

The History of Our Flag

5a  Describe the flag of the United States of America and tell its history in brief.

The flag of the United States of America of today has 13 stripes—7 red and 6 white—and 50 white stars on a blue field: five rows of 6, four rows of 5. The stripes remind us of the Thirteen Original Colonies that gained us our liberty, the stars represent the States that are bound together into one country.

The flag you help hoist at home or over your troop camp grew out of many earlier flags raised in other days over American soil.

The Queen Anne flag waved over the Thirteen American Colonies from 1707 to the Revolution. This was the merchant flag of England—red with a union combining the crosses of St. George and St. Andrew. Before this, other flags had flown over different parts of America—the banner of the Norsemen; the flags of Spain, France, Holland, Sweden; and an earlier English flag.

The Grand Union flag was raised over George Washington’s



QUEEN ANNE FLAG was red with a blue union with the two crosses of St. George and St. Andrew.



In the GRAND UNION FLAG, 6 white stripes broke the red field into 7 red stripes—making 13 in all.



OLD GLORY had 13 stripes and a blue field with 13 stars representing a new and imaginary constellation.



The STAR-SPANGLED BANNER of our national anthem had 15 stripes in it with 15 stars in a blue field.



In 1818, the number of stripes was reduced to 13, and a star was put in the field for each of the 20 States.



headquarters outside of Boston on January 1, 1776. The Revolutionary War had started the year before, and the Colonies needed a flag of their own. The union was the same as that of the Queen Anne flag, but the red field was broken into 7 red stripes by 6 white ones.

Old Glory was the first official flag of the new nation, the United States of America. It was created by a resolution of the Continental Congress in Philadelphia—that the flag of the 13 United States be 13 stripes alternate red and white; that the union be 13 stars, white in the blue field, representing a new constellation. The resolution was passed on June 14, 1777—a date we celebrate every year as Flag Day.

The Star-Spangled Banner that waved over Fort McHenry when it was bombarded, September 13-14, 1814, and inspired Francis Scott Key to write our national anthem had 15 stripes and 15 stars. Two stripes and two stars had been added to the original 13 on May 1, 1795.

When still more States joined the United States, it was soon found that the flag would get to be an awkward shape if more and still more stripes were added. Therefore, on April 4, 1818, Congress passed a law that restored the design to the original 13 stripes and provided that a star be added to the blue field for each new State.

Respect to Our Flag

5b  *Demonstrate respect for your flag by showing how to hoist, lower, display, fold, and salute it. Tell when to fly it.*

When To Fly the Flag. The flag of the United States should be flown every day when weather permits, especially on New Year's Day, Inauguration Day, Lincoln's Birthday, Washington's Birth-

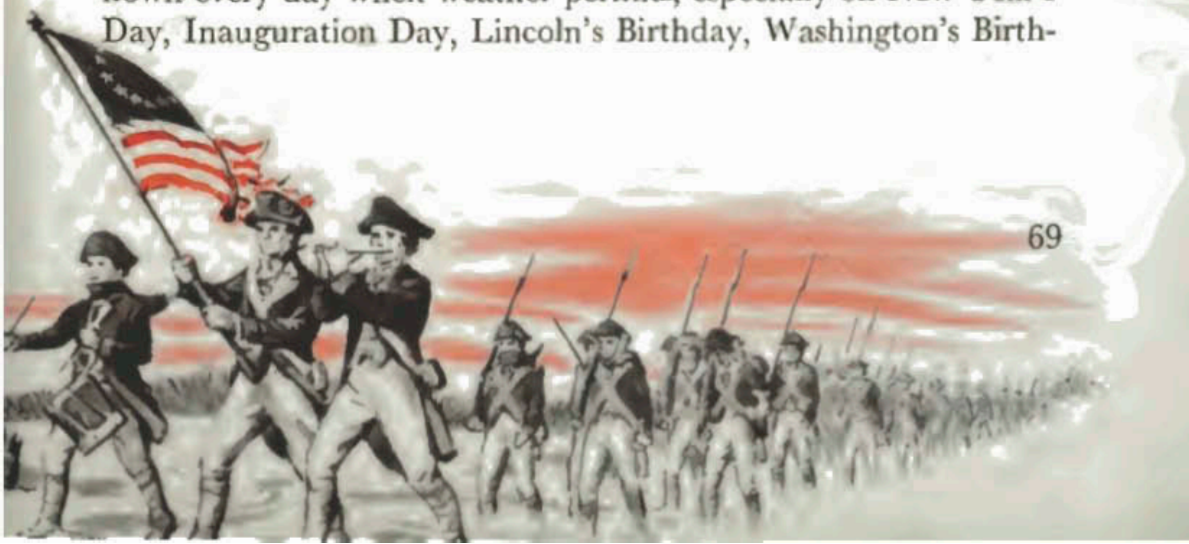

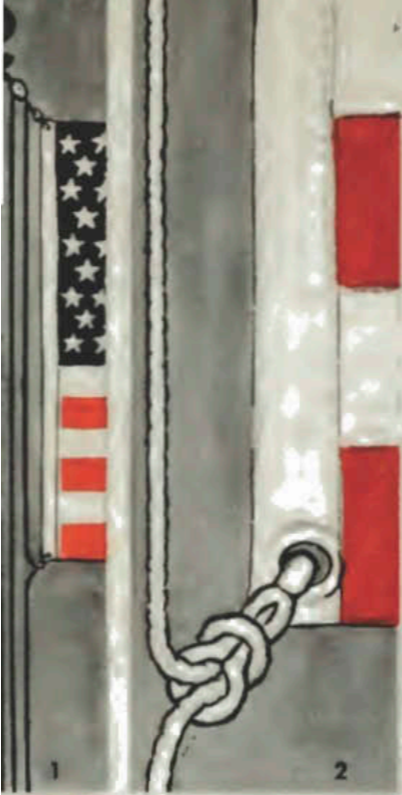

day, Armed Forces Day, Easter Sunday, Mother's Day, Memorial Day (half-staff until noon, full-staff to sunset), Flag Day, Independence Day, Labor Day, Citizenship Day, Columbus Day, Veterans Day, Thanksgiving Day, Christmas Day; the birthday of states (dates of admission), state holidays.

Hoisting and Lowering Our Flag.

Joy is indicated by flying the flag at full-staff (1). You hoist it briskly in the morning, but not earlier than sunrise. You lower it slowly in the evening, but not later than sunset.

Mourning is indicated by flying the flag at half-staff. You hoist it to the peak first, then lower it to half-staff. When ready to take it down, you raise it to the peak, then lower it.

It takes two people to hoist or lower the flag correctly. Take turns at the tasks involved.

In *hoisting*, you hold the flag to prevent it from touching the ground. The other Scout attaches the flag to the line, preferably with snap fasteners (2). He then raises it quickly, keeping it close to the pole by holding the line rather taut (3).

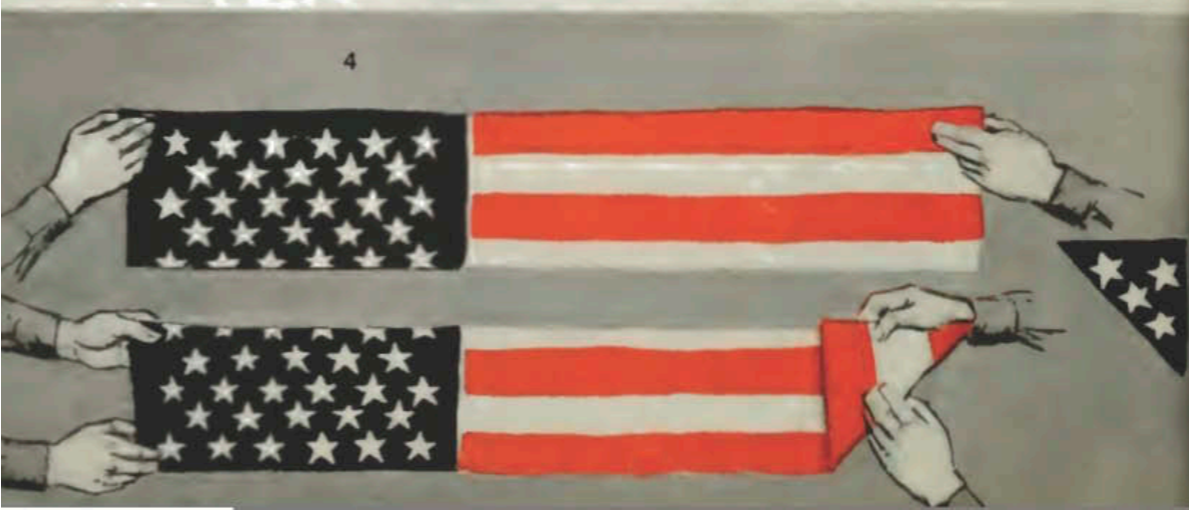

When the flag has left your arms, you step back and come to salute while the person raising the flag fastens the line to the flagpole.

In *lowering*, you salute while the other lowers the flag slowly; then you catch the flag, unfasten it, and help in folding it.

Taking Care of the Flag. The *folding* of the flag is done in a special way (4). First fold it lengthwise in halves, then in quarters, with the blue field on the outside. Now, while you hold it by the blue field, another Scout makes a triangular fold in the opposite end and continues to fold it in triangles until the flag resembles a cocked hat, with only the blue field showing.

The flag should be cleaned when soiled, mended when torn. When worn beyond repair, destroy it privately by burning.

Greeting Our Flag. *In Scout uniform*, with or without the cap, you greet the flag with the Scout salute whenever you see it being hoisted or lowered or when you pass it or are passed by it or when you give the pledge of allegiance to it. *In civilian clothes*, you greet the flag by placing your right hand over your heart.

When you pass the flag, come to salute six steps before you reach it and hold the salute until you are six steps past. When the flag passes you, come to attention and face it. Salute just before the flag reaches the point opposite you and hold the salute until it has passed. In formation, you salute at command of your leader.

When the flag is carried, there should be an honor guard on each side of it. When carried with other flags, the flag should be in front of the others or to the right if the flags are arranged in line.

The flag of the United States is never dipped in salute to any person or thing.



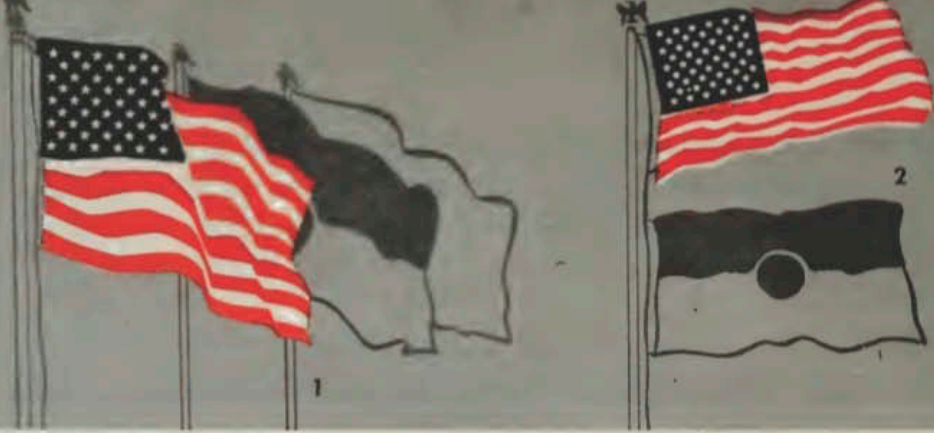

Displaying the Flag. As a Scout you must know the right way to display the flag from a pole or a staff, and on a wall.

Displayed on a flagpole in line with other flags on poles of the same height, the flag of the United States of America goes to its own right (1). It is hoisted first and lowered last.

Hoisted with a troop, city, or state flag, the flag of the United States is at the peak of the flagpole (2).

When displayed from a staff that projects from a window or from the front of a building, the flag goes to the peak of the staff, except when displayed at half-staff (3).

In a church or auditorium, the flag on a staff may be placed to the clergyman's or speaker's right whether the platform or stage he stands on is raised or not (4a). Or it may be placed to the right of the front row of the congregation or audience (4b).

When the flag is hung horizontally (5a) or vertically (5b) on a wall, the union should be to the top, at the flag's own right (to the left as you look at it).

Across a street, the flag is hung vertically with the union to the north in an east-and-west street, to the east in a north-and-south street (6).

Displayed with another flag with staves crossed, the flag of the United States should be on its own right, with its staff in front of the other (7).

In a group of flags on staves, the flag of the United States goes in the center (at the highest point) if its staff is longer than the other staves (8), or if the flags are arranged in a fan shape.

REMEMBER: The flag is never used as drapery (use red, white, and blue bunting instead). Nothing is ever placed on the flag. The flag never touches the ground, the floor, or water under it.



3

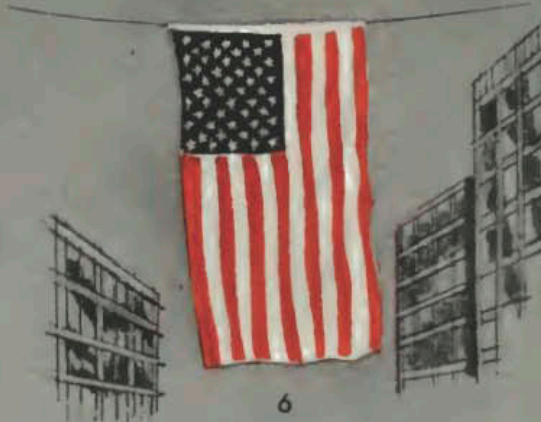

6



5b



5a



4a



5b



4b



7



8



KNOTS

You have probably already used some kind of knot around your home. For Scouting you need to know several more. You use knots in setting up your tent and in making camp gadgets. You use knots in pioneering and boating and canoeing. And someday you may even save a life because you know how to tie the proper knot.

Several years ago, a boy got the foolish notion to climb the rock wall of the Palisades of the Hudson River north of New York City. Halfway up he slipped and landed on a narrow ledge. Some people heard his cries for help and lowered a rope to him. He grabbed it eagerly, and the people began to pull him up. But soon his hands could hold on no longer. He let go of the rope and fell to his death. If his rescuers had been Scouts, he would most likely have been saved. Scouts would have tied a bowline in the end of the rope before lowering it so that the boy could have slipped the loop around his body.

6  *Whip the ends of a rope at least one-quarter inch in diameter. Tie correctly two ropes of the same size together with a square knot. Join two ropes of different sizes with a sheet bend. Tie a rope to a rail with a clove hitch. Attach a rope to a post or rail with two half hitches. Tie a bowline around your waist. Tie a taut-line hitch on a rope under tension.*

The Right Knot for the Right Use. The trick in knot tying is to use the right knot and to tie it correctly. The right knot holds when you want it to hold and unties quickly. The wrong knot may come untied when you put a strain on it or may jam so hard that you can't untie it.

You can teach yourself to tie the Tenderfoot knots by following the drawings carefully. But you will learn them quicker and have more fun if you get one of your patrol members to show you. Use real rope from the start—not string or twine. Get hold of a 6-foot length of $\frac{1}{4}$ -inch rope or larger. Practice tying it to a post and around yourself. To be certain that you really know the knots, try to tie them in the dark. You will not always have a flashlight when you need to tie a knot at night.



The short, free part of the rope is called the end. The rest of the rope is the standing part. When you bend the end so that it lies beside the standing part, you have a bight. By crossing the end over the standing part you make a loop. If you bring the end through the loop, you have made an overhand knot—or a half hitch if around a post. All knots are made by combining bights, loops, or overhand knots in different ways.



Before using a rope, whip the two ends to keep them from unraveling. To whip the end of a rope, use a piece of twine or cotton fishing line 2 feet long or longer. Make it into a loop and place this at the end of the rope. One-fourth inch from the end begin to wrap the twine tightly around rope. When the whipping is as wide as the rope is thick, pull out the ends hard and trim off the twine. Then whip other end of rope.



To join two ropes with a **SHEET BEND**, make a bight on one of the ropes—on the heavier one if they are of different thicknesses. Pass the end of the black rope through and around the bight, then follow the red arrow line under the black rope's standing part in the bight.



CLOVE HITCH is the most important knot for pioneering. You use it for starting and finishing most lashings that hold poles and timbers together.



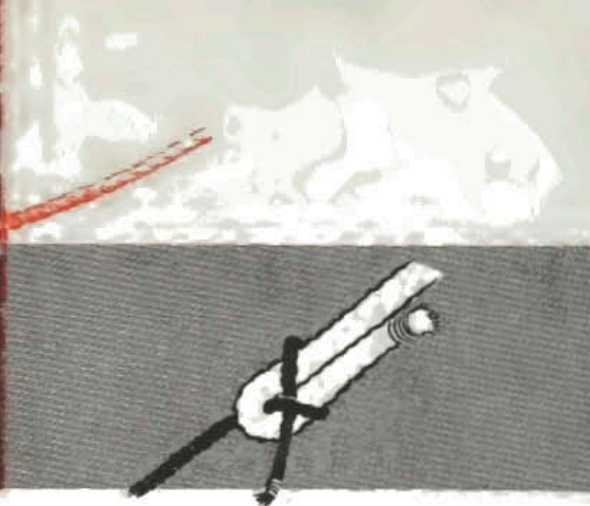

The SHEET BEND got its name from "bending" (tying) a "sheet" (a rope that holds a sail in place). A sheet bend is the best knot to tie two ropes together, whether of the same or of different thicknesses. Used for ages to make fishnets; it's also called a "weaver's knot."

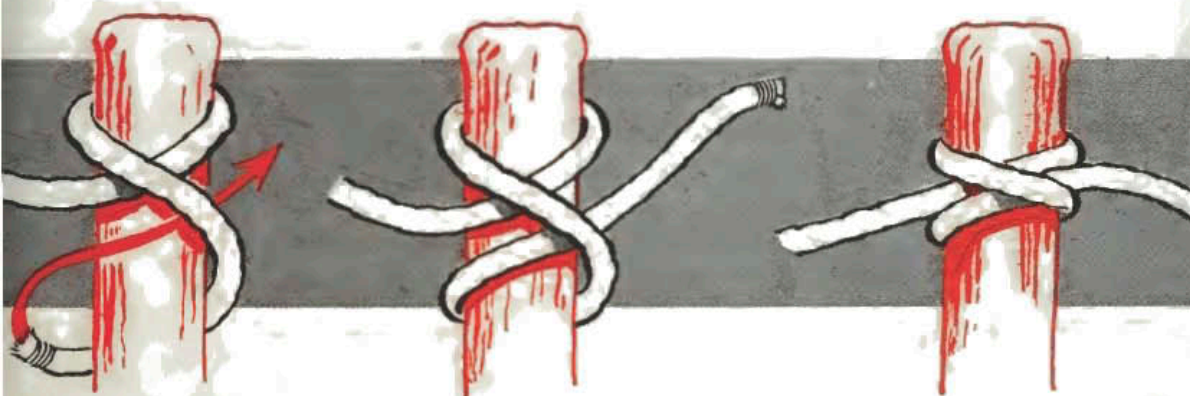

To attach a rope to a post or rail with a CLOVE HITCH, throw the rope end around the pole and lay it over its own standing part. Bring the rope end once more around the pole. Finish by carrying the end under the rope itself, then tighten the hitch as much as possible. "Hitch" is the name for a knot used for fastening a rope to a post.



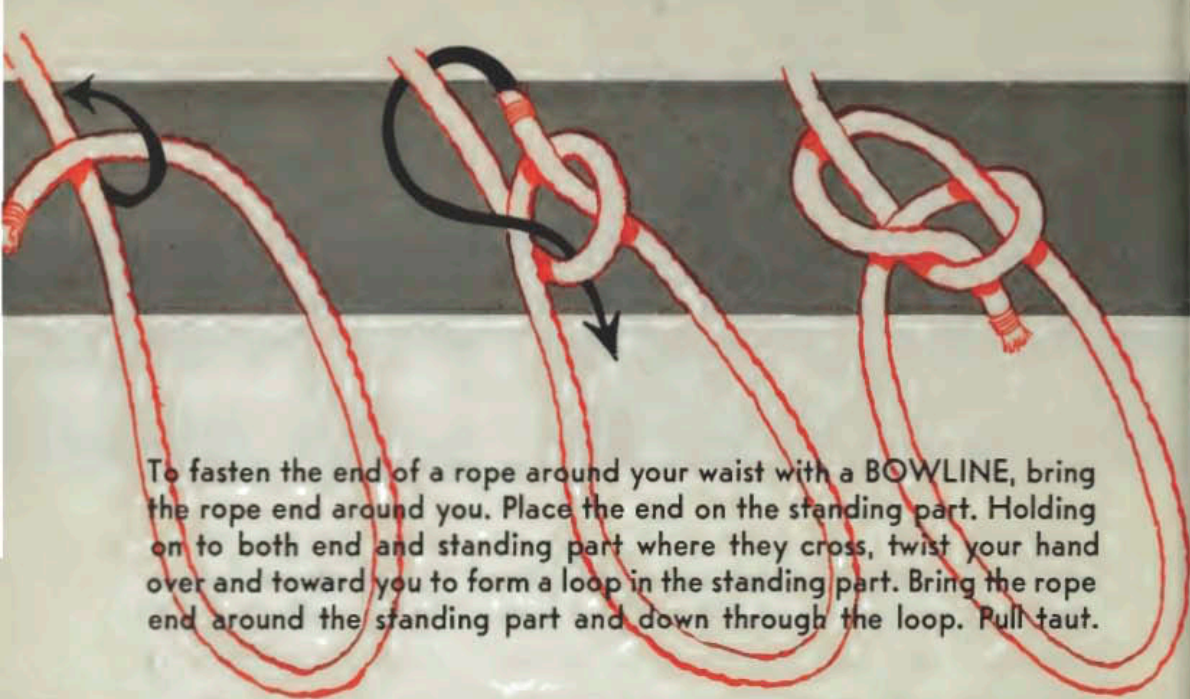



To fasten the end of a rope around your waist with a **BOWLINE**, bring the rope end around you. Place the end on the standing part. Holding on to both end and standing part where they cross, twist your hand over and toward you to form a loop in the standing part. Bring the rope end around the standing part and down through the loop. Pull taut.

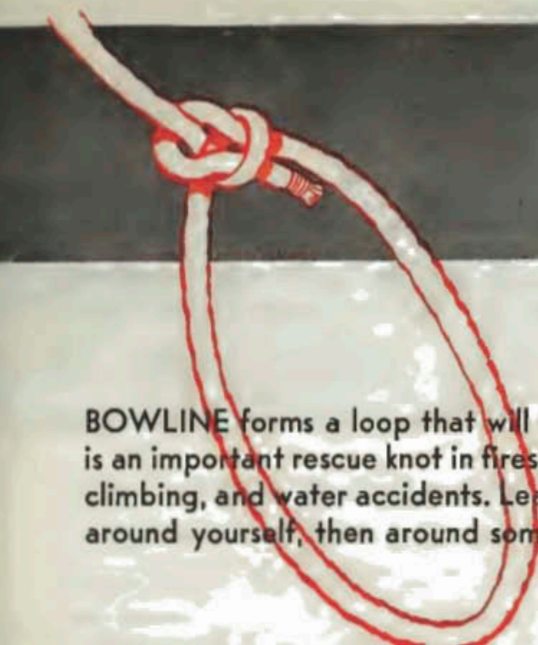

TWO HALF HITCHES is one of the simplest knots for tying a rope—such as a clothesline or the rope ("painter") of a boat—to a pole or a ring. It forms a loop that can be pulled tight yet which is easily loosened again.



BOWLINE forms a loop that will not slip. It is an important rescue knot in fires, mountain climbing, and water accidents. Learn to tie it around yourself, then around someone else.



To fasten a rope to a post with **TWO HALF HITCHES**, pass one end of the rope around the post. Bring the rope end over and under its own standing part and through the loop you have formed this way. Do the same once more in front of this first half hitch. Again bring rope end over and under the standing part and through the loop formed.





SQUARE KNOT is fundamentally a binding knot. It is used for tying up bundles and packages. On shipboard it is used for "reefing"—tying up—the sails. This gave it its old name of "reef knot." Its most important use is in first aid, for binding up a wound with a triangular bandage or with a gauze bandage. It holds firmly when it is tied right.

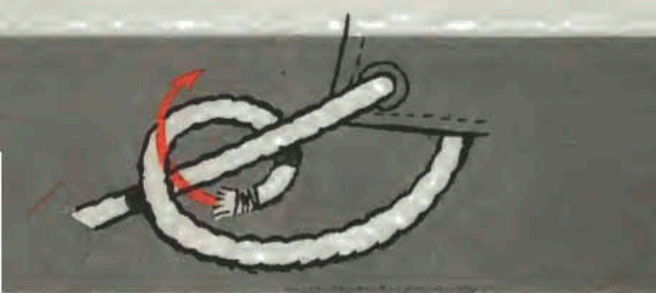

TAUT-LINE HITCH is the best hitch to use for your tent guy lines. It forms a loop that does not slip by itself as long as the rope is taut, yet slips easily when you push knot up or down. It is also important in rescue work when it is necessary to tie a loop on a line that is taut.

To tie a **TAUT-LINE HITCH**, pass the rope through the eye or around the pole to which you want to attach it. Carry rope end around the standing part twice and through the loop thus formed. Then carry the rope end around once this time and pull taut. Finally adjust the knot.



To tie a SQUARE KNOT, hold one rope end in one hand, the other rope end in the other. Twist left-hand rope end over, behind, and under the right-hand rope end, and pull taut. Once more twist the same rope end over, behind, and under, and pull taut. When tied correctly, the end of each rope lies next to its own standing part.





Outdoor Code

As an American, I will do my best to—

BE CLEAN IN MY OUTDOOR MANNERS—I will treat the outdoors as a heritage to be improved for our greater enjoyment. I will keep my trash and garbage out of America's waters, fields, woods, and roadways.

BE CAREFUL WITH FIRE—I will prevent wildfire. I will build my fire in a safe place and be sure it is out before I leave.

BE CONSIDERATE IN THE OUTDOORS—I will treat public and private property with respect. I will remember that use of the outdoors is a privilege I can lose by abuse.

BE CONSERVATION-MINDED—I will learn how to practice good conservation of soil, waters, forests, minerals, grasslands, and wildlife; and I will urge others to do the same. I will use sportsmanlike methods in all my outdoor activities.



PROTECT THE OUTDOORS

As a Scout, you will spend much of your life in the open. All of America will lie before you—her forests and fields, her mountains and valleys, her rivers and lakes. The natural resources of our country are yours to enjoy and use wisely.

7  *Read the Outdoor Code. Tell how you will try to use it in the hiking and camping you will do as a Scout.*

Our Natural Resources. The natural resources of a country include its soil and waters, its plants and animals, its minerals. In this respect, America is one of the richest countries in the world.

Our soil gives us food in abundance—bumper crops of corn and wheat and vegetables. Our grasslands teem with cattle that provide us with milk and meat and leather. Our forests give us products that range from the wood we use for building our homes to the maple syrup you pour on your pancakes—but are important also for being a source of pleasure to you and other hikers and campers, for giving food and shelter to wildlife, for regulating the flow of streams and cutting down flood dangers. As far as minerals are concerned, few countries can match the variety and wealth of America in metal ores and coal, oil and natural gas, and many other things.

But soil can be lost if it is not properly cared for, water can be polluted, grasslands and forests and wildlife can be destroyed by fire, minerals can be wasted.

America's natural resources are part of your God-given heritage. It is your duty as a Scout and a citizen to protect them and conserve them—for your own sake and for the sake of every other American.

How can you do it?

You can do it most easily and most effectively by living up to the Outdoor Code developed by the Boy Scouts of America for all Americans. Study it carefully and make up your mind to follow it.

It is easy to live up to this code. It is mostly a matter of doing the thoughtful thing instead of the thoughtless one—picking up trash instead of dropping it, using care with fires, thinking of others before yourself.

Using the Outdoor Code

Be Clean in Your Outdoor Manners. One of the saddest things you can see in the outdoors is a beautiful countryside scarred with pieces of papers, empty cigarette wrappers, sodden cardboard containers, rusting tin cans, broken bottles. Few Americans would think of strewing this kind of trash around in their own living rooms. Yet many of them think nothing of strewing it in the "living room" that belongs to all of us—our country's great outdoors.

Rubbish has no place in the American landscape. If you suffer from the sad "dropping habit" that so many Americans have, get rid of it! Make up your mind from your earliest days as a Scout to hike and to camp without leaving a trace of rubbish behind.

When hiking, put sandwich papers, candy wrappers, and similar "pocket trash" in your pocket until you can throw them into a waste container or into your waste-paper basket at home.

When camping, get rid of burnable garbage by burning and carry unburnable garbage out with you to be deposited in the nearest waste container. Never break bottles and never throw them in the fire. Never throw cans about and never bury them—if buried, animals dig them up in short order. Instead, deposit bottles, jars, and cans in a waste container. If none is at hand, take them with you for proper disposal.

Before starting a fire, the real outdoorsman prepares the spot so that he is positive the fire cannot spread.



Be Careful With Fire. Each year in our country more than 9 million acres of woodlands and grasslands are laid waste by fire. Just imagine: an area the size of Massachusetts and New Jersey together destroyed by fire in a single year! Imagine a whole state going up in flames because of some people's carelessness with fires in the open!

You would certainly not want to be the cause of any of this destruction. If you have occasion to build a fire in the outdoors, you will want to make certain that your fire is a **SAFE** fire.

PREPARING THE FIRE SITE—Build a fire only on a spot where you have complete control over it and from which it cannot spread. To be certain, clean the site down to mineral ground—sand, gravel, clay, or rock—and clear it for a diameter of 10 feet of any material that may catch fire from a flying spark—dry grass, dry leaves and twigs, pine needles, and the like.

MAKING THE FIRE—Make a small fire, just big enough for the job it has to do.

After a Scout has lit a fire, he doesn't casually throw away the match—first he breaks it in two. The breaking itself is not the point—the point is that you can't break a match without touching the burned part, and you will then know quickly enough whether the match is **OUT** or not.

From the moment a fire is lit until it is extinguished, someone must watch it to be positive that it does not get out of control. To be extra safe, have a container of water near the fire.

EXTINGUISHING THE FIRE—When you no longer need the fire, extinguish it. A fire is not extinguished when it is "just" out—it must be **DEAD** out! Sprinkle water on the embers. Stir the wetted-



Make a small fire and put it out completely after using it.



down embers with a stick and sprinkle again. Turn over half-burned twigs and wet them down on all sides. Wet the ground around the fire.

If water is scarce, work mineral dirt into the ashes, then stir and stir again until the last ember is out. Test for this with your hand. A fire is not OUT until the last spark has been KILLED.

Some campers place two small sticks crosswise over the dead ashes of their fire to show that it was out when they left. It is even better to "garden" the wet ashes into the ground and make the spot look so natural again that no one will know that you were there.

Be Considerate in the Outdoors. When hiking and camping, treat property and other people the way you would want to have your own property treated and the way you would like to be treated by other people. Be considerate, in your behavior, of other people's feelings and desire for privacy.

Never trespass private property. If you would like to hike across somebody's land, get the owner's permission—he will probably gladly give it to you.

Wherever you go camping you are on somebody's property. On private land you'll ask for permission and will live up to any restrictions the owner may place on the use of his grounds. On camp property belonging to your local Boy Scout council you are on land of which you are part owner—your local council is yourself and all the other Scouts and leaders of your community—so, of course, you will want to treat it right. In state and national parks you are part owner, too, with 190 million other Americans. Here again, you will want to treat the property well.



Be Conservation-Minded. The more you travel in the outdoors, the more will grow your desire to protect our natural resources for your own use and for the future and to do your part in their conservation.

Some kids who don't know any better start hacking the moment they carry a knife or an ax out in the open. They don't realize that a scar into the bark of a tree is like a wound into the skin of a human being: The tree may bleed to death by losing its sap or various diseases may enter into the scar and eventually kill the tree.

Fortunately, a boy who becomes a Scout has another idea. He never harms a tree. If he needs wood for a fire, he looks for dead branches and twigs. If he needs a pole for a tent or a camp structure, he cuts it by permission only and then in such a way that the cutting will improve the woods rather than detract from them.

Similarly, he does not disturb the soil unnecessarily. If he has to dig up sod to clear a spot for his fire, he replaces the sod carefully afterward. He does the same if heavy rain has forced him to ditch around his tent.

After once becoming conservation-minded, you will want to swing into action in the conservation activities planned by your patrol and troop. You may then have a chance to help plant a thousand trees, to improve a brook for trout, to save a streambank from washing away, to put up brush shelters for rabbits and other small animals and many other things.



YOUR LIFE IN SCOUTING

A few years from now you'll be a man—and every real man wants to make good. The skills you learn will count a lot. So will your enthusiasm and initiative. But one of the most important things will be your ability to work with other people. In Scouting you have a wonderful chance for learning what teamwork means as you live your Scouting life in patrol and troop.

YOUR BOY SCOUT PATROL

The Scout patrol is the finest boys' gang in all the world. The patrol is the unit that makes Scouting go. It is a group of boys, usually six to eight, who pal together because they like to do the same things.

A patrol is a team, with all the fellows playing the game of Scouting, with all of you working toward the same goal, with all of you having a whale of a good time. And why shouldn't you? In the patrol you learn what fun it is to go hiking and camping with



your best friends . . . to build your own fire and cook your own food . . . to swim, to dive, to paddle a canoe . . . to live your life according to the Scout code . . . to sit around a glowing campfire.

Your Patrol Leader. Naturally, no gang of boys can turn into a good Scout patrol unless it has a good leader. So the fellows make sure to choose the Scout they respect the most as their patrol leader—one who has the energy and will to work and the enthusiasm to make the patrol the finest ever.

The patrol leader is responsible for what happens in the patrol. He says to the rest of the gang, "Come on, let's go!" and starts off. He leads the patrol at patrol and troop meetings, on hiking and camping trips. He suggests Good Turns for all of you to do, thinks up ways for his fellows to get somewhere in Scouting.

It is up to all of you in the patrol to follow your patrol leader through thick and thin. You've got to stick together for the good of the patrol. At times you must be willing to give up cheerfully some of your own comforts if it will benefit the patrol.

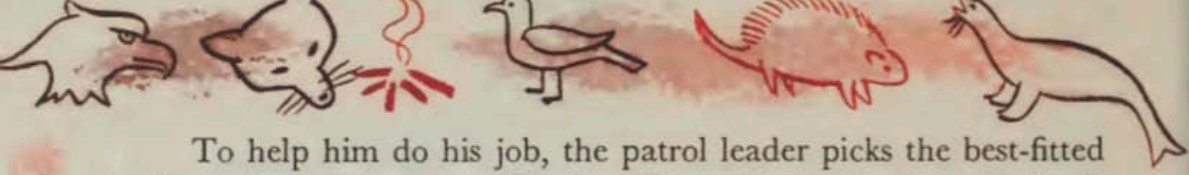

To help him do his job, the patrol leader picks the best-fitted Scout for assistant patrol leader. The assistant takes over the leadership when the patrol leader cannot be there.

There is a job for everyone in the patrol—for you, too, even if you are just joining. One fellow is the patrol scribe who writes up the record of the patrol in the patrol's history book. Another is the patrol treasurer who collects dues and keeps the money score. The patrol quartermaster has charge of patrol equipment, and the patrol's hikemaster, grubmaster, and cheerleader help make every hike and camp a success.

8a  Explain the name of the patrol you will join and give its call or yell.

The Name of Your Patrol. Every patrol has a name of its own. If you join an old patrol its name will have a lot of history and tradition behind it. You bet! Every fellow will be proud of it. A new patrol, on the other hand, spends a lot of time discussing a name before deciding on one that will really fit.

Most patrols pick the names of animals or birds. Those names have the real flavor of the out-of-doors. A Maine patrol that has tracked a moose on a nature hike may decide to become the Moose Patrol, while a Florida patrol may call itself the Alligators.

Or how do names like Diving Seal Patrol, Roaming Buffaloes, Speedy Beavers, or Silent Panthers strike you? Naturally you'll expect the Seals to be experts at swimming, the Buffaloes real

The patrol leader's badge has two green stripes, the assistant patrol leader's has one. That's why these leaders are often referred to as "Green Bar Men."



John Smith



NAME OF MY PATROL IS

MY PATROL CALL IS

PATROL NAMES AND CALLS

Alligator	Grunting hiss
Antelope	Shrill snort
Bat	High squeak
Bear	Deep growl
Beaver	Clap hands sharply once
Bob White	"Bob-bob-white"
Buffalo	Lowing "Um-mooww"
Crow	"Caw-caw-caw"
Cuckoo	"Cook-koo"
Eagle	Shrill "Kreeee"
Flaming Arrow	"Whsssss"
Fox	Sharp bark
Hawk	High shrill whistle
Moose	"Oh-ah, oh-ah, oh-ahhh"
Owl	Loud "Coo"
Panther	"Keeook"
Pelican	"Clap-clap-clap"
Pine Tree	Whistle imitating wind
Raccoon	Thin whine "Mm-mmm"
Rattlesnake	Rattle pebbles in can
Raven	"Kar-kaw"
Seal	Sharp bark
Whippoorwill	"Whip-poor-will"
Wolf	Loud howl "Hoo-ooo"

For other names make up your own patrol call.



hikers, the Beavers tops at pioneering, the Panthers masters in stalking. Something to aim for!

Patrol Flag and Emblem. Your patrol has a flag that displays the emblem or “totem” of your patrol. The best kind of patrol flag is one the gang has made itself—from the first idea of its design to the special secret marks on it. How proud you feel as you carry it on the hike or see it fluttering in the breeze over your patrol camp!

You wear the patrol emblem on the medallion on your right sleeve for the same reason—to show your pride in your patrol, to tell the world where you belong and what you stand for. Probably you also stencil your emblem on your pack, your tent, and other camping gear. You learn to draw the patrol emblem with a few quick strokes and add your “totem” to your signature whenever you sign your name.

The best patrol in the troop—you’re part of it!

Patrol Call. Your patrol has a call—the cry of your patrol animal. As a Moose or a Hawk or a Fox or an Owl, you use the call of your namesake—the bellow of the moose, the whistle of the hawk, the bark of the fox, the hoot of the owl. Even if the gang is not named for an animal, you will still have an animal call for



At patrol meetings, you help plan for the great activities you want to have in Scouting.



a patrol call. Indians used animal sounds for warnings; explorers attract the animals they want to study by imitating their calls.

The patrol call is meant to be used. You give the call softly under your buddy's window, and he quickly joins you. In deep woods, your patrol leader sounds the call for the gang to gather—the fellows in the patrol know what is up while others will think that it is just one of the natural calls of the woods.

8b  *Discuss the importance of your patrol to your Scout activities.*

Patrol Doings. An honest-to-goodness, live-wire patrol does plenty of things on its own. It always has a lot of interesting plans underway, whether patrol meetings, hikes, camps, Good Turns, stunts, making tents, fixing up a patrol den.

Patrol meetings are held regularly in the homes of the members, in the patrol's own den, or in the troop meeting room. The meetings are planned in advance by the patrol leader with the help of the rest of the patrol, and there's something for everyone to do.

It is at patrol meetings that you fellows help each other advance in Scoutcraft. It is here that all the great things you want to do are decided on. It is here that your friendships grow.

The good patrol, under a trained leader, has its own patrol hikes and camps from time to time. Those hikes and camps are the high spots in the patrol's life. It is around the fires of the gang that patrol spirit reaches its peak, where each of you comes closest to the heart of Scouting.

The patrol flag follows the good patrol wherever it goes—on hikes and camps.



YOUR BOY SCOUT TROOP

The patrol does not stand alone. It is part of the troop. And just as certainly as the patrol belongs to the fellows in it, the troop belongs to the three or four or more patrols that make it up.

Around your neck you wear the neckerchief in your troop's colors. On your left sleeve you wear the troop number. Every Scout is proud of his troop. Every Scout does his best so that the troop, in turn, will be proud of him. For years to come, you'll be a member of that good old troop; and, while living in it, you'll build memories that will last a lifetime—of troop songs around the fire on a cold winter's night, swims at camp, treasure hunts, father-and-son camps, parents' nights, courts of honor, troop Halloween parties, Thanksgiving Good Turns!

The way in which you make certain of that kind of memories is by getting behind the troop leaders and backing them up in their work to make your troop the very best.

Your Troop Leaders. Now, who are your troop leaders?

First, there's your Scoutmaster. What a wonderful man he is! He spends hours figuring out how to give you fun and adventure in your troop. He takes special training to learn exciting new things for you to do. He is present at every troop meeting and goes hiking and camping with the troop. He is the friend to whom you can always turn for advice. He coaches the patrol leaders. Why does he do all this? Because he believes in Scouting, because he likes boys and wants to help them become real men.

Your assistant Scoutmasters help your Scoutmaster and take charge of the troop when needed. Like the Scoutmaster, they spend a great deal of time in training and planning and working in your behalf. A patrol dad may be helping your patrol.

Then there's the senior patrol leader who helps all the patrols with their program and is generally in charge of troop meetings, and the junior assistant Scoutmasters who are responsible for special activities such as games and contests.

Behind these leaders is a group of men—the troop committee—responsible for the troop's welfare and ready to help it. And behind these, in turn, is the chartered institution—the church or syna-

gogue, school, or service club—that has accepted the Scouting program as one of its ways of helping boys.

The Patrol Leaders' Council. The activities of the whole troop are planned by the patrol leaders' council. This council is made up of the patrol leaders, the senior patrol leader, and the Scoutmaster. Other leaders may be invited if their help is required.

It is through this council that the boy leaders assume their responsibilities for running the troop and get the training they need to make their patrols efficient. The patrol leaders' council meets every month to arrange the details of troop meetings, hikes, and camps. Before each council meeting, your patrol leader talks over with the patrol what ideas you have, then brings them with him to the meeting to pass on to the other leaders.

Troop Doings. All the patrols of the troop get together regularly at troop meetings. In some cases, troop meetings are held every week. Other troops may meet twice a month.

Troop meetings are taken up with games—some for training, some just for fun—and with contests between patrols so that you have a chance to show how good you are. Demonstrations and instruction in different kinds of Scoutcraft are also parts of the troop meeting. So are songs, stunts, and ceremonies.

On troop hikes and in troop camps, every fellow learns how to take care of himself in the outdoors in all kinds of weather, and the patrols become skilled and self-reliant.

It is by taking part in all the activities of your troop and your patrol that you learn to be a Scout.

Summer camp with the troop—that's an adventure all Scouts look forward to.





YOUR ADVANCEMENT

Hundreds of years ago, an old Chinese philosopher said, "A journey of a thousand miles starts with but a single step." The same holds true in Scouting.

Becoming a Tenderfoot Scout is but your first single step in Scouting. There are many other steps you need to take before you can prove yourself a real Scout.

You will be encouraged in taking all of these steps through the special advancement program of Scouting.

Advancement in Scouting. The advancement program of Scouting provides a forward-moving series of tests. It sets standards for passing them. It offers awards to the Scouts who master them, in the form of special badges. As long as you are just a Tenderfoot Scout, that badge is only part of the complete Scout badge—the upper, three-pointed part. When you pass other tests, you are granted the right to wear, first, the scroll that shows that you are a Second Class Scout and, next, the complete badge that tells you have reached First Class Scout rank. And this is only the beginning. The ranks of Star, Life, and Eagle lie ahead.

Scout advancement is something very special. In most other kinds of learning, you are taught in a class, doing a certain amount of work in a certain length of time. In such a class the brighter boys are held back by those less bright, and the slower boys are pushed ahead faster than they are able to grasp the subject. In Scout advancement, on the other hand, each boy proceeds at his



As you advance in Scouting, the badges on your uniform change—from the parts of the Scout badge to the full badge for First Class.

own speed. Your rate of advancement depends entirely on your ability and interest and ambition.

How To Advance. As you study the tests for the different ranks, you will see that there is a certain pattern to them. For all ranks, you are required to show a good attendance record. You are required to master certain skills. You must show that you know the ideals of Scouting and are trying to live up to them.

By taking part in all the regularly scheduled activities of your patrol and troop, and by living Scouting in your daily life, you can't help but learn the skills and meet most of the other tests. But you need to make an extra effort to wind up the final tests each time you want to reach a higher rank.

Make up your mind that you want to get as much out of Scouting as Scouting has to offer. Make up your mind to move as far up in Scouting as your ability permits. But most important in these decisions: Make up your mind right now to take your next step in Scouting—from Tenderfoot to Second Class—as quickly as possible.

9 ♣ *Review briefly the things you will do to become a Second Class Scout.*

Onward to Second Class. Read carefully the description on page 101 of what you have to do to become a Second Class Scout and study the tests on pages 102 to 105. Then set out to pass them!



**ON THE HIKING TRAIL
SECOND CLASS**





MY SECOND CLASS SCORE

<input type="checkbox"/> / 19.....	Active Service	106
<input type="checkbox"/> / 19.....	Hike Precautions Three Hikes	110
<input type="checkbox"/> / 19.....	Hike No. 1	
<input type="checkbox"/> / 19.....	Hike No. 2	
<input type="checkbox"/> / 19.....	Hike No. 3	
<input type="checkbox"/> / 19.....	Map Reading	126
<input type="checkbox"/> / 19.....	Compass	132
<input type="checkbox"/> / 19.....	Follow Map and Compass	133
<input type="checkbox"/> / 19.....	Lost	137
<input type="checkbox"/> / 19.....	Poisonous Plants	141
<input type="checkbox"/> / 19.....	Wildlife	142
<input type="checkbox"/> / 19.....	Trailing*	161
<input type="checkbox"/> / 19.....	Tracking*	163
<input type="checkbox"/> / 19.....	Stalking*	166
<input type="checkbox"/> / 19.....	Knife and Ax	170
<input type="checkbox"/> / 19.....	Cooking	176
<input type="checkbox"/> / 19.....	First Aid	186
<input type="checkbox"/> / 19.....	Scoutmaster Conference	206
<input type="checkbox"/> / 19.....	Board of Review	

*Only two needed.



how to become a SECOND CLASS SCOUT

A hundred years ago, when the far West was being settled, adventurous young men with courage arrived from the East eager to make a new kind of life for themselves. The old-timers, already hardened to the roughness of pioneer life, called them “tenderfoots”—their feet were still smarting from the long trek, their bodies still soft.

The newcomers didn't care much for the name of “tenderfoot.” To get rid of it they quickly set out to prove that they had what it takes, by turning themselves into first-class lumbermen or miners or cattlemen.

It's the same in Scouting. In the beginning, you're just a Tenderfoot Boy Scout. No Scout—and certainly not you—wants to stay “tenderfoot” for long. You want to prove yourself first class in every way—in the way you fit in with the gang, in the skills you learn, in the spirit you pick up.

A jump directly from “tenderfoot” to “first class” would be quite a jump! That's why Scouting provides you with an in-between stage. From Tenderfoot you advance to Second Class, and only then reach for the higher goal of First Class.

What You Have To Do. Aim to become a Second Class Scout as quickly as possible after you have joined the Boy Scouts. If you can manage to do it in the minimum time that is required, of 1 month, by all means do so. If not, set a date for yourself not long afterward for getting the tests passed. You will discover that it is easy to pass them once you have made up your mind.

To become a Second Class Scout you must, first of all, show that you intend to be an *active* Scout. You do this by taking part, regularly and wholeheartedly, in all the activities of your patrol and your troop and by doing your share to make each of these activities a success.

Then there are certain Scoutcraft skills you have to master. The skills for becoming a Second Class Scout are hiking skills. You'll pick them up easily on the hikes of your patrol and your troop. You'll learn to prepare yourself for safe hiking, to find your way through woods and fields, to track and stalk an animal, to cook a meal in the open, to handle an emergency, to have fun in the out-of-doors.

As you live the life of a Scout in patrol and troop, you'll soon catch the spirit of Scouting. The Scout Law will become your code of conduct in your everyday life. The Scout motto will be your spur to learning. The Scout slogan will inspire you to do your daily Good Turn. You will learn to show your Scout spirit by your actions—in the way you act at home, in your school, your church, your community.

Review and Award. When your Scoutmaster is satisfied that you have passed all the Second Class tests, he arranges for you to meet with your troop board of review. This board consists of at least three members of your troop committee. They do not examine you all over again—their task is to check that you have passed all the tests "fair and square." After the board of review has made sure that you are qualified, it approves you for advancement in rank.

At an early troop meeting, your Scoutmaster arranges for a court of honor ceremony.

The Tenderfoot badge disappears from your shirt pocket. The Second Class badge takes its place. Congratulations!



S E C O N D C

To become a Second Class Scout, you must show by your attendance record that you have been active in troop and patrol meetings and activities for at least 1 month since becoming a Tenderfoot Scout. While a Tenderfoot Scout, do the following:

1. Tell what precautions must be taken for safe hiking.
2. (a) Take three hikes, each on a different day, of not less than 5 miles each with your troop, your patrol, an adult, or another Scout who is at least Second Class. (b) Before each hike, submit a hike plan for approval (unless this is a troop hike) to your Scoutmaster or an adult assigned by him. (c) Before leaving on each of these hikes, present yourself (to your hike leader or companion) for inspection suitably clothed for the locality, season, and weather and equipped for the occasion. (d) On each of these hikes, observe proper hike precautions. (It is suggested that Tests 5, 7, and 10 be completed on these hikes.)

If a physician certifies that the Scout's physical condition for an indeterminable time does not permit the Second Class test hike, the advancement committee of the local council may authorize the following substitution for the hike: the requirements for any one outdoor merit badge of a comparable nature that the Scout is capable of meeting.

S S T E S T S

In EACH case, application for a substitution must be made in advance by the Scoutmaster to the advancement committee on a special standard form provided for this purpose. Application for Substitution for Basic Scout Requirements, No. 4434, and the specific substitution must be approved in writing by the committee, after thorough review. Other ranks for which an application for substitution may be made include First Class, Star, and Life Scout. A boy, to become an Eagle Scout, must meet all requirements or qualify using Application for Alternate Eagle Requirements, No. 6101.

3. Identify on a topographic map at least 10 different map symbols including contour lines.
4. (a) Explain how a compass works. Give its eight principal points. (b) Set a compass and use it to read at least three bearings in degrees.
5. (a) Show how to orient a map. (b) Use a map (preferably a topographic map) and a compass to follow, far enough to prove your ability, a route indicated on the map.
6. (a) Explain how to keep from getting lost. (b) Explain what you would do if you did become lost.



7. (a) Identify local plants that may cause skin poisoning. (b) Find in the field 10 different kinds of wildlife (mammals, birds, reptiles, amphibians, fish, insects) or evidence of them. Tell what they are, describe the natural surroundings where each was found, and explain how this wildlife depends on plants.
8. Do two of the following:
 - (a) Follow for a half mile a trail made with trail signs or by a person wearing tracking irons or dragging a whifflepoof.
 - (b) Follow for a quarter mile the track of a person or animal in soft ground or snow, reading the main meaning of the track.
 - (c) Follow another Scout who knows that you are stalking him for a distance of a half mile, without being seen by him.
9. Correctly sharpen a knife and ax and give rules for their safe use.
10. (a) Use an ax correctly to prepare kindling or fuel wood. (b) Build a fire on a safe spot using not more than two matches. On this fire, (c) cook—without utensils—a meal from raw meat (or fish or poultry) and at least one raw vegetable. (d) Properly dispose of garbage, put out your fire, and clean up the cooking area.

The term "without utensils" means without such items as cook kits, foil, tin cans, and other items manufactured



for cooking purposes. Native materials such as kabob sticks, greenstick broilers, etc., may be used where permissible.

11. (a) Tell how, in an emergency, you would reach a doctor or a hospital. (b) Explain what first aid is and tell how to act in case of an accident. (c) Show how to handle "hurry cases" of arterial bleeding and stopped breathing, and tell what to do for poisoning by mouth. (d) Demonstrate first aid for shock and fainting. (e) On yourself, show what to do for cuts and scratches, burns and scalds, blister on heel, bites or stings of insects and chiggers and ticks, skin poisoning from poison plants, sprained ankle, object in eye, nosebleed. (f) Show how to sterilize a dressing.

12. After completing the above tests, meet with your Scoutmaster (or an adult assigned by him) in a personal conference. At this meeting, complete to his satisfaction the following:
 - (a) Discuss your ideas about the meaning of the Scout Oath (or Promise), the Law, motto, and slogan; and give examples to show that you do your best to live up to these ideals in your daily activities.
 - (b) Describe several Good Turns you have done and explain how you think they helped others.
 - (c) Look over the tests for First Class and discuss how you intend to progress toward that rank.



YOUR LIFE AS A SCOUT

America is a democracy in which every citizen plays an important part. It is by teamwork that America has grown strong. It is by teamwork that it will remain strong. Similarly, it is by working and playing with your fellow Scouts as an active member of a team that you will learn to be a real Scout and, in the process, will help strengthen your patrol and your troop.

 *To become a Second Class Scout, you must show by your attendance record that you have been active in patrol and troop meetings and activities for at least 1 month since becoming a Tenderfoot Scout.*

Your Life in Your Patrol. Take a good look at that word “teamwork.” It is made up of two little words that go back to Anglo-Saxon days: “team” and “work.” “Work” has always meant just that, although it was originally spelled “weorc.” But “team” we are not so sure of—it may have come from “team” which means “family” or from “teon” which means “to pull.” By taking both of these old meanings, you have the perfect definition for “team”—“a family pulling together.”

That’s exactly what a Boy Scout patrol is: a family and a small democracy in which you have rights and duties.



Here you practice being a good citizen by working with others for everyone's good. Here you learn to respect the opinions of others. Here you show your loyalty and helpfulness and sense of fair play.

Every week, probably, you will meet with your patrol—alone or with other patrols for troop activities: meetings, hikes, camps, service projects.

Help make your patrol good. A good patrol is one in which there is full attendance, in which everyone takes an eager part in everything that is planned. When the gang sets a date and a time for a hike or a camp or for getting a job done, be there, on the dot, rain or shine. A "sunshine Scout" isn't of much value to a patrol or to himself. It's the "all-weather Scout" who makes a patrol hum and, at the same time, helps himself grow into an all-round boy.

Most patrol activities are planned by the whole gang. Your patrol leader is full of ideas—that's one of the reasons why he was chosen. He will suggest things to do, you will all be in on deciding and will all pitch in on whatever is decided.

But remember that your patrol leader is not the only fellow with ideas—each of you has a chance to suggest things that will keep the patrol rolling.

If you have an idea, give it. Your first idea may not be accepted by the gang, but someday you'll come up with one.

Set out to advance in rank at a steady rate. Become Second Class as soon as possible, work toward First Class, earn merit badges. It is only when every member of the gang keeps moving ahead that you'll have the kind of patrol you'll all be proud of.

Accept whatever patrol duties may come your way and carry them out to the best of your ability. If you have some special skill, the fellows may elect you for a patrol job: scribe, treasurer, hikemaster, grubmaster. If you show real leadership ability, they may even select you, someday, to be patrol leader.

Be on the lookout always to keep your patrol strong by bringing new boys into it. You may have a friend who should be a Scout. Invite him to visit the gang. If he joins, help your patrol leader get him ready for his Tenderfoot tests.

Many ambitious patrols make their own camp equipment and earn the money for buying things they can't make. You will get an extra thrill out of sleeping in a tent you helped make or swinging an ax you helped buy.

Give your patrol the best that is in you. Be proud of your patrol—and your patrol will be proud of you.

Your Life in Your Troop. What goes for the patrol goes for the troop as well.

"A chain is as strong as its weakest link." A troop is as strong as its weakest patrol.

Give your Scoutmaster and the other troop leaders your 100 percent cooperation. They plan and work to help you grow into strong manhood. Make use of all the opportunities they give you by taking part faithfully and enthusiastically in all troop activities.

Swing into action with the gang in every activity planned by the troop.



Come to troop meetings promptly and swing into games and contests and projects with all the energy and enthusiasm you have. Show up for a troop hike on time no matter what kind of weather. Aim to become one of the troop's best outdoorsmen.

Do Your Share—and Then Some! Your troop leaders may call on volunteers from time to time to get a special service job done. Step forward without hesitation—you'll have company.

Your patrol leaders' council may plan a service project that will require the efforts of the whole troop—a project in conservation, for instance, to improve a streambank or your favorite campsite. Get in there with the gang and get the job done.

A National Good Turn may be coming up. By joining in with the rest of the fellows, you'll get the work done in a hurry; and you'll feel good about helping your country and yourself at the same time.

The big thing to remember all the way through is that what happens in the patrol and in the troop—whether meetings or hikes or camps or service projects—happens because of YOU and other fellows like you. But keep in mind also that your patrol and your troop—yes, our whole Boy Scout movement—succeeds because of YOU and fellows like you.

Scouting is for YOU and *with* YOU. You will get as much out of it as you put into it.

Do your share to turn your patrol into the best outfit in the troop.

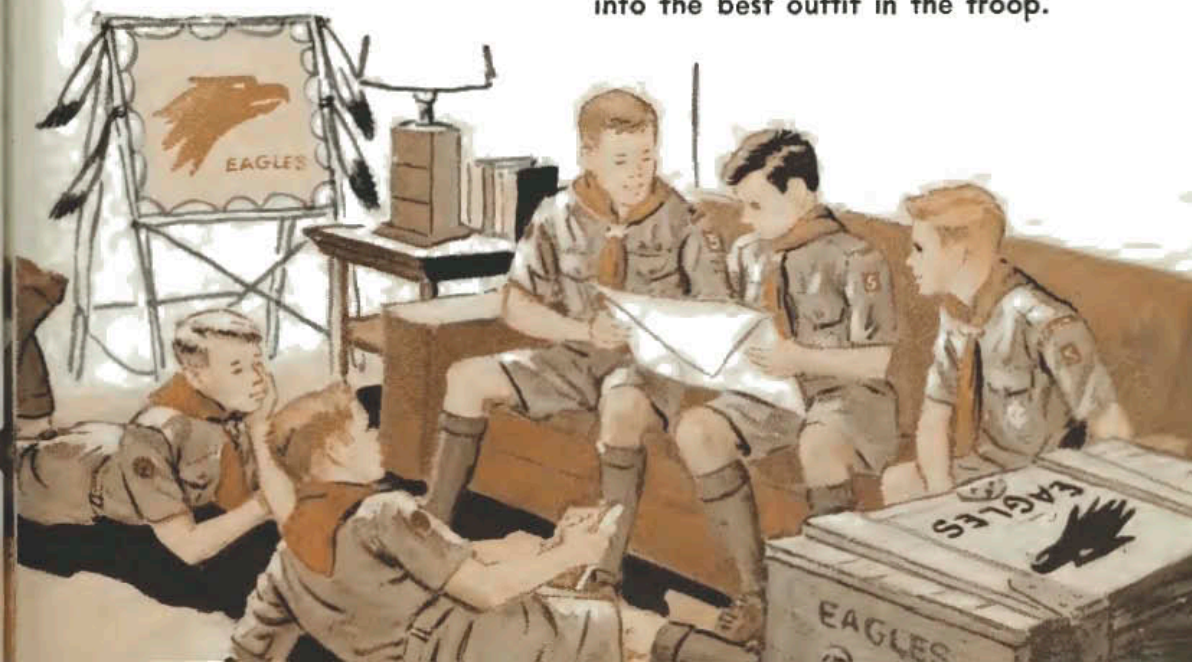



LET'S GO HIKING

Why hike? Because you are an American boy! Because roaming is in your blood and hiking gives you an outlet for your roving spirit.

The Revolutionary War that gained America her independence was a hiking war, and the whole vast country that is ours today was won by hikers. The early settlers for a while stayed close to the eastern shore of America. But the more adventure-some among them struck out for the unknown. Men and women, boys and girls, left the safety of the East and hiked westward through forests and over mountains, across prairies and plains and deserts and still more mountains—until the American dream spanned the continent from the wide Atlantic to the blue Pacific.

And as they traveled, they conquered every obstacle in their way with the same woodsmen's tools that Scouts use today, with the same pioneering skills that Scouts practice today, with the same steadfast spirit that Scouts show today.

There's adventure in hiking—following the trails of those who built America, penetrating what is left of its wilderness, and getting to know your country—its valleys and hills, its forests and plains, its rivers and lakes.



But there is more than adventure in hiking—there is health in it too. Hiking is one of the best exercises known—one of the best ways of developing personal fitness. As you hike, you strengthen your lungs and heart, straighten your back, harden your muscles. Your blood runs tingling through your veins.

And there is fun in hiking. Not the laughing kind of fun, but an inner joy and the primitive happiness that comes from feeling free as a bird, fit and self-reliant, released from the humdrum of your everyday life. No roar of traffic, no jabber from TV sets, no blare from radios, but all around you the small sounds of nature—the singing of birds, the humming of insects, the whispering of the wind in the grass, the rustling of leaves.

Your eyes open wide to your surroundings and to everything that happens—to the scarlet flash of a cardinal, the bounding jump of a deer, the flight of a rabbit across the field.

The whole year is for hiking. Every season should find your patrol and troop on the open road. Then someday you will be a real hiker. But not until you have hiked through the soft breezes of spring, the heat of summer, the showers of autumn, and have felt the bitter wind of winter on your cheeks. Not until you have seen the glory of a spring sunrise, the glow of the harvest moon.

That kind of hiking is not for softies. It is only for fellows who have the guts to face whatever hardships come their way. You won't always have easy going and fair weather. There'll be fights with brambles and thorns, tough climbing over rocky trails, unexpected holes in the swampland, sudden downpours. With the right spirit you will learn to take the hardships with good humor, as part of the joy of hiking. And in overcoming them you will help build yourself into the kind of man you want to be.

YOUR SECOND CLASS HIKES

There's lots of hiking ahead of you in Scouting. Every good patrol and every good troop has an outdoor program that will get you out under the open sky at least once a month. It won't take you long to learn what precautions to take before setting out and how to act on the way to make the hike safe as well as enjoyable.

1 🦋 *Tell what precautions must be taken for safe hiking.*

Precautions for Hiking. To travel safely, the early pioneers had mostly to be prepared against Indians and wild animals. Today, the precautions you have to take are different. Here are some of the more important ones:

The streams of America that were once pure are no longer safe for drinking. So plan to bring water with you in a canteen or carry chemicals for water purification.

You have not been trained from childhood, as the pioneers were, in finding your way. So take along map and compass if you are going into unfamiliar territory.

Unless your feet are already accustomed to long-distance hiking, better put in your pockets a couple of adhesive bandages in case blisters should form on a heel.

For hiking on a road after dark, you need to be plainly visible to motorists. For this, bring along a large, white handkerchief to tie around your leg.

2a 🦋 *Take three hikes, each on a different day, of not less than 5 miles each with your troop, your patrol, an adult, or another Scout who is at least Second Class.*

Taking Your Second Class Hikes. The best possible occasions for taking your Second Class hikes is when your patrol goes hiking and your patrol leader is right there to see how good you are. He will want you to prove yourself a GOOD hiker. So will the other fellows in your patrol. After all, you are a member of the gang—they all want to be proud of you.

It is possible, of course, that your patrol does not have a hike planned at the moments when you are ready for your Second

You may take your Second Class hikes with your troop or your patrol, with a buddy or an adult, such as your father.



Class hikes. Instead of waiting, you can then make an arrangement to take your hikes in some other way—with your buddy if he is already Second Class or better, with one of the troop leaders, or with your own dad if he is an outdoorsman. Whoever goes with you must be approved by your Scoutmaster.

2b 🐿 *Before each of these hikes, submit a hike plan for approval (unless this is a troop hike) to your Scoutmaster or an adult assigned by him.*

Planning Your Hikes. To get the most enjoyment and profit from a hike, you need to do a bit of planning ahead. When will you start? What will be your destination? What route will you follow to get there? What will you do on the way and when you reach your goal? What will you have to eat? When do you expect to get back home?

Your hike may be a morning hike only or an afternoon hike or possibly an all-day outing. Your destination may be a hilltop, a lake, a beach, a historic spot, your favorite campsite. You may want to train in Scoutcraft or learn about nature or go in for exploration or simply hike for the sake of hiking—to roam the forests and the fields, to toughen your body.

Jot the details down. They will form your hike plan and will help you to write up your diary of your hike when it is all over.

YOUR HIKING OUTFIT

In days gone by it was the natives of the world who were the great hikers. The early American Indians, dressed in loincloth, roamed the continent on soft moccasins. The African Zulus and the Australian bushmen hunted their food and their enemies naked and barefooted. But since you are neither a Zulu nor a bushman, you want to be somewhat better outfitted for your hiking. For a successful experience, you need suitable footwear and clothing and adequate equipment and provisions.

2c 🦋 *Before leaving on each of these [three] hikes, present yourself (to your hike leader or companion) for inspection suitably clothed for the locality, season, and weather and equipped for the occasion.*

Footgear for Hiking. Feet that are strong and well cared for are your most important gear for hiking. Keep your feet in shape through daily walking, running, and jumping. Wash them often. Trim your toenails almost straight across rather than rounded. This will prevent the corners from cutting into the skin.

Your hiking shoes should be old friends—fitting correctly, well broken in, and with soft uppers and strong soles. They should have ample room to the front for your toes to spread and to move, but should hug the arch and heel snugly for support and to prevent friction. Official Boy Scout shoes meet these requirements. For most hiking, regular low shoes are good. But in rough



The Scout uniform is excellent for all-year hiking wear.



country ankle-high shoes or hike boots are better. Clean your shoes after a hike and keep the leather pliable with a good polish.

Official Scout socks or stockings—made of cotton and stretch nylon or of wool and stretch nylon—are especially good for hiking. Some hikers like to wear a pair of thin nylon or rayon socks inside their stockings.

Clothed for the Season. Whatever the season, your Scout uniform is your best clothing for hiking.

There are fellows who seem to think that “any old clothes are good enough for hiking.” You know better. Old clothes have a way of binding in the wrong places, because they have been used more for sitting than for walking. They may break at the knees when you try to climb in them and they have a way of ripping when caught by a bramble. Not so your Scout uniform. It is sturdy and comfortable, because it was designed specifically for tough outdoor use.

But there is something else: On a Scout hike you will want to look like a Scout. You will want your whole patrol to look like what it is: an important part of the largest outdoor gang in the world. So it is not only for hike comfort that you wear the Scout uniform, but also to show your pride in being a Scout.

For hot-weather hiking on open roads and across fields, short-sleeved shirt and shorts are perfect. The cut is comfortable and the air around your arms and legs feels cool on your skin. Wear long stockings to protect your legs. Remember that a hot day may be followed by a cool evening. If you expect to be hiking after dark, you may need a jacket or a sweater to be comfortable.

For cool weather and for cross-country hiking through brush and brambles wear long-sleeved shirt and trousers. Have your trouser legs hemmed straight at the bottom, without cuffs—cuffs are a nuisance on a hike: they collect dirt and twigs and weed seeds. To prevent the bottom of the trouser legs from getting muddy on a rainy day or wet when you walk through dewy grass, you may want to slip a pair of leggings over them.

If you expect rain, take a poncho or a raincoat along and possibly rubbers.

For medium-cold weather, you may want to add a Scout jacket or a sweater to your uniform. Because of its loose weave, a sweater will give you more warmth if you wear it *under* your Scout shirt instead of on top of it.

For really cold weather, put on a heavy sweater or wool shirt over your uniform and over that a water-repellent, windproof outer garment. You may also need to wear extra-heavy underwear under your uniform. Remember that several light layers of clothing are better than a couple of heavy ones—the airspace between the layers is excellent insulation against the cold. But also, several layers permit you to shed one or more of them to keep you from getting overheated while hiking. Then when you stop for a rest, you put back on what you took off to prevent getting chilled. On your hands wear knitted mittens inside water-repellent overmittens, and on your feet, hike boots or ski boots.

What about headgear? The Scout cap makes you look snappy. But if you want better protection for your head against sun and rain, the broadbrim Scout hat is your answer. In cold weather, the flaps of the Scout winter cap protect your ears.

Hike Equipment. For every hike there are specific things you want to have in your pockets to be prepared: matches in a water-proof container, piece of string, safety pin, notebook, pencil, a couple of adhesive bandages, knife, handkerchief, toilet paper. If you are not certain of safe water along the way you may decide

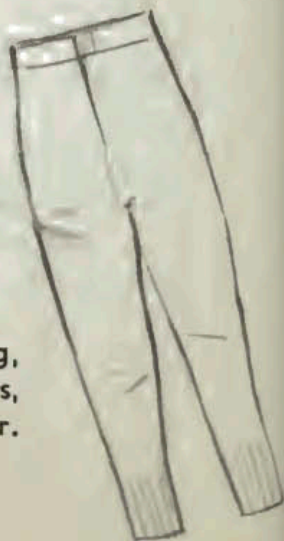

For winter hiking, add outer garments, heavy underwear.



On a rainy-day hike, use poncho or raincoat and possibly rubbers.

to bring a canteenful from home or water-purification tablets to make the water safe where you stop.

For special kinds of hikes, you need special equipment. If you intend to build a fire, you may want a hand ax to prepare firewood—although on most hikes you can get along without one. For a Second Class hike, you won't need any pots or pans—you cook without utensils; but for a patrol hike you may want a cook kit as well as eating gear: fork, knife, spoon. You will require map and compass for an exploration hike and field glasses for a bird hike. For a pioneer hike, you will have to bring ropes and for a photographic hike, cameras and films. Whatever the special program of your patrol hike, someone should carry a first aid kit so that you will be prepared in case of injuries.

Some of this equipment you may already have. If you need to buy it, look for official Boy Scout equipment. It is tested and approved for a successful outdoor experience. It is available at the local store that sells Boy Scout uniforms.

Hike Food. Napoleon said, "An army marches on its stomach." That goes double for a gang of healthy boys. So, in addition to equipment, you'll want to bring grub. This can be a ready prepared luncheon snack to munch when you stop for your noontime rest or foodstuff for cooking.

On a patrol hike, the smart thing is to put all your equipment and food into a single pack and take turns carrying it. On a buddy hike or a hike by yourself, you can get along with a small hike bag swung over one shoulder. Only a green Tenderfoot carries his gear and his food in his hands.



ON THE HIKE

With a general idea of what you want to do and with your hiking outfit in shape, you take to the road with the gang. Your patrol flag waves in the breeze. Everybody's in high spirits.

You'll soon find out what kind of hikers you are.

2d 🦋 *On each of these [three] hikes, observe proper hike precautions.*

Follow Hike Procedures. For a hike to be a success, it should give you a good time and teach you something new. But first and foremost, it should get you safely to your destination and safely home. You can be assured of all of this if you follow proper hike procedures.

What are these hike procedures? They involve the following:

Walking correctly, at a suitable speed, with necessary rests

Proceeding with care cross-country and along roads using simple patrol formations when needed

Following the rules of the land and showing common courtesy

Using safe water only for drinking

Being clean in your personal habits

How To Walk. Imitate the Indian when you walk—he knew how to hike. For his kind of walking, come down lightly on your heel, with your toes pointed straight ahead and push off with your toes. Glide along with a smooth, natural movement of your whole body. Walk everyday, pass up the rides, and walk as

though you have to get somewhere in a hurry. Your own natural hiking pace will come to you as you put the miles behind you on the trail. When you carry a pack, keep the weight high on your back and lean forward with only a slight stoop.

Your Hiking Speed. On a patrol hike you are out to enjoy the trail and the fresh air and to learn Scouting—not to break records. Fit your pace to the purpose of your hike and the distance you intend to go. If you are out looking for animals or birds, you won't be traveling far. But, if you are out exploring, you may want to cover ground. For that kind of hiking, 3 miles an hour is a good average speed and easy enough to keep up if you have learned to walk correctly.

For a long hike, a good test of your speed is the talking test. When you move so fast that your conversation stops, you are just swallowing miles and not getting the patrol fun you should have. Slow down to a pace suitable for all and swing along with a song, if you like, to shorten the trail.

Resting on the Way. Every half hour or so, stop for a rest. Make it short—3 to 5 minutes, seldom more. If you rest longer, your leg muscles stiffen, and you'll have trouble limbering them up again. For a real rest, lie down on the ground with your legs up against a stump or a rock to make the blood run from them. When the minutes are up, get back in your stride.

While hiking, be your age and stay away from candy and pop. They only make you thirsty. So does continual sipping from the water in your canteen. If you feel thirsty, put a small clean pebble in your mouth. It should be large enough so you won't swallow it by accident. You will be surprised at what this does to keep you from feeling thirsty.

You rest by lying down with your feet up against a tree.





Train in the proper way of walking to cover distances without tiring.

Do not step on logs or loose rocks. Step over them—for safety's sake.



Proceed With Care

Safety Cross-Country. Scout hiking is done cross-country or along bypaths—which may not be paths at all but possibly the bank of a river, the shore of a lake, the beach along the ocean, the ridge of a hill, an overgrown trail through the underbrush, or even a compass direction that'll take you straight through the landscape.

When you travel cross-country like this, the big rule is "Watch your step!" It may be fun to jump from rock to rock and to hurdle fallen trees—and you will probably get away with it most of the time. But sometime a rock may be slippery and a log rotten. Then what? A sprained ankle is no fun on a hike.

So put your feet down on solid ground. Don't step on a log—step over it. Don't place your foot on a loose rock—it may throw you. And watch out when you use trees or shrubs for handholds in scaling a slope or swinging yourself down a mountainside—the tree must be sound and the shrub firmly rooted.

Safety on Roads. Although a Scout hike is meant to take you through woods and over fields, you may often have to follow a main road for awhile before you reach a place where a trail leads off to adventure.

Roads nowadays are built for cars—not for hikers. When you use them for hiking, you must look after yourself.

To be safe walking along a road, keep as far over to the left as possible, facing the oncoming traffic. In this way you can see an approaching car and get off the road to let it pass. If there is a shoulder along the side of the road, you are safer here than on the road itself.

For night hiking, tie a white handkerchief flat around your lower right leg. This white signal, bobbing up and down as you walk, can be seen easily in the headlight of a car. Even so, step off the road and let the car pass by.

These rules hold true whether you are alone or with the gang.

In the patrol you should move in single-file formation far over to the left, or, better, completely off the roadway. The patrol leader walks a few steps ahead of the first Scout, the assistant patrol leader a few steps behind the last.

Handkerchief around leg makes it easy for motorist to see you at night.





Arms straight
ahead of you:
PATROL FILE



Arms straight
out to sides:
SINGLE LINE



Arms raised
part-way up:
HALF CIRCLE



Both arms swung part-way up: CIRCLE

Arm swung overhead (left): ASSEMBLE or COME BACK



Silent Signals for Formations and Field Work. Whenever your patrol needs to get into a more or less formal formation—such as for walking along the side of the road—or when you have to move cross-country on a nature expedition or in some exciting Scout game, your patrol leader doesn't give out with a loud shout to tell you how you are to move. Shouting would get people to wonder what kind of noisy gang you are and would scare away any birds or animals or "enemies" you might hope to surprise.

Instead of giving a shouted command to the gang, your patrol leader makes a hand signal. The fellows see it and obey it immediately without a sound.



Raised arm
swung forward:
MOVE FORWARD



Arms swung
to the sides:
SPREAD
OUT



Fist moved
up and down:
HURRY



Flat palm raised high: HALT

Flat palms moved downward (right): TAKE COVER



The signal used most often is the one for "Attention."

In this, the leader raises his right hand high above his head in the Scout sign. Everyone stops talking and whatever he is doing, raises his right hand in the same way and waits for what is to follow.

This may be a signal for getting into formation—such as single file, single line, half circle, or full circle.

Or it may be a signal for some movement in the field such as "Move forward" or "Take cover," "Spread out" or "Come back," "Hurry" or "Halt."

The illustrations show how these silent signals are made.



Let no one say — and say it to your shame



Follow the Rules — Show Courtesy

Obey all “Keep Off,” “Private,” and “No Trespassing” signs. Cross private property only with the owner’s permission. Leave gates the way you found them, and remember that fences are put up to keep somebody out or something in—not for climbing.

Nothing in the world makes it right for anyone to cross a planted field or a meadow before it is mowed. To do this is to damage a farmer’s crop. Woodlands are crops, too. You are interested in conserving them, not in marring or destroying them.

Domestic animals are someone’s property. Cows give more milk when left in peace. Horses are in the field to rest. Scouts do not molest them.

Walking on railroad tracks and trestles is not only against the law, but extremely dangerous. Stay off!

Hitchhiking is out! It isn’t hiking at all! And furthermore, it may be unlawful in your State.

If you stop someplace to cook, be sure you have permission to light a fire. In many places, a written fire permit is required. After eating, check the grounds carefully. Leave them in such condition that no one can see that you were there.



that all was beauty here until you came.



Safe Water for Drinking

When it comes to drinking on a hike: Drink safe water only.

The water you carry in a canteen from home is safe—but you can't be sure of the water from a spring or a stream. Even crystal-clear brook water may contain dangerous germs. Some States mark pure roadside springs with signs that say "Safe Drinking Water."

If you are not certain of your water, make it safe for drinking by killing the germs in it by one of these methods: The best method is to boil the water for 5 minutes, then pour it back and forth from one clean pot to another, putting air back into it. This cools it and improves the flat taste of boiled water. *Or* dissolve two chlorine water-purification tablets or one iodine water-purification tablet in 1 quart of water and let it stand for 30 minutes before using, stirring from time to time. *Or* add 3 drops of 2 percent tincture of iodine to 1 quart of water, stir well, then let stand for 30 minutes.

Personal Cleanliness. If you need "to go to the bathroom," make a one-man latrine by scooping a "cat hole" in the ground with the back of a heel. After using, push the dirt back in.

FIND YOUR WAY

Where are you going on your hike? Out? Well, you want to be a bit more definite than that. You want to know what route to take, your destination, and what to do when you get there.

If you have already done some hiking with your dad or with a buddy, you probably know most of the favorite outdoor spots nearby and can find your way to them and back again.

But for real Scouting fun and excitement with the gang, you'll want to travel farther afield. You want to feel yourself akin to the scouts of old—the Indian, the pioneer, the guide, the tracker, the explorer, the men who traveled across America.

In those early days, finding the way was a task for an expert. He had to be able to remember every important landmark he passed so that he could recognize it later—every peculiar rock formation, every river he crossed, every mountain ridge that rose in the distance, every deer run or buffalo path he followed. He had to figure out directions from the sun in the daytime and the stars at night, from the point from which the winds blew, from the way a free-standing tree leaned away from the prevailing storms.

Today it is an easy job to find your way with a good map and a dependable compass. On a map you can locate the spots that are worth exploring and can lay out your routes to them along highways and byways. And for traveling cross-country off the beaten track, your compass will lead the way.

YOUR HIKE MAP

A map is simply a picture of a piece of land as it would look from the air—the way you would see it if you were flying above it in a plane. Looking down, you would see roads and rivers, fields and forests, villages and towns. On a map the most important of these details are shown by special signs—map symbols.

You are already familiar with many kinds of maps—the maps in your schoolroom of the whole United States and of the world, the automobile road maps your father uses when driving. But none of these maps is of any use for hiking. They cover too great distances and show too few details.

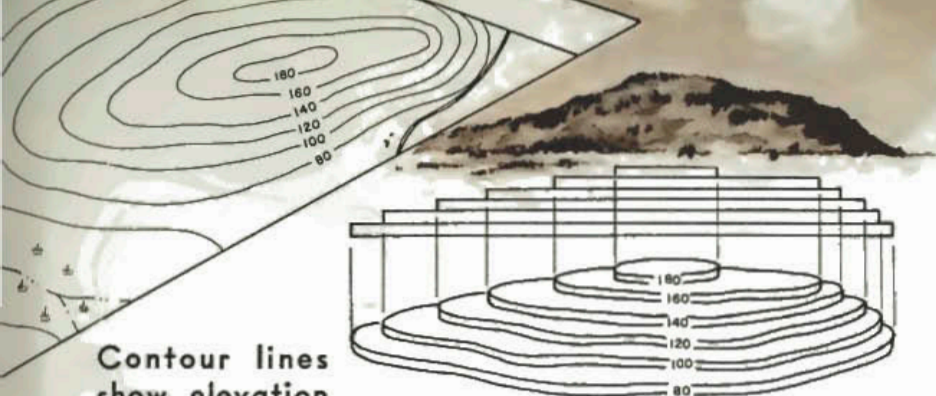

Contour lines show elevation above sea level.

The kind of map you need is the kind produced by the U.S. Geological Survey. It is called a topographic map—from the Greek *topos*, place, and *graphein*, to write or draw.

Topographic maps come in many different scales. The scale is the relation between a measurement from one point to another on the map and the actual measurement between those same two points in the field. A good scale for a hike map is the scale of 1 inch to 24,000 inches—or, as it appears on the map, 1:24000. A distance of 1 inch on this kind of map means a distance of 2,000 feet in the field.

Getting a Map. To get a topographic map of your hiking territory, first send a postcard to Map Information Office, United States Geological Survey, General Services Building, 18th and F Streets NW., Washington, D.C. 20405, and request a free *Topographic Map Index Circular* of the State you expect to hike in and a free folder describing topographic maps.

The index circular is a small map of the State divided into sections called “quadrangles.” Each quadrangle is a separate map. Find out which quadrangle covers your hiking area. Then order the map by giving the name of the quadrangle and including a money order or check for 50 cents in payment. Send order for map of area east of the Mississippi River to Geological Survey, Washington, D.C. 20405; for map of area west of the river to Geological Survey, Federal Center, Denver, Colorado.

It is possible that your State has developed maps for your particular area. Drop a line to your State capital for information.

3 🐾 *Identify on a topographic map at least 10 different map symbols including contour lines.*



Open pit, mine	✕
Index contour	
Intermediate contour	
Fill	
Cut	
Power line	-----
Telephone line, etc.	-----
Railroad	
Hard surface roads	
Improved road	
Unimproved road	-----
Trail	-----
Bridge	
Footbridge	-----
Perennial streams	
Water well - Spring	o ~
Lake	
Marsh (swamp)	
Buildings (dwelling)	
School - Church - Cemetery	
Buildings (barn, etc.)	
Sand area	
Woods	
Orchard	
Crude	

Studying the Map. Spread out the topographic map in front of you. Study it carefully. Try to find all the map symbols it contains.

Everything printed in *black* is the work of man—roads, railroads, cities, bridges, boundaries, names. Take those black lines—they are roads. A good road is shown with two solid lines, a poor one by two broken lines, a path with a single broken line. A railroad is one or more lines with many short crosslines to suggest the railroad ties. Black rectangles are buildings. If a rectangle is topped by a cross you'll know it's a church. If it is topped by a tiny flag it's a schoolhouse.

Anything *blue* is water, of course. A blue line is a brook, a blue band a river, a blue blotch, a lake.

Woodland areas are printed in *green*.

Hills and valleys are indicated by *brown* lines. These lines are called "contour lines." Every point along one of these lines is the same number of feet above sea level. Follow one of the heavier brown lines on your map, and you will come upon a number—for instance, 100. Everything on that line lies 100 feet above sea level. The contour lines tell you the ups and downs of the countryside. Where the lines are far apart, the ground is gently sloping—it may be suitable for a campsite. Where the lines are close together, the hill is steep—hiking may be tough. If the lines fall together, they show a cliff. The top of a hill may be indicated by a number. This number is to the height of the hill in feet at its highest point.

YOUR COMPASS AND HOW IT WORKS

But maybe you don't want to follow roads or trails. Maybe you want to travel right smack through the countryside. For that kind of traveling, you'll need a compass.

4a  *Explain how a compass works. Give its eight principal points.*

How a Compass Works. The important part of a compass is a magnetized needle, balanced on a pinpoint, free to swing around. When the needle is left to itself, it eventually comes to rest, always pointing in one certain direction. The reason for this is that there is a force in the earth that pulls at the needle—the whole earth is like a tremendous magnet with one magnetic pole in the north, the other in the south.

The earth's magnetism makes one end of the compass needle point toward magnetic north. This end is clearly marked as the north end. It is either painted (black or red) or stamped with the initial N or shaped like an arrowhead.

The Compass Points. When you know where north is from looking at the compass needle, you should have no difficulty finding the principal points of the compass: Face north. South is then directly behind you, west on your left, east on your right. Halfway between north and east is northeast; halfway between east and south is southeast; halfway between south and west is southwest; halfway between north and west is northwest. Or, starting from north and going clockwise: north, northeast, east, southeast, south, southwest, west, northwest, and back to north again.

In the old days when a boy went to sea to become a sailor, he had to learn those eight compass points and the points in between, and the points in between those again, before he was taught how to steer a ship. The names of those in-between points got quite complicated. Fortunately, someone finally suggested the use of the 360° of a regular circle instead of names. So nowadays, a sailor takes his directions or "bearings" by degree number instead of by names. But he may still say that a wind is southwesterly (blowing from southwest) or that a storm is "a real northeaster" (blowing from northeast).

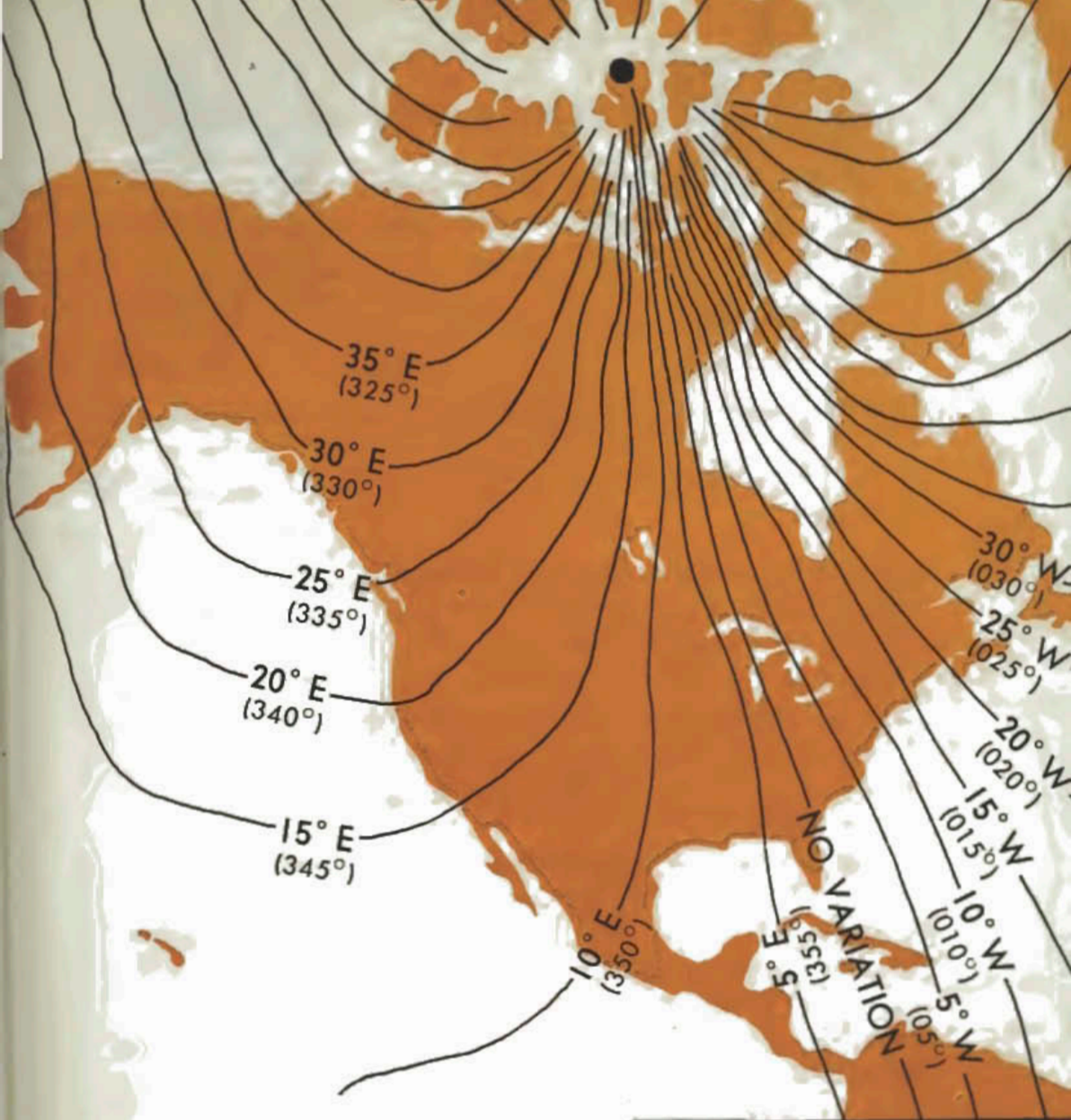

True north is the map direction toward the North Pole. Magnetic north is the compass direction toward the magnetic north pole. The mariner's compass shown here points to the magnetic North Pole. The difference between the magnetic north and true north is called "compass variation." Your compass on land may point up to as much as 20° west of true north in parts of Maine; up to 30° east of true north in eastern Alaska. The rest of the United States lies between these variation extremes. The number in parentheses is the true north compass reading on that line.





Read compass bearing by pointing to landmark and setting compass.

4b  Set a compass and use it to read at least three bearings in degrees.

Reading a Compass Bearing in the Field. Let's say you want to read a compass bearing in the field—that is, you want to find the direction to a certain point expressed in degrees.

You face squarely the landmark toward which you want to know the bearing and hold the Pathfinder compass level in front of you, at waist height or a little higher, with the direction-of-travel arrow of the baseplate pointing straight ahead of you toward the landmark.

Now twist the compass housing until the compass needle lies over the orienting arrow that is printed on the inside bottom of the housing with the north part of the needle pointing to the letter *N* (north) on top of the housing. Read the number on the outside rim of the compass housing at the spot where the direction-of-travel line touches the housing, and you have the bearing in compass degrees.

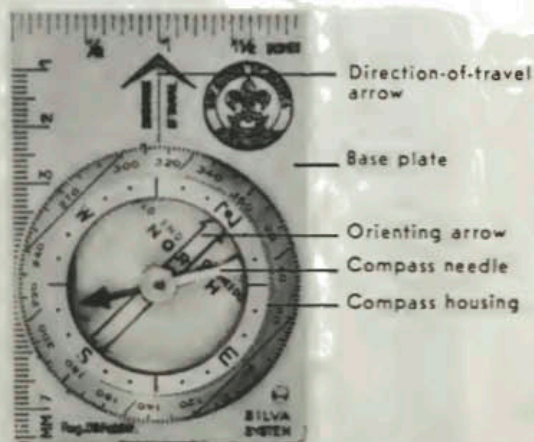

The official Pathfinder compass is especially good for Scout hiking. It is more than a compass—the box that houses the compass needle is attached to a baseplate that acts as a direction pointer, a tool for taking bearings, and a ruler for measuring map distances. The Explorer III with its liquid-filled housing is even easier to read.

Using Map and Compass Together

Well now that you have your map and know how to read the symbols on it and have your compass and know how it works, it's time to take them along on a hike and make use of them.

But before you set out, decide where you want to go. Spread out the map and look at it. Plan to start from a point familiar to you—such as a road crossing or a bridge or a prominent building. Next, decide on a good destination—a hilltop, a lakeshore, a forest. Finally, lay out on the map the legs of a route that will take you from your starting point to your destination.

5a 🐾 *Show how to orient a map.*

Orienting a Map. Ready now? You are at your starting point rarin' to go! But in what direction? If you are at a road crossing, for instance, do you go straight ahead or to the left or to the right or backward? You will know as soon as you have "oriented" your map. To orient a map means to line up all the directions on it with the same directions in the landscape.

So study your surroundings for some prominent landmark that will be shown on your map—a hill or a building or a bridge. Inspect your map and find the map symbol for the landmark on it. Then turn the map until the line from the spot on the map where you are standing to the map symbol that indicates the landmark lies in the same direction as the line from your actual

Map is oriented when map symbols fit the actual features in the field.



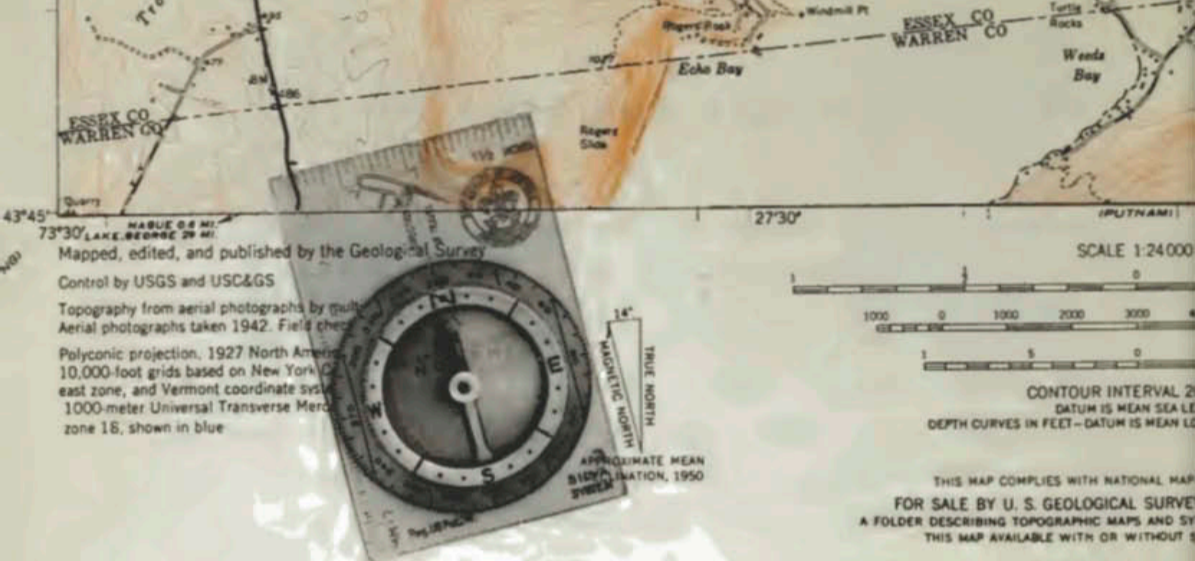

position to the actual landmark. You have now oriented your map “by inspection.”

You can also orient a map “by compass.” To do this, first find the half arrow in the bottom margin of your map that indicates magnetic north. Place your Pathfinder compass next to this half arrow, with the edge of the baseplate parallel with the arrow line, as shown above. Turn the map with the compass lying on it until the north part of the compass needle points in the same direction as the half arrow on the map.

5b 🦋 *Use a map (preferably a topographic map) and a compass to follow, far enough to prove your ability, a route indicated on the map.*

Cross-Country With Map and Compass. The method of orienting your map with or without a compass and using the oriented map for finding your way works all right when you lay your route along roads and highways, but it isn’t very satisfactory when you want to travel cross-country, off the beaten track. Here the proper method is to set your compass from the map for the correct direction of each leg of your route in turn and to depend on the compass with the direction set on it to take you from one point to the next.

Now, in using map and compass together, you must always keep in mind that map directions are based on *true north* and

compass directions on *magnetic north*. On a topographic map a line drawn from a mark at the bottom of the map to the corresponding mark at the top points toward the real North Pole. The north part of the compass needle, on the other hand, points in the general direction of the magnetic North Pole, as shown on page 131. The simplest way to overcome the difference between these two directions is to arrange for the map to agree with the compass at all times by providing it with magnetic north-south lines. To do this, locate the magnetic north half arrow in the bottom margin of your topographic map and draw a continuation of the half arrow line up through the map. Then draw several other lines parallel with this line one ruler width apart. See the map below and the map on page 136.

With the map outfitted with magnetic north-south lines, you use map and compass together by following the three steps described on page 136. After practicing a number of times this method of setting the compass to directions on the map, you are ready for a cross-country journey.

Lay out a route on your topographic map connecting five or six clearly indicated landmarks: road forks, buildings, hilltops, and the like. Set the compass for the direction from your starting point toward the first landmark and get going. When you reach that first landmark and have thus completed the first leg of the route, reset the compass for the next leg toward the next landmark and continue in this manner until you have covered the complete route and have reached your final destination.

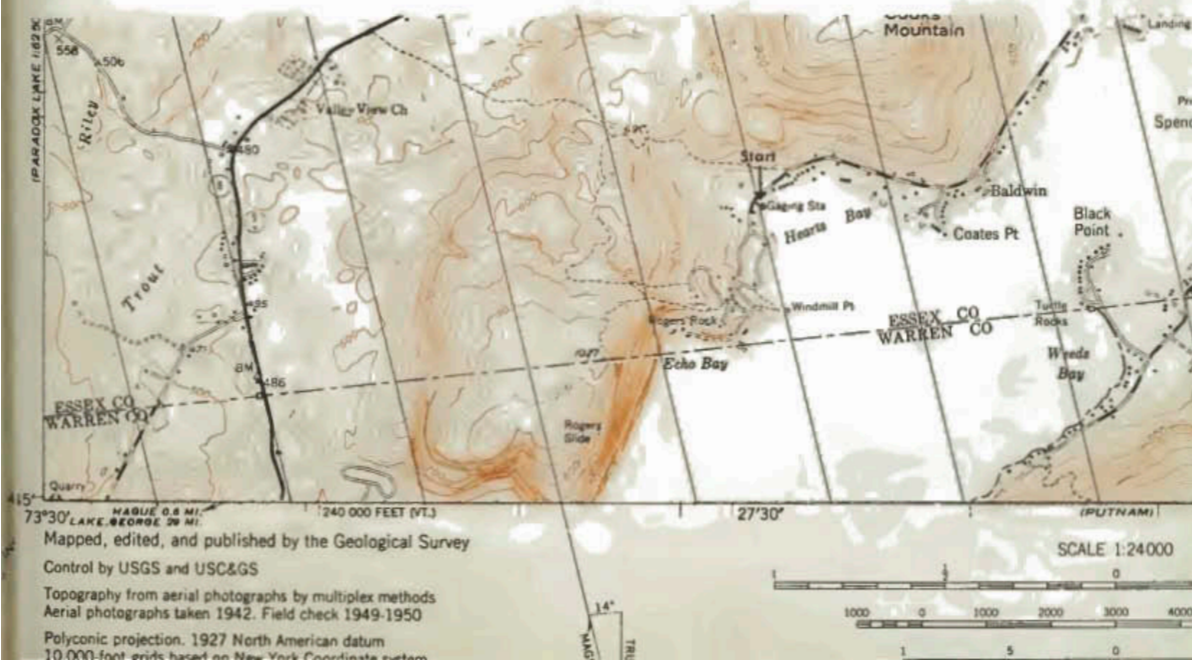

Using Map and Compass

Step 1—On the map, line up the edge of compass with your route. Place Pathfinder compass on map so that the edge of its baseplate touches both your starting point and your destination, with the baseplate's direction-of-travel arrow pointing in the direction you want to go. Look at the map.

Step 2—On the compass, set the housing to the direction of your route. Hold baseplate firmly on the map. Paying no attention to the needle, turn the compass housing until the north arrow on the bottom of it is parallel with a north-south magnetic line drawn on your map, north to the top.

Step 3—In the field, follow direction set on the compass. Hold compass in front of you with direction-of-travel arrow pointing straight ahead. Turn yourself until north part of compass needle covers north arrow on bottom of compass housing. The direction-of-travel arrow now points at your destination. Pick a landmark in that direction and walk to it, then another landmark.



LOST

The story goes that someone asked Daniel Boone, "Were you ever lost?" Dan thought it over for awhile, then replied, "No, I was never lost. But once I was a mite bewildered for 5 days." Dan was right. No person is really lost if he knows how to find his way.

It would be pretty silly for a Boy Scout to get lost. After all, a Scout is supposed to know how to find his way. But even with a lot of outdoor knowledge, someday you may find yourself "a mite bewildered." It is important for you to know how to act in such a situation.

6a 🦋 *Explain how to keep from getting lost.*

Using Scouting Skills. Tell others where you are going and when you expect to return. Study the hiking area and carry a map of the section with you. Is there a road along one side? If there is, use the road as a base line or catching landmark. Suppose there is a hill in the distance that you wish to explore. Let's say the hill is to the east and the road runs north and south. Use your compass to be sure that's right. OK? Now when you reach the hill, what direction will you hike to return to the road?

Be alert. Notice unusual trees, bushes, plants, and rock formations as you travel toward the hill. Look back to see how these landmarks will appear on your return trip.

6b 🦋 *Explain what you would do if you did become lost.*

Lost by Yourself. If you are on a hike by yourself and get lost, the main thing is to be *calm*. Take it easy. Sit down. Then reason your way out.

In your mind, trace your course back to the point where you definitely knew where you were. "What did I do wrong? Where did I get off the trail?" Recall other hikes you have taken through the same territory and try to remember the features of a map you may have seen of it. "How do the roads run, the railroad, the ridges? Am I north or south, east or west of camp? In what direction is there a catching landmark—such as a river or a lake—that will lead me back to camp?" If there is a lookout point nearby, use it for checking your surroundings.

After having threshed everything out unhurriedly, decide on the most sensible direction to take. Then set out.

If you have a compass, it will be easy for you to hold your course. If you have no compass but the sun is out, you can determine the directions of the main compass points with the help of the shadowless shadow-stick method described on page 139.

Now follow a beeline in the specific direction you have decided on: Line up two landmarks straight ahead of you—trees, rocks, or whatnot—and go to the first one. Here line up a third landmark straight ahead of the second one and proceed again. Continue in this way, always keeping two landmarks in a straight line in front of you. Unless you use a method such as this, you may find yourself running around in a circle.

Eventually you will find some familiar spot or reach a trail or a stream that will bring you back to camp.

Strayed From the Gang. But if you ever become separated from your friends on a wilderness expedition, the thing to do is for you to let *them* find *you*, rather than for *you* to attempt to find *them*.

As soon as your absence is noted, someone will start looking for you, and the best way to help the searchers is for you to stay put and have faith that someone will find you and get you out. Prayer will help. Outside of that, simply make yourself as comfortable as possible and wait.

To assist the searchers, try to let them know where you are. The universal distress call is some kind of signal repeated three

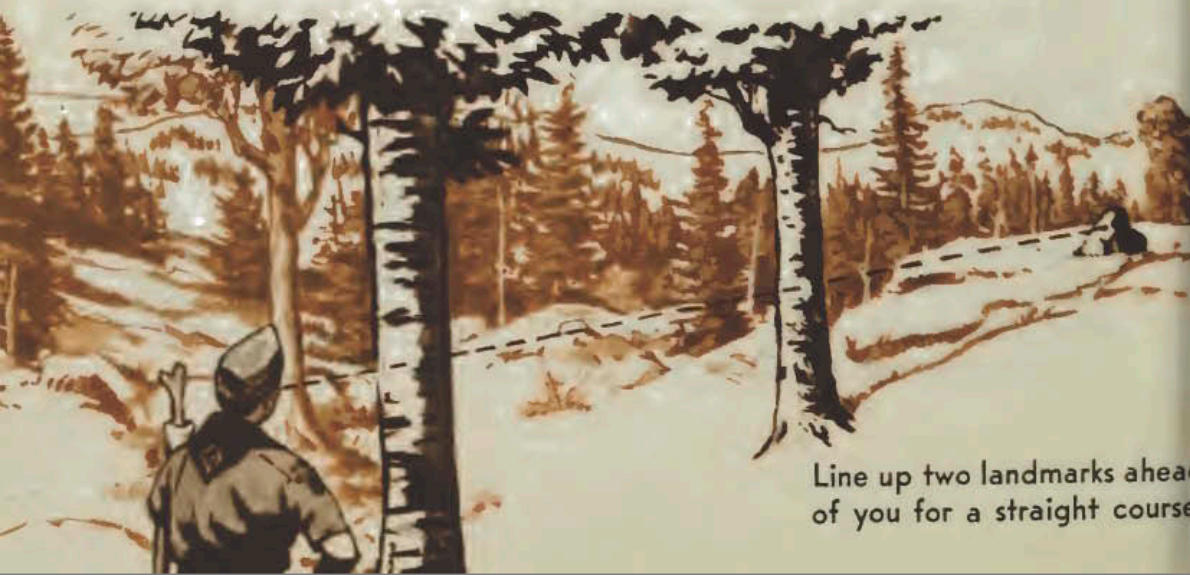

Line up two landmarks ahead of you for a straight course

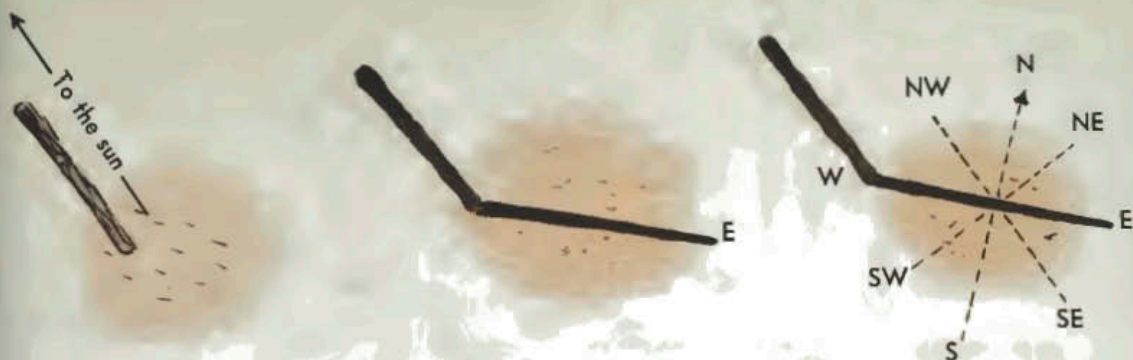

SHADOWLESS SHADOW-STICK METHOD for finding compass-point directions: Push a straight stick into the ground in such a way that it does not cast a shadow—that is, so that it points directly at the sun. Wait until the stick makes a shadow 6 inches long or longer. The shadow forms the west-east line with west at the stick and east at the shadow tip. From this line you can figure other directions. This method is quite exact in the middle of the day and exact enough for your purpose the rest of the time. Study the drawings on this page.

times, at frequent intervals. Three shouts, for instance. Or three blasts with a whistle. Or three columns of smoke. To make such a smoke signal, clear the ground for a safe distance, build three small fires, and make them smoke by throwing grass or leaves on them. The three fires should be at least 6 feet apart to make three separate smoke columns. This signal will soon be spotted—possibly from a fire tower or some other lookout—and the three smoke columns will proclaim that here is a hiker in distress rather than a camper at his ordinary fire. When the searchers have heard you or have spotted you, they will answer you by an OK signal of two shouts or two whistle blasts, or two gunshots.

If you doubt that you will be found before nightfall, collect firewood to last through the night and put up some kind of shelter. Make a framework of branches, cover it with leafy boughs or sprays from an evergreen, then bed down in piles of dead leaves or dry grass. If you need to leave your base to look for food or water, mark the trail with broken branches so you can find your way back.

But whatever you do—*stay put*.

Even better: Learn your pathfinding skills so well that you will keep yourself from ever getting lost.



GET TO KNOW NATURE

When you're out hiking, you breathe the fresh air, smell the good earth. Ahead of you stretches a whole day of adventure.

Now what kind of time will you have?

It depends largely on how well you have trained yourself to make use of your senses.

Some fellows get very little out of life. They have eyes for seeing—but notice nothing. They have ears for hearing—but what they hear goes in one ear and out the other. They have as many little gray brain cells as you have—but their minds remain empty because they have no curiosity, no power of concentration, no ability to store what they learn.

Not you! Your eyes and ears are keen, your mind full of questions you want to have answered. You want to know all about the world in which you live. And you are not satisfied with finding out about the “What is it?”, you want to know the “Why is it?” as well. Not just “What tree is that?” but also “Why does it grow where it grows?” Not just “Which animal is that?” but “Why does it live where it lives?”

Practice Does It. On a patrol hike, there's nothing like a game of FAR AND NEAR to help you become observant. For this,



the patrol leader makes a list of about 20 things worth looking and listening for with a number of points for each, such as:

Barn swallow	2 points	Oriole's nest	10 points
Deer track	5 points	Squirrel	5 points
Garter snake	10 points		and so on

The first Scout observing one of these things reports to the patrol leader and scores the number of points agreed on. The winner is the fellow with the largest score at the end of the hike.

But maybe your patrol doesn't even need a game to get the boys excited about what they see and hear. Maybe you're the kind of gang where everyone is naturally interested in everything about him and wants the rest of the fellows to share his interest. In that kind of patrol you will never have a dull moment.

7a 🐿 *Identify local plants that may cause skin poisoning.*

Poison Plants. On all your hikes, be on the lookout for plants that cause skin poisoning. The most common of these plants is poison ivy (or poison oak if it has oaklike leaves), which may be found almost anywhere, and poison sumac, which you may come upon if you hike through wet swampland.

It is not much fun to come home from a hike with a bad case of itching—or even blistering—from having touched these plants. To

avoid this, you must know how they look. So study the pictures below so that you'll recognize the plants when you see them.

7b 🐦 Find in the field 10 different kinds of wildlife (mammals, birds, reptiles, amphibians, fish, insects) or evidence of them. Tell what they are, describe the natural surroundings where each was found, and explain how this wildlife depends on plants.

Communities of Nature. On your hikes you'll discover an important fact which the Indians knew long before the first settlers arrived: that plants and animals live together in well-defined areas such as forests, prairies, swamps, or deserts; that, if you want to find certain animals, you must go where they live—to a forest for deer, a marsh for ducks, a cool stream for trout.

It will help you understand what goes on in these areas if you think of each of them as a community of nature not too different from the community of human beings in which you live.

Plant life varies from community to community. Some plants like the ground hot and dry and get along in the desert where other plants would die from lack of water and exposure to the blazing sun. Other plants like to keep their "feet" wet and sink their roots into the boggy soil of marshes and swamps. Some plants prefer the bright sunlight of open fields, others the deep shade of dense woods.

It is mostly the plant life that determines what kind of animals



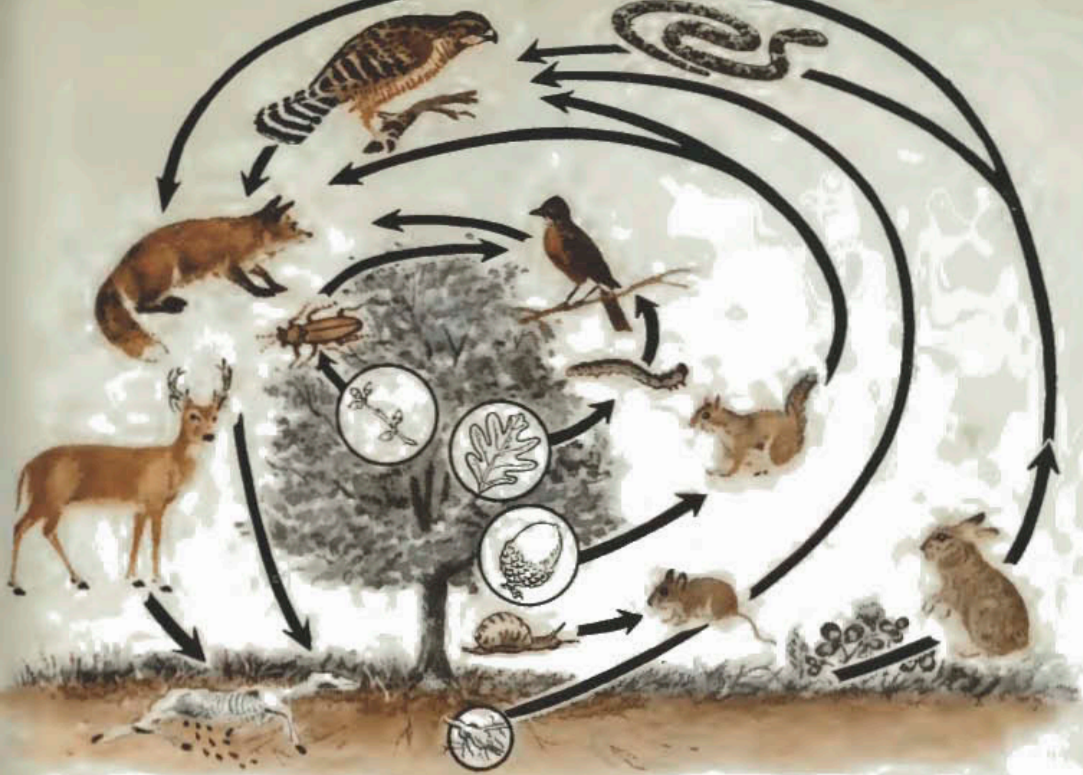

All animal life depends on plant life — directly or indirectly.

live in a nature community. Just as plants require certain living conditions, so do animals have their individual needs. For some animals, these needs are best taken care of in the forest, for others in the field, for still others in the marsh.

Plant life and wildlife go together. All animal life, from the tiniest insect to the largest bear, depends on plants for food. Even the animals that live on flesh alone depend on plants for food—not directly, but indirectly, because the smaller animals they feed on are plant eaters. But in addition to food, plants are important to animals for other reasons. Plants provide cover for escape from enemies, shelter against heat and cold, protection for raising the young.

As you explore a nature community looking for wildlife—mammals, birds, reptiles, or fish—keep your eyes wide open. Some animals you may never actually see—many of them come out at night only or hide in the ground—but you may find evidence of them: tracks, droppings, signs of feeding, scratch marks on trees, dens or nests, skulls, bones, feathers. Many birds give evidence of their presence by their song, although you may not catch sight of them. And how about a certain smell that may

reach your nostrils on a night hike? You don't have to see a skunk to know that one is nearby.

Nature Forever Changing. When you hike through the countryside you'll see numerous changes being made around you. New roads are being built. Dams are being put up to create lakes, marshes are being drained to make dry land. Whenever man changes the landscape, plant life and wildlife soon change as well.

But in addition to man-made changes, nature goes on changing all the time by herself. When you look at any piece of land, untouched by man, it may seem as if nothing is happening to it. But in reality you are looking at a slow-slow motion picture. The changes may not be noticeable in 10 years or a hundred, but changes are taking place just the same.

A shallow lake may be filling up with silt washed into it from eroding hillsides. Grasses and sedges get a chance to move out from the old shoreline. In decaying they build up the soil. Rushes and cattails take hold. They in turn prepare the soil for field grasses and various weeds. Low bushes may get a start—then taller bushes and small trees. Eventually the soil may be suitable for larger trees and, in the end, for a stand of magnificent trees in what is called a climax forest—provided, of course, that the climate is right and that nature has had her own way with the spot, for man, in one day, can undo what nature has created over hundreds or even thousands of years.

Trying to understand the changes that go on in nature is one of the most interesting things you can do on a hike. When you know how to observe, every hike becomes an exciting adventure.

A lake, over hundreds or even thousands of years, may fill up and turn into climax forest.

Succession of plant life as a lake turns into forest. From left: Lake with submerged plants; grasses and sedges; rushes and cat-tails; weeds; shrubs; small trees; large trees.

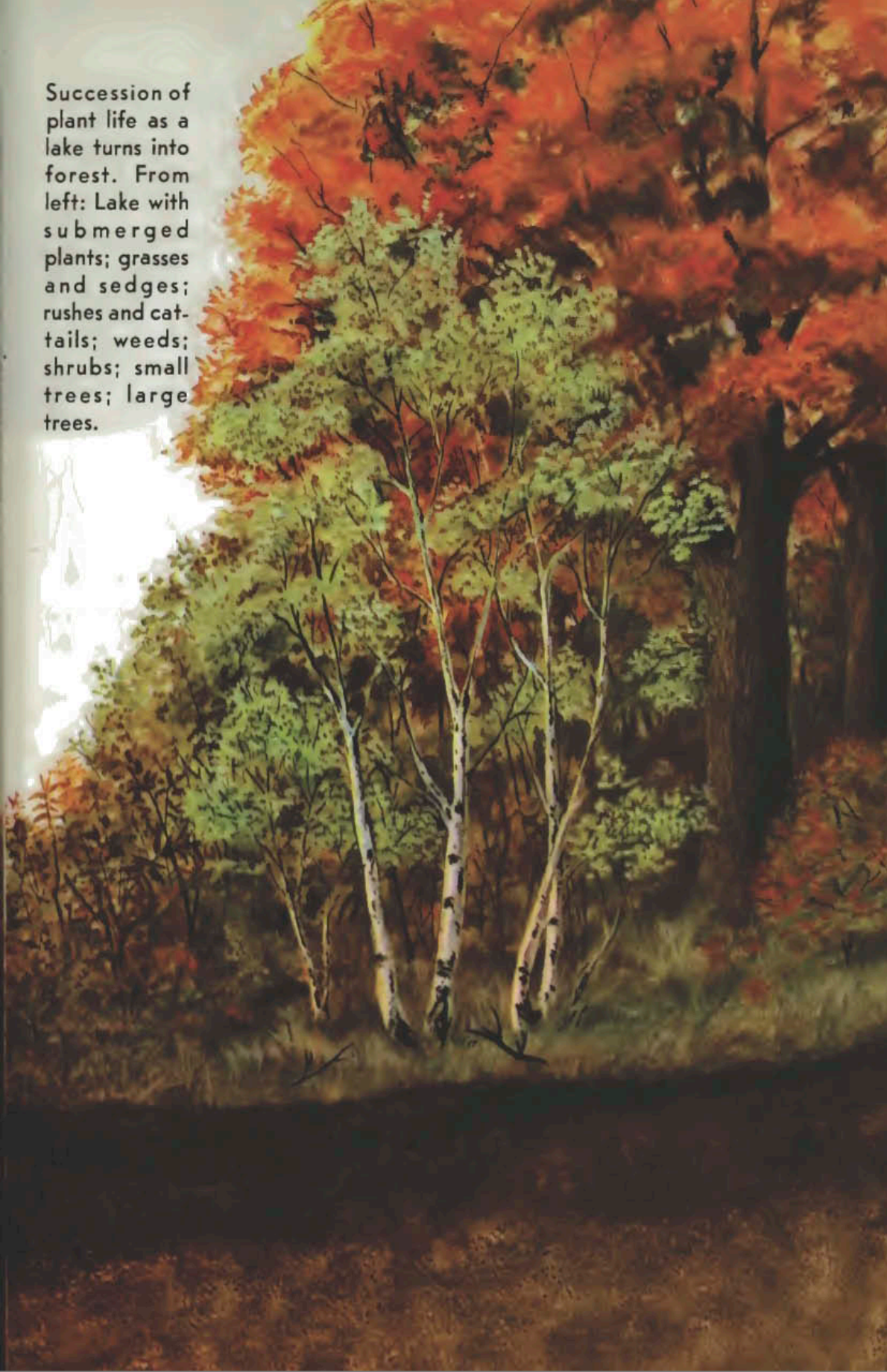



Gray squirrel Cottonwood Song sparrow Scarlet tanager

Fields and Prairies. In most parts of the country, it won't be many miles out of town before you see farms, fields, or prairie.

In the East, these open areas were once great forests—if farming stopped, they would turn back into woodland. On the Central Plains, the areas were prairie—if they were no longer farmed, grazed, or mowed, they would again become prairie. In parts of the Southwest, irrigation has turned desert into fields—if the water should stop flowing, desert would again take over. But there is little chance that these lands will ever return to what they were—America needs her farms to feed her growing population.

Grasses of one sort or another—wild or cultivated—are the chief plants of fields and prairies, and the animals you'll find are those that live in high grass or low shrubbery.

As you walk along a wheatfield or cornfield, you may see a

146

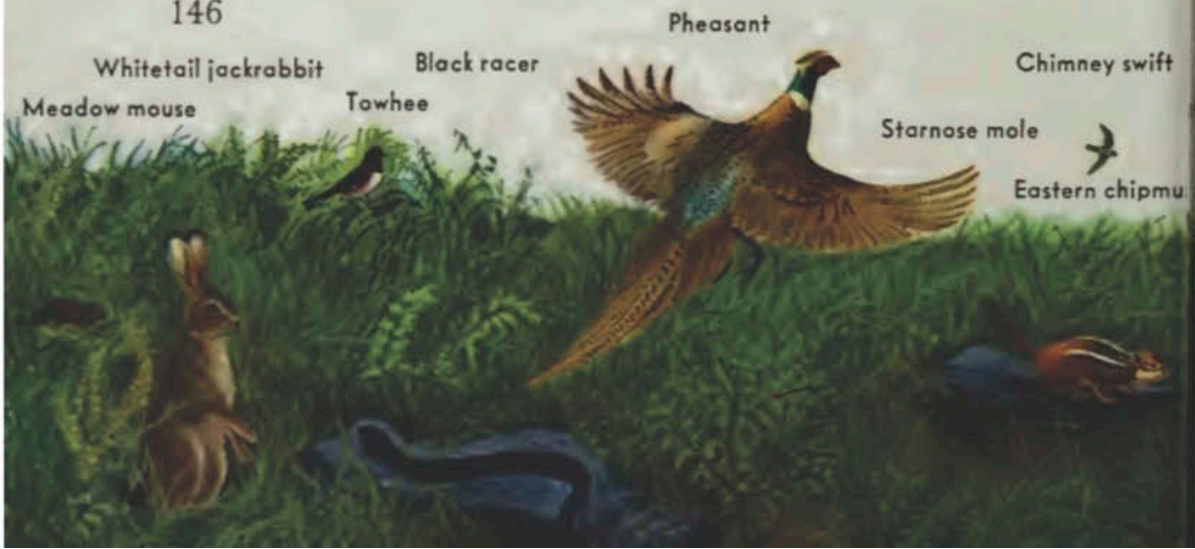

Whitetail jackrabbit

Black racer

Pheasant

Chimney swift

Meadow mouse

Towhee

Star-nosed mole

Eastern chipmunk



Red maple

Crow

Turkey vulture

Robin

meadow mouse scurry in among the stalks and disappear. A moment later, its mortal enemy—a black racer snake—slithers in after it. A woodchuck scampers across your path. A slender chipmunk disappears in a stone pile. A cottontail runs off.

You follow the hedgerow between two fields. Plenty of wildlife here. Different kinds of sparrows flit in and out, towhees rustle up the dry leaves—and suddenly a pheasant takes flight.

That's the kind of experience you may have around farms and fields in almost any part of the country. But each section may have additional excitement. In the East, a red fox may lurk in the bushes. On the Great Plains, coyotes may tune up for an evening concert. In the West, ground squirrels or prairie dogs may look at you from their holes, and you may see in the distance the dashing form of a pronghorn antelope.

147

Shadow lark

Woodchuck

Striped skunk

Indigo bunting

Red fox

Eastern cottontail





Mink

Bank swallows

Marshes and Swamps. Marsh or swamp—what’s the difference? Generally speaking, a marsh is a wet lowland overgrown with cattails, sedges, and numerous kinds of grasses, while a swamp is wetland dominated by shrubs and trees, such as cypress or tamarack. Water is what makes an area a marsh or swamp. The amount of water, soil, and climate determine what plants will grow there—and thereby the wildlife you can expect to find.

The marsh you explore today probably was once a lake or pond. The swamp may also have been a lake—or it may have been woodland which, for one reason or another, overflowed with water. Marsh and swamp are both in-between stages in nature’s ceaseless changing. They may turn into dry fields someday. The process is slow—but is often speeded up by drainage.

Ready to go “bog trotting”? You may get your feet wet hiking

148

Painted turtle

American toad

Spotted turtle

Muskrat

Pied-billed grebes





Pintail

Mallards

Reeds

Marsh hawk

Black-crowned night heron

along the edge of a marsh or swamp—but you'll have lots of fun. In a Northern or Western marsh, you are almost certain to see ducks—here are the nesting grounds of mallards, pintails, black ducks, teal, and others. In a swamp in the South, you'll come upon herons and egrets and others of our spectacular waders.

All around you, you hear the calls and songs of birds—the twitter of swallows skitting over the water, the gurgle of red-winged blackbirds, the singing of warblers, the quack of ducks—maybe the “pump” of the bittern and the “clack” of the rail.

As you walk along the spongy edge, you'll hear the plop of frogs jumping into the water. The sleek brown body of a mink vanishes with hardly a splash. Right at your feet you may come upon the remains of crayfish where a raccoon feasted last night. And out in the water you may spot a swimming muskrat.

Painted water snake

Cattails

Eastern green heron

Red-winged blackbird

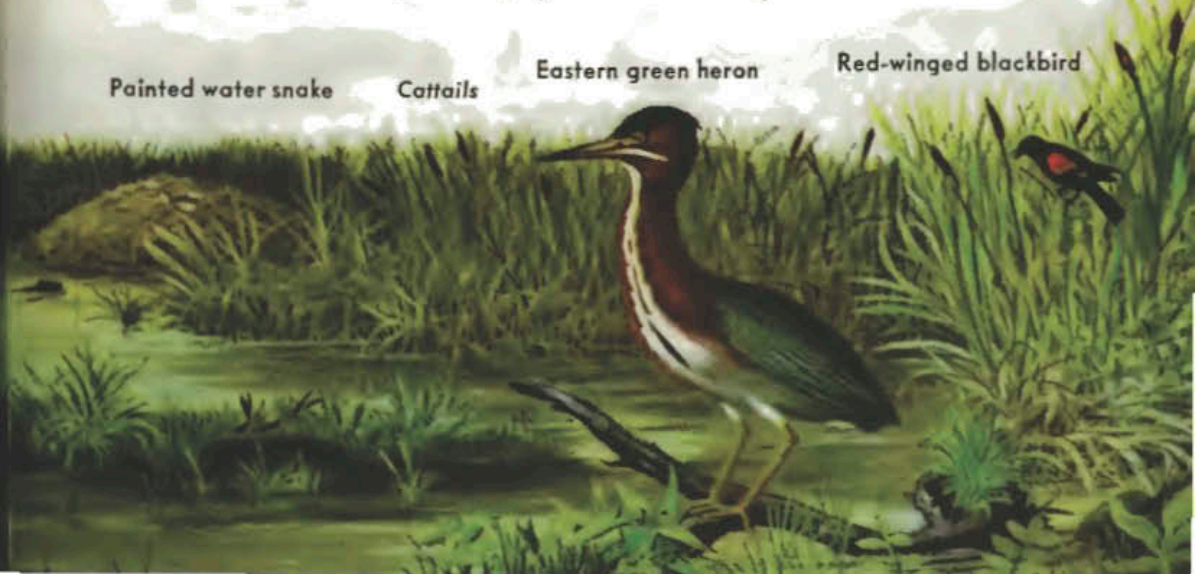



Eastern white pine

Whitetail deer

White ash

White oak Hairy woodpecker

Eastern Woodlands. For real Scouting enjoyment, we “take to the woods.” If you live in the East, those woods will consist mostly of broad-leaved hardwood trees thriving because of the soil, the rainfall, and the moderate year-round temperatures. In the Northeast where the winters are more severe, conifers mix in with the hardwoods. In the humid South, sandy soils, fires, and cattle grazing may keep down the hardwoods—and pines take over.

If the forest should be destroyed by fire or by cutting, it would slowly return to what it was if left alone. Grasses, weeds, and brambles would move in over the burned-over area, then poplar—until the soil is once more suitable for maple or oak or hickory.

You’ll have plenty of excitement hiking through an Eastern hardwood forest any time of the year.

In the spring, flowers of many colors cover the forest floor.

150

Raccoon

Longtail weasel

Box turtle

Wood thrush





Sassafras

Beech

Blue jay

Sugar maple

Then dogwood trees put on their white display, redbuds open up their pink flowers, and spicebushes their yellow ones. Within a couple of weeks you walk through the woods under a green roof.

In the summer, the forest teems with wildlife. From afar comes the steady hammering of a woodpecker, the scolding of a jay, the cawing of a crow. A deer breaks through the underbrush. A gray squirrel jumps from branch to branch overhead.

It is along the forest edge that you'll see most of the forest's birdlife. Red-eyed vireos and redstarts, tanagers and grosbeaks, veeries and wood thrushes and warblers galore play hide-and-seek in the tangle of wild grape and bittersweet.

With the coming of fall, the leaves of the trees turn from green into scarlet and yellow and brown. The leaves fall—and the trees stretch their naked branches toward the winter sky.

Ovenbird

Red eft

Ruffed grouse

151

Ringneck snake





Douglas fir

Red squirrel

Western white pine

Elk

The Evergreen Forest. Along the border of Canada from Maine to Minnesota and westward from Montana to the Pacific stretch dense forests of spruce and balsam and pine and hemlock—poking an arm southward along the Appalachians, an even broader arm down over the Rockies, and still another deep into California.

In these areas evergreens thrive—in the North through long, cold winters with lots of snow, in the Northwest through dampness and year-round cool weather. In summer and winter the forests are green—the trees shed some of their needles from time to time, but there are millions more of them.

Walking through an evergreen forest is like walking on a carpet. The dead needles have formed a floor covering that is soft and springy under your feet.

You stop beside a tall pine. Under it you have noticed a num-

152



Steller's jay

Porcupine

Western tanager

Ground squirrel



Great horned owl

Lodgepole pine

Quaking aspen

White-headed woodpecker

ber of small, oval clumps: owl pellets—indigestible food parts spit out by the bird. You look up. An owl is sitting high in the tree. In another tree nearby, a red squirrel stops picking a pine cone apart and looks at you. In another, a porcupine is sleeping.

Ahead of you, the woods open up into a glade. Here you find a different kind of vegetation—maybe a few birches or aspens, and a covering of ferns and low shrubs, blueberries and huckleberries. And here also you come upon most of the birdlife—kinglets and thrushes, juncos and finches, jays and chickadees.

The farther you get from civilization, the better your chance of seeing our largest American animals. High up in Maine you may surprise a black bear or a moose. In the West, a mule deer or a black-tailed deer may force its way through the thicket ahead of you, and you may come upon a herd of elk.

Black bear (brown phase)

Oregon junco





Belted kingfisher

Deer tracks

Osprey

Streams and Lakes. Our rivers and streams are the veins and arteries that carry life-giving water throughout our land. Wherever water flows, plant life and wildlife abound.

If you happen to be hiking along a gently flowing river, you may come upon a colony of beavers and catch sight of muskrat and mink. Along the riverbank, reeds, sedges, and cattails form a wet jungle that's alive with birds.

Where the river opens up into a lake, you have your best chance to study our diving ducks: canvasbacks, redheads, scaups. At some point along the water's edge, the ground may be crisscrossed by the tracks of deer, raccoon, and opossum. Overhead soars an osprey. And from a branch above you, a kingfisher plunges into the water in a power dive and comes up with a fish.

The large, deep lakes of our Northern States were formed dur-

154

Waterweed

Brown trout

Yellow perch

Hornwort

Black bullhead





Beaver

Weeping willow

Beaver house

ing the ice age more than two million years ago and will probably remain lakes until another ice age comes along. Shallow lakes may slowly be filling up and turning into marshes and fields—but others are being formed all the time. Numerous farm ponds are added each year, and the damming of rivers for electric power or flood control has created thousands of square miles of new lakes.

A lake may seem peaceful and quiet—but it is full of surging life. Various water insects flitter and skim over the water, and your eyes catch the flash of a fish below the surface. What kind will it be? It all depends. In a weedy lake, you may expect to find sunfish and perch; pickerel and crappie; and, in a muddy pond or slow-moving river, catfish and suckers. But any angler will tell you that brook trout or cutthroat trout must be sought in a fast-flowing stream and bass and pike and muskellunge in a clear lake.

Pied-billed grebe

May fly

Calico bass or crappie

White sucker

Eelgrass

Common sunfish





Channeled whelk

Skate egg case

Left-handed whelk

Whelk egg case

Seashore. If you live near ocean or gulf, a hike may take you to the shore. There is plenty to see whether you walk along the “rock-bound coast” of Maine or California, along the beaches of the east coast or the flats of the Gulf.

The plant life is determined by the soil—or the lack of it—and by temperature and tide, by wind and salty spray. Along a rocky coast, you may find groves of storm-gnarled pines. Along sandy shores, you may reach the water’s edge through dunes held in place by beach grass or through thickets of beachplum or bayberries.

Where the coast is rocky, you should have no difficulty finding a tidal pool where some of the water was trapped when the tide went out. Count the number of different periwinkles and other small snails and look for tiny crabs, starfish, mussels, barnacles.

You will find almost as much life on a sandy beach as in a tidal

Rockweed
Sea moss

156

Bluefish

Sparring

Hermit crab (in moonshell)

Sheepshead porgy

Blue crab

Sea lettuce

Common starfish

Butterfish

Soft-shell clam (dead)

Bay scallop (dead)

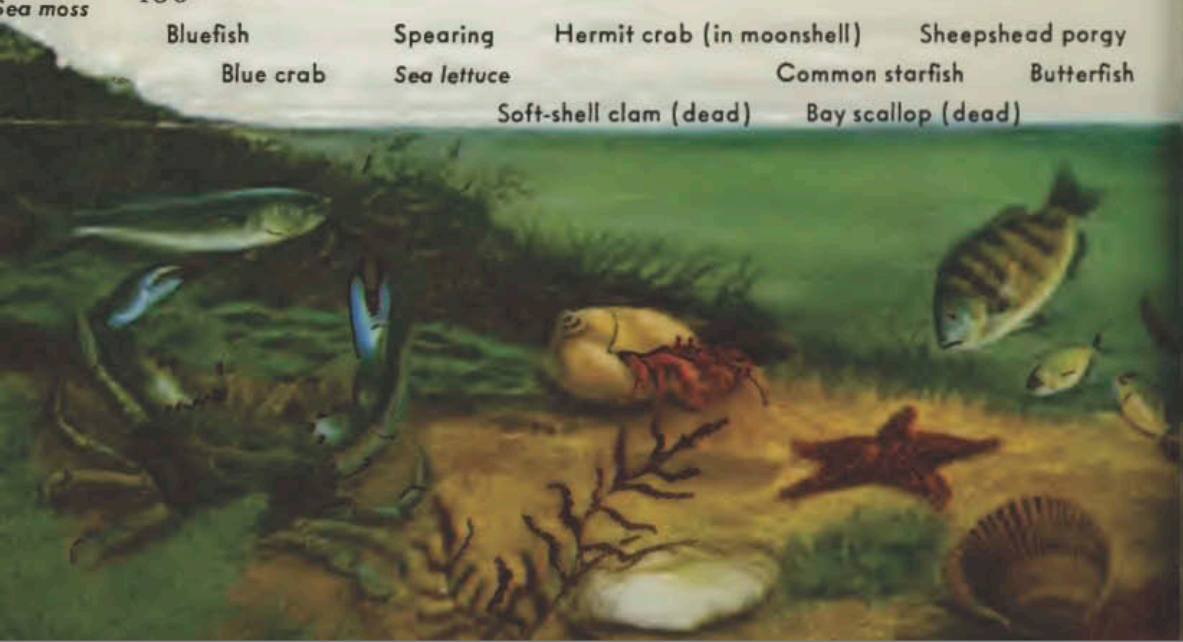



Horseshoe crab (dead)

Semipalmated sandpipers

Common terns

Herring gull

pool, but you will have to look closer for it. You may see the tracks and the holes of fiddler crabs or ghost crabs; the shells of dozens of different kinds of mussels and chitons and whelks; the quaking masses of stranded jellyfish; and, where the water is warm, the bloated balloons of Portuguese man-of-war. Sandpipers sweep down in flocks of a dozen or more and run along the water's edge, thrusting their bills into the sand to pick up tasty morsels. Terns skim over the water on long, pointed wings, and gulls settle down on the waves for a few moments of rest.

You may have the idea that here, at least, is a place where plant life is of little importance. But you'll be wrong. In addition to seaweeds, the ocean is full of tiny plants—algae—that make up the main food of small water creatures and tiny fish which are eaten by larger fish, which in turn are eaten by still larger ones.

Blue jellyfish

Blue mussels

Portuguese man-of-war
Razor clam (dead)

Common
mackerel

Oyster (dead)

Rock barnacles

Periwinkle

Fiddler crab

Irish moss





cca Saguaro cactus Cactus wren Desert sparrow Beaver-tail cactus
 Gila woodpecker Staghorn cholla Roadrunner Zebra-tailed lizard

Western Deserts. To most people, the desert is a desolate, uninhabited place with little beauty. They just haven't taken the time or picked the season to look. Come into the deserts of Arizona or New Mexico or California in April or May when rain sweeps across the parched land. Then the desert blossoms out—with cactus and yucca in bloom and the ground covered with tiny flowers.

Here you have proof that water is the only thing needed to turn a desert into a garden spot—the soil of most of our deserts is rich in plant food. Where it has been possible to irrigate the soil, the desert has provided land for cultivation—for citrus trees in the South, for grain and pasture farther North. Perhaps someday within your lifetime, when someone has invented a cheap way of making fresh water from salt water, our western deserts may become orchards and fields irrigated by water from the Pacific.





Beaver-tail cactus *Scissor-tailed flycatcher* *Badger* *Crissal thrasher* *Teddy bear cholla*
Ocotillo *Gila monster* *Century plant*
Yuma antelope squirrel *Horned lizard*

In the middle of the day, a desert seems without life—most animals and birds are hiding from the heat. A roadrunner may scurry over the sand, and you may see and pick up a horned toad—which isn't a toad at all but a lizard. But don't pick up a Gila monster if you find one—it is our only poisonous lizard.

In the cool of the evening, the desert comes alive. Desert mice, pack rats, kangaroo rats, ground squirrels, leave their burrows and hustle about for plant and insect food, and diamondback rattlers and sidewinders go hunting. The tiny elf owl flies out from its nest. Jackrabbits, spotted skunks, foxes, and coyotes go on the prowl.

By daybreak, most of the animals seek shelter. But that is the time to see the desert's birdlife. Woodpeckers hammer for insects, flycatchers snap them from the air, thrashers peck for them in the sand. Warblers and orioles sing from their perches.

Prickly pear *Spotted skunk* *Western diamond rattler* *Kangaroo rat* *Barrel cactus*





TRAILING, TRACKING, AND STALKING

On a hike, you'll get a real kick out of seeing a rabbit or a deer leap across your path or a racoon scurry into the thicket. But wouldn't it be far more fun if you could get so close to the animal that you could see what it is doing, how it lives?

To do that you have to be quite an outdoorsman, familiar with the woodman's skills of trailing, tracking, and stalking.

You have to be good at trailing before you can become good at tracking. Trailing is the ability to follow the deliberately made trail marks arranged by one outdoorsman for another to follow.

In tracking, on the other hand, you follow the casually made marks—tracks and traces—of an animal as it roams through woods and across fields. It takes keen observation to see the marks the animal made and to follow them until you hit upon the animal's hiding place.

And after that, you have to be so good at stalking that you can sneak up close enough to watch the animal without scaring it away. Stalking is one of the most American of all Scoutcraft skills. The early Indians and pioneers were expert stalkers.



TRAILING

8a  Follow for half a mile a trail made with trail signs or by a person wearing tracking irons or dragging a whifflepoof.

(NOTE: For Second Class, do trailing *and* either tracking or stalking; or do the combination of tracking and stalking instead.)

Trail Signs. Scout trail signs are scratched in the ground with the point of a stick or shaped from twigs or pebbles. A small arrow means "This is the trail." An *X* is a warning, "This isn't the trail—don't go this way." A square with a number in it and with an arrow means "I've hidden a message in this direction, as many steps away as the number says." A circle with a dot in the middle tells you "This is the end of the trail," or "I have gone home."

When you follow a trail made up of trail signs, *use your eyes and take it easy*. Be sure that each sign is actually a sign and not one you are just imagining. If you think you have missed a sign, go back to the spot where you brushed out or undid the last one and start off again.

If you don't wipe out the signs as you go along you may cause a lot of confusion for other patrols or even for yourself the next time you hike through the same place.

SCOUT TRAIL SIGNS



"This is
the way."



"Message 3 steps
this direction."



"This is not
the way."



"I have
gone home."

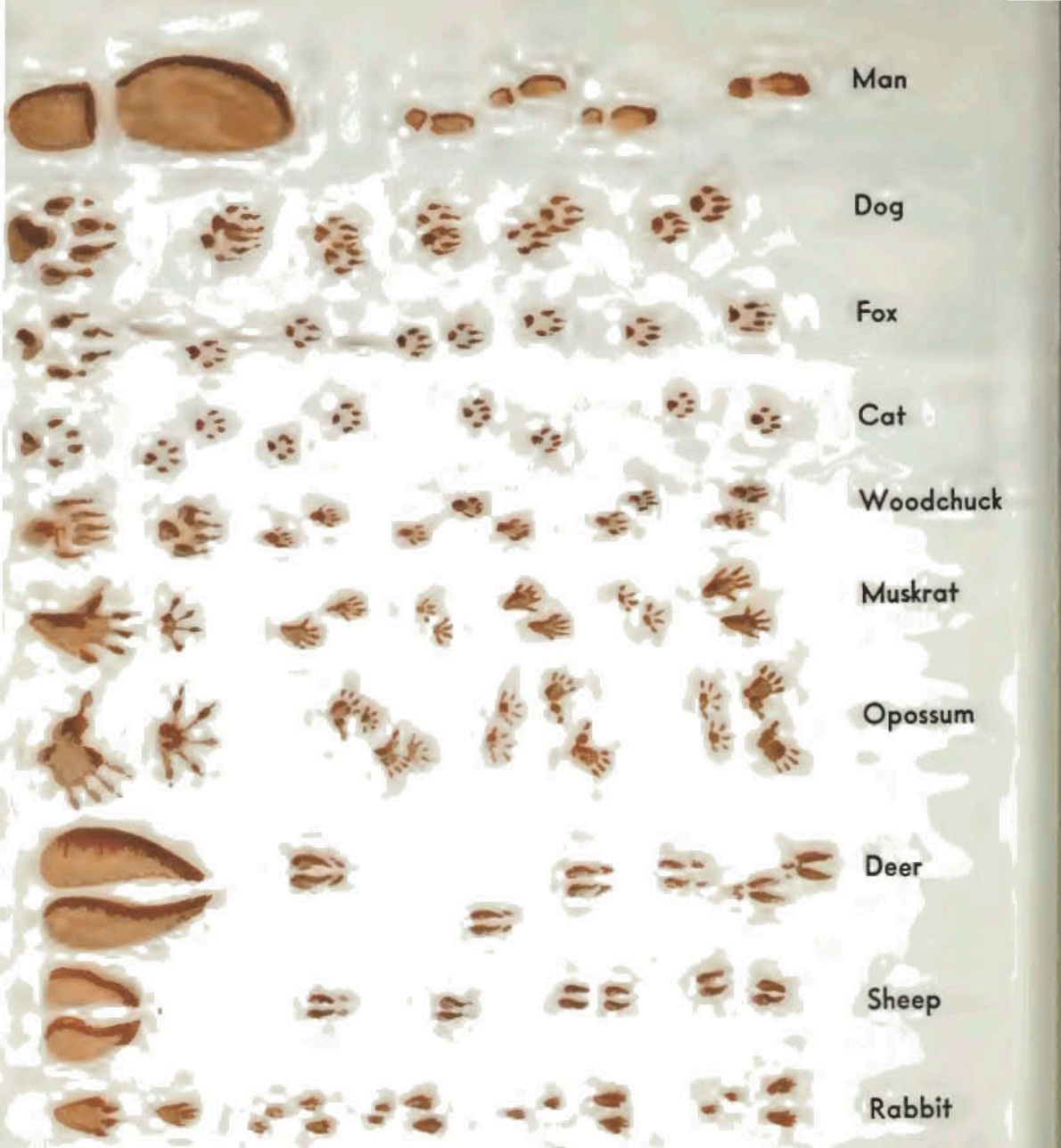

Man

Dog

Fox

Cat

Woodchuck

Muskrat

Opossum

Deer

Sheep

Rabbit

Note: Tracks are not to same scale.



over the ground a little farther away. By continuing in this way you can cover the whole area in front of you thoroughly.

Following a Track. Before you set out to follow a track, decide what animal made it and fix the details in your mind. Then you can be sure that you are always following the right one, even when farther along other tracks may be mixed in with it.

A good look will tell you how old the track is. If it is blunted by rain it must have rained since it was made. So ask yourself, "When did it rain last?" The wind may have blown grass seeds or leaves into it. "When did the wind blow?" The fresher the track, the better your chance to find the animal that made it.

If possible, track toward the sun. The tracks are much easier to see then. The shadows make them look deeper and sharper.

As you follow the track, look up and ahead. It may be all right for a bloodhound to keep his nose to the ground and sniff at each track, but not for you. Instead, look at the track as a whole. The imprints of the whole track often stand out plainly where it may be hard to see the separate tracks. Through grass, for instance, a track looks like a streak because the bent grass reflects the light differently from the rest. On hard ground the track may show up through a number of small details—displaced pebbles, cracked twigs, turned-over leaves that show their damp and, therefore, darker underside.

If you lose the track at any time, say to yourself, "Where would I go from here if I were the animal?" Look in that direction. If that still does not help you pick up the track, mark the last imprint with a stick or with your handkerchief and "cast" around this marker—that is, walk around it in an ever-widening spiral until you find the track again.

Careful now! Those last tracks look as if they are freshly made. The animal you are tracking may be just ahead of you. Stop, look and listen! There it is! Now stalk up close to it!

A whifflepoof—a log with nails in it—gives training in trailing and tracking.



STALKING

There is adventure to stalking. It is also a wonderful physical-fitness conditioner. It takes plenty of muscle control to walk silently and to keep your body in perfect balance at all times. And it takes strength to move forward in the unaccustomed positions that stalking calls for, using muscles you don't realize you have.

8c 🦋 *Follow another Scout who knows that you are stalking him for a distance of a half mile, without being seen by him. (NOTE: For Second Class, do stalking and either trailing or tracking; or do the combination of trailing and tracking instead.)*

Stalking Hints. Some animals have sharp eyesight—others are nearsighted: They see movement but not details. Most of them depend on their keen senses of smell and hearing for protection.

If an animal gets your scent or hears you, good-bye! Therefore, approach it carefully with the wind in your face. If you have discovered it from the wind side without disturbing it, make a half circle around it before you continue. To find the wind direction on a still day, wet a finger in your mouth and hold it up. The side toward the wind will feel cooler.

Silent motion is important. Move slowly and carefully. A quick or jerky motion is easily detected and may scare the animal. Watch where you place your feet—the cracking of a dry twig may sound like a pistol shot. Move ahead swiftly when wind rustles the leaves.

Have your body under complete control. If the animal detects

How good a stalker are you? How close can you get to a herd of grazing deer?

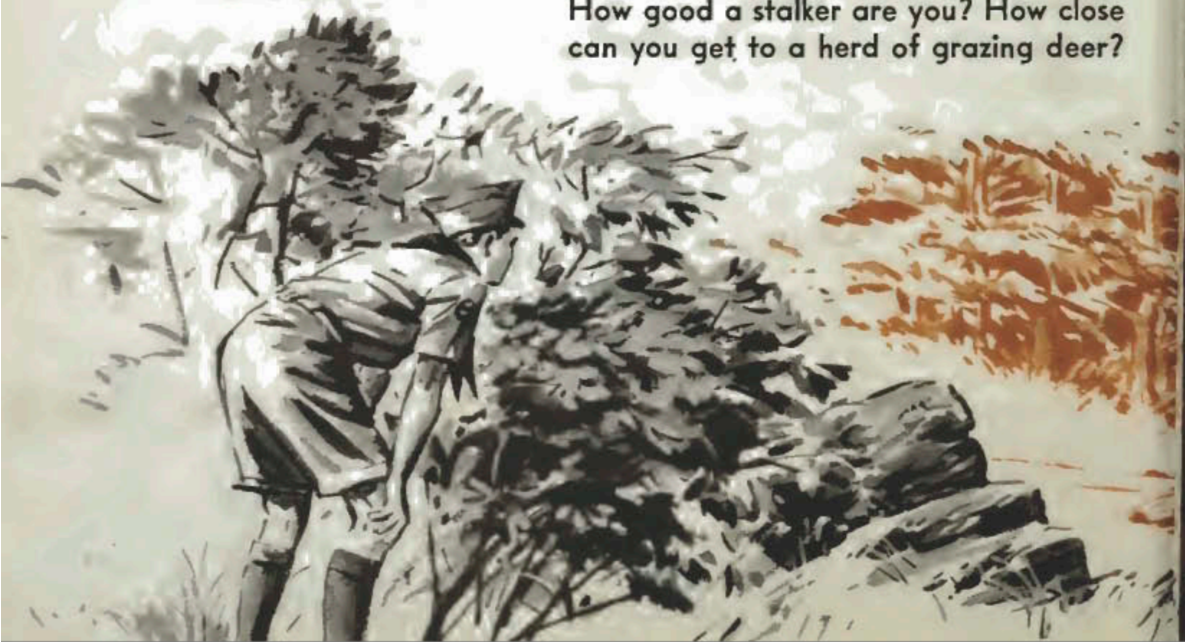

Keep low when you cross a ridge.



Wrong

Right



Right

Looking from behind tree, keep close to the ground.



Learn to "freeze" (left).



Wrong

Never look over a rock (above). Look from side (right).



Right

you, "freeze" on the spot—that is, become absolutely motionless. If you keep perfectly still, the animal may look directly at you without noticing you, then quiet down again. Did you ever see a cat "freeze" in front of a mousehole? That's the idea.

Choose the right background. In Scout uniform you blend naturally into underbrush and grass. But whatever you wear, against the sky you will always show up sharply. So keep low if you have to cross a ridge.

Make good use of anything that will hide you—trees, stumps, bushes, rocks, large clumps of grass. Do not look out from the side of a tree—get down low next to the trunk. Never look over a



rock—look around it with your head close to the ground. To prevent your shadow from giving you away, stick close to your cover so that its shadow blends with yours.

The way you hold yourself depends on how close you are to your quarry and the cover you have to hide behind. If you are far away among trees and high shrubs, use an upright position. If the bushes are low, crouch and move ahead with knees bent and your body leaning from the hips. Closer to your prey you may have to get into a “cat creep”—creeping on hands and knees with your back flat, your head and buttocks low. In low grass, you may have to worm along in a belly crawl—pushing yourself forward with chest and stomach to the ground, drawing up one leg, digging it in, straightening it out.

Practice Does It. This stalking business is not something you can learn by reading about it. You need practice—lots of practice. And the best practice you can get is right in your own patrol, playing stalking games until you get so good that you can sneak up on your patrol pals without being heard or seen.

Here are a few games that will give you the idea:

SLEEPING PIRATE—One Scout is the “pirate.” He is blindfolded and sits on a log, guarding an empty matchbox at his feet. The other fellows form a circle around him, about 100 feet away. The idea is to sneak up to the pirate, take the box, and return with it to the starting point without being heard. If the pirate hears you, he claps his hands and points. If he points to you, you’re out! The successful stalker becomes the next pirate.

WARY WOLF—One Scout is the “wary wolf.” The others stand in a line about 200 feet from him. He turns his back to them, whereupon they try to approach him. From time to time the



wolf turns around quickly and faces the others, and everyone “freezes.” Any Scout making the slightest motion is sent back to the starting line to begin again. First Scout to touch the wolf is the winner and becomes the next wolf.

DEER STALKING—One Scout is the “deer” and takes up a position in a forest or a field. The other patrol members walk away from him 200 feet in different directions, where all fall down. On a signal the Scouts move toward the deer, using whatever cover is available. When the deer sees a Scout, he yells to him to stand. The Scout who comes closest without being seen wins and becomes the next deer.

PATROL AGAINST PATROL—Two patrols line up 200 feet from each other with the Scouts about 30 feet apart. On a signal the Scouts fall flat to the ground and proceed to stalk toward the opposite team. If a Scout in one patrol gets near enough to a Scout in the other patrol to identify him, he calls out his name, and the Scout identified goes out of the game. The winning patrol is the one that gets most Scouts through the opposite line in a given time.

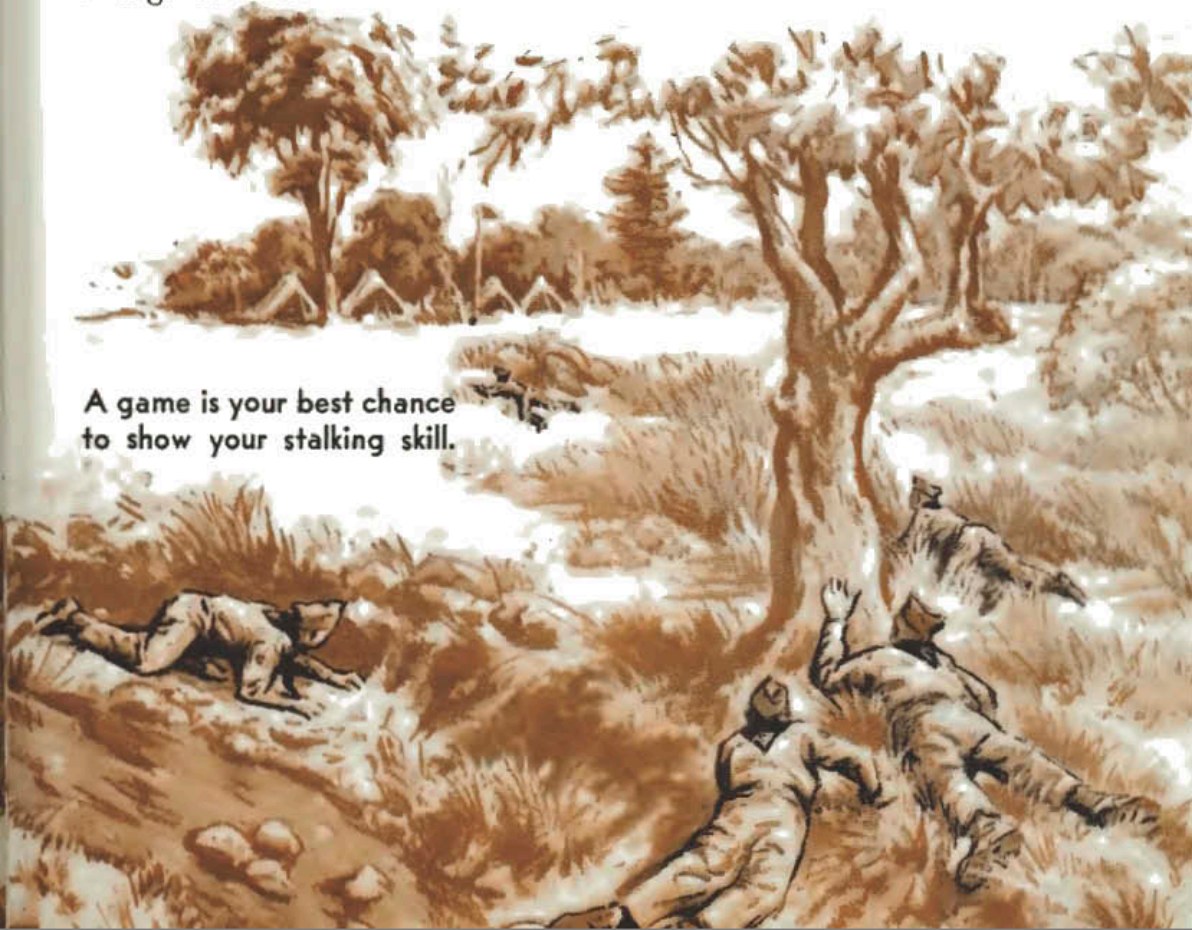

A game is your best chance
to show your stalking skill.

THE TOOLS OF A WOODSMAN



Boy Scout knife



Boy Scout sheath knife



Handle knife safely.

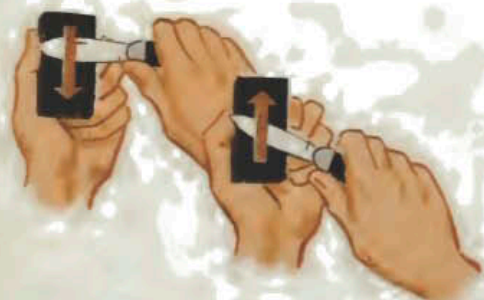

Use dry sharpening stone.

A real outdoorsman can make himself comfortable and at home on a desert island with a knife and an ax as his only tools. They are his most useful friends and, therefore, should be treated kindly always.

Your Knife

The official Scout knife is the most popular knife among outdoorsmen. It has a strong cutting blade and various tools as well—can opener, bottle opener, screwdriver, leather punch or awl. Your knife is a valuable tool, so take good care of it.

Keep it clean, dry, and sharp.

Don't use it on things that will dull or break it.

Keep it off the ground—moisture and dirt will ruin it.

Keep it out of the fire—the heat draws the temper of the steel and makes the edge soft and useless.

Wipe the blade clean after using it, then close the knife. Oil joints and springs occasionally.

9 *Correctly sharpen a knife ... and give rules for ... safe use.*

Sharpening Your Knife. The keener the edge, the safer your knife. A dull knife is always dangerous because it doesn't bite into the

wood properly and therefore cannot be controlled. In addition, a dull knife gives you a lot of extra work even if you do manage to whittle with it.

Sharpen your knife on a dry sharpening stone. Lay the blade edge on the stone, raise the back of the blade slightly and stroke the full length of the edge across the stone toward you in a slicing motion—as if you were cutting into the stone. Turn the blade over and stroke it away from you the next time. Continue back and forth until the edge is sharp. Wipe the blade.

Using Your Knife. For crude work with a knife, always whittle away from yourself to prevent injury. For advanced whittling, move the knife in short, careful cuts.

In making wood shavings for tinder, hold a dry stick by one end with the other end pointing away from you. Make a shallow cut with the knife blade, then draw the edge parallel to the surface of the stick for as long a stroke as possible until the shaving comes loose.

Fuzz sticks are even better than loose shavings for starting a fire. To make a fuzz stick, cut the shavings as long and as thin as possible, but leave them on the stick in a fuzz that'll make the stick look like a small Christmas tree. Three or more fuzz sticks will do the trick for quick fire starting.



Cut a branch at a slant across the grain.

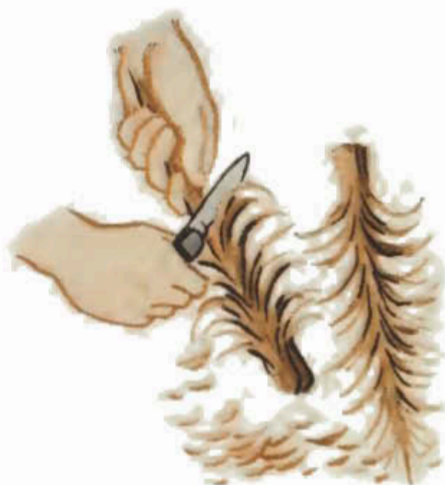

Fuzz-stick making is a good test of your ability.





When cutting brush, strain the grain first by bending.

YOUR AX

Firewood and axmanship go together—they always have, throughout the history of America. The early settlers and pioneers needed plenty of fuel for their fireplaces to survive the winters.

Most of your hikes will probably be axless—you can usually break the firewood you need for a quick hike meal with your hands or under your foot. But if your fire is to burn for any length of time or the woods are wet, you had better bring an ax for chopping and for splitting your fuel. Good for this purpose is the official Scout hand ax, with its 1¼-pound head set on a springy hickory handle.

On a hike, carry the ax in its sheath in your pack. Carry it around camp by holding the handle near the head with the edge down.

9  *Correctly sharpen . . . [an] ax and give rules for . . . safe use.*

Care of Your Hand Ax. Your ax, like your knife, deserves good care.

Keep the edge or “bit” sharp—not just sharp enough for it to chew, but sharp enough to bite!

Keep the handle tight; if it gets loose, tighten the screw if it has a screw wedge or drive in the wedge harder if it has a hardwood

wedge. The official Scout ax is treated in such a way that the head will not come loose.

Don't let your ax touch the ground—driving it into the ground will nick it, leaving it on the ground will rust it. Always have a chopping block under the wood you are chopping or splitting.

When you are through using the ax for awhile, stick it in the chopping block. When you have finished using it for the time being, put it back in its sheath. To keep the edge covered in these ways is called "to mask" the ax.

Your ax wasn't designed to drive tent stakes. Never use it on steel stakes or wedges as this will open up the "eye" of the head and make the handle come loose.

And never touch a live tree with your ax—unless you have definite permission to do so and a definite use for its wood.

Sharpening Your Hand Ax. To keep your ax sharp, hone it regularly with a sharpening stone and touch up the edge when needed with an 8-inch flat mill file.

For *honing*, hold the head of the ax in one hand in such a way that the handle points up and away from you and rub the dry stone over the edge with a circular motion, from one end of edge to the other. Then turn the ax over with the handle now pointing down and hone the



Boy Scout hand ax



Sharpening against log.



Sharpening against peg.



Circular strokes for honing.



Contact chopping method.



Two-log chopping method.

other side in the same way, until the edge is so keen that it no longer shows up as a bright line when you look at it.

For *filing*, lean the axhead against a log or against a peg driven in the ground. Kneel on one knee and place your other foot on the handle to keep the ax steady. Place the file on the edge and push down hard. File the whole edge with long, even, straight strokes, working along the blade from one end to the other. Keep the file in light contact with the edge on the return strokes. Work slowly and with care, holding your file firmly to avoid cutting your fingers. When you have done one side, turn the ax over and do the other side. Finish with a few honing strokes of the sharpening stone.

Using Your Hand Ax. Before you start cutting, get a chopping block. In deep woods, there'll probably be a down tree or a stump you can use. If not, use the thickest chunk of wood you have for a chopping block. The point is that you must have wood support under the stick you are chopping or splitting, so that the ax stroke will end up in wood and not in the ground.

For *chopping* a stick in two, hold the ax edge against the stick to be cut on a slant to the grain rather than straight across the stick. Raise stick and ax together and bring

them down hard together on the block. If the stick is too thick to cut with this "contact method," place the stick with the spot where you want to cut it on the chopping block and cut a V-shaped notch. Make top of V as wide as stick is thick. Kneel on one or both knees when chopping with a hand ax.

For *splitting* a stick, again use the contact method: Place the edge of the ax parallel to the grain at the end of the stick. Lift stick and ax together and bring them down hard together on the chopping block. Just after you hit the block, twist the wood slightly against the ax to break the pieces apart.

Remember, in using the ax, that it is not brute force that counts, but the keenness of the cutting edge and the weight of the axhead behind it. Lift the ax just high enough in a smooth wrist-and-forearm motion, aim it by looking at the point where you want the cutting edge to strike, then let the ax fall in a guided drop. Easy does it!

Remember that not only wood but people as well can get chopped. Keep your buddies away from you when you are using your ax.

Rest when you are tired. You have no control over your ax when you are tired—and an ax out of control is a dangerous weapon.

Pass the ax to another person with its harmless end first—that is, handle first, axhead down.



Cut thick branch with a V notch. Top of V should be as wide as branch is thick.



Contact method for splitting.



YOUR HIKE MEAL

“When do we eat?” That’s an important question when you’re on a hike. There’s nothing to make you hungry like roaming the woods and the fields. The excitement of being out with the gang, the fresh air in your lungs, the exercise—all of these make you feel hungry enough to eat an ox.

“What’ll we eat?” That’s another question. There probably won’t be an ox around, so you need to have another answer to that question even before you set out.

On many hikes you won’t want to be tied down to cooking a meal. There may be some special training you want to do—tracking, for instance, or first aid or pioneering. For hikes of this kind, you’ll very likely want to take a sandwich along with maybe an apple, an orange, or a banana for dessert. Or you may invent a hike ration of your own: a few graham crackers, a handful of raisins, a handful of nuts, and a handful of chocolate bits.

But there’ll be plenty of other times when you’ll want to stop on the hike for an honest-to-goodness hot meal right off the fire. Then it’s a matter of knowing how to prepare kindling and firewood with knife and ax, make a fire, cook a simple meal, and clean up after it.

PREPARING FIREWOOD

There's a famous little verse by Ernest Thompson Seton, first American Chief Scout, that tells you how to make a fire:

First a curl of birchbark as dry as it kin be,
Then some twigs of softwood, dead, but on the tree,
Last o' all some pine knots to make the kittle foam,
An' thar's a fire to make you think
you're settin' right at home.

The first line of the verse deals with *tinder*, the second with *kindling*, the third with *fuel*. And those are the three things you need for making a fire.

10a 🦋 Use an ax correctly to prepare kindling or fuel wood.

Tinder. Tinder is the kind of stuff that flares up when you touch it with the flame from a burning match. You need a good handful of it.

What'll you use? Well, what've you got? Look around.

Any grapevines or cedars or birches out your way? They'll give you excellent tinder. The outer bark of old grapevines and cedar trees peels off in long flakes; the bark of white and yellow birches, in thin "feathers"—you can pick off these flakes or feathers with your fingernails without harming the vines or the trees. The outer bark of the gray birch is tops, too, but it sticks firmly to the tree—if you try to remove it, you harm the tree. So look for a dead branch or a stump and take a strip of bark from that.



Any pines or firs or spruces around? You will find a lot of tiny twigs on the trunks of the young trees—they seem to sprout right out of the bark. The small cones of certain evergreens are good, too.

Are the trees in your neck of the woods mostly those with broad leaves? Then make tinder by breaking a dead branch and whittling it into thin shavings with your knife.

If there is nothing else around, last year's dry weed tops of goldenrod, yarrow, aster, and wild carrot will do for tinder. So will the stalks of cattail and other coarse grasses. But thin grass and dry leaves will be of little help—they flare up with hardly any heat.

Kindling. Kindling catches the flame from the tinder and in turn ignites the heavier fuel.

In the woods in dry weather, you can use sticks you find on the ground. But far better are dead branches still on the trees, so-called "squaw wood"—the kind the Indian women used to collect by simply breaking it off. Take only branches that snap easily. If they just bend they are too green for a fire. "If you can't snap it, SCRAP IT!" Gather a couple of handfuls of these branches, pencil thin or thinner.

Fuel. For fuel, use whatever wood you can get from a fallen limb or a dead branch from a tree. Break or



TINDER
from bark:
Cedar
Birch
Tulip
Basswood
Elm
Grape

TINDER from
weed tops:
Goldenrod
Aster
Yarrow
Wild carrot
Milkweed
Cattail

KINDLING
from trees:
Evergreen
twigs
"Squaw wood"
Cottonwood
Willow
Alder
Aspen

FUEL from
trees:
Hickory
Oak
Beech
Birch
Maple
Ash
Mesquite

chop it into pieces of suitable length for your fire—about a foot or so. Some woods burn more easily than others—but almost any wood is usable for a quick meal.

In woodless areas you will have to bring your fuel with you or get along with whatever materials you can find that will burn. Even desert areas and mountains have low-growing shrubs from which you can get dead twigs or roots. And you have probably heard that the Plains Indians used “buffalo chips” (dried cattle dung) for their cooking fires.

MAKING YOUR FIRE

You have your tinder, your kindling, your fuel—you’re rarin’ to light your fire. Hold your horses for just another moment while you remind yourself of your Tenderfoot knowledge about safety with fire. OK? Fine! And there you go:

10b 🐾 *Build a fire on a safe spot using not more than two matches*

Preparing a Safe Fire Site. First of all, clean the spot where you intend to build your fire down to plain dirt—sand, gravel, clay, or rock. Then, for a distance of 10 feet, scrape the ground around the spot bare of any material that may catch fire from a flying spark—dry grass, leaves, pine needles, and the like.

The safest fire is built directly on gravel or on solid rock.



In woodlands, remove flammable material for a 10-foot circle. On grassland, prepare spot by digging up sod. Replace sod afterward.

Now, and only now, you are ready to lay your fire. What kind shall it be? Campers have a slogan for the kind of fire they need for cooking: "Flames for boiling—coals for broiling." For preparing a hike meal, almost any kind of small fire will do.

Tepee Fire Lay. The tepee fire lay got its name for its resemblance to the shape in which the Indians put up the poles when erecting their tepees. It is an easy fire to build on a hike. In camp you will find it especially good for boiling and frying.

Place a large handful of tinder on the ground in the middle of your fire site. Push a stick into the ground, slanting over the tinder. Then lean a circle of kindling sticks against the slanting stick with their tips together and with a "door" toward the windward side of the draft.

To light the fire, crouch in front of the fire lay with your back to the wind. Strike a match. Turn it in such a way that the tiny flame licks up along the matchstick. Let it burn into a real flame while you cup your hands around it for protection. Now touch the flame to the tinder close to the ground.

It caught! And a few minutes later, the tinder has ignited the kindling. Let the kindling get a good start. Then feed the fire from the downwind side, first with thin pieces of fuel wood, then gradually with thicker pieces. Continue feeding until the fire has reached the size you want.

Crisscross Fire Lay. This fire got its name from the way in which each layer of sticks is placed on the layer below it. It is your best bet when you need a bed of coals for broiling and baking.

Place two sticks of wood, about as thick as your wrist and about a foot long, on the ground parallel to each other, a hand span apart. Put a large handful of tinder between them. Then lay a number of thin kindling sticks a little-finger width apart crosswise on top of this first layer. Continue building up crisscross layers, increasing the thickness of the wood from layer to layer, but always placing the pieces a little-finger width apart. Eight layers is enough. Light tinder near ground from windward side.

When properly laid, the crisscross fire lay will flare up with a blaze and then quickly turn into a bed of glowing embers.

TEPEE FIRE LAY

Place tinder on ground. Slant a "lean-to" stick over it. Arrange kindling sticks in shape of Indian tepee. Light from the side the wind comes.

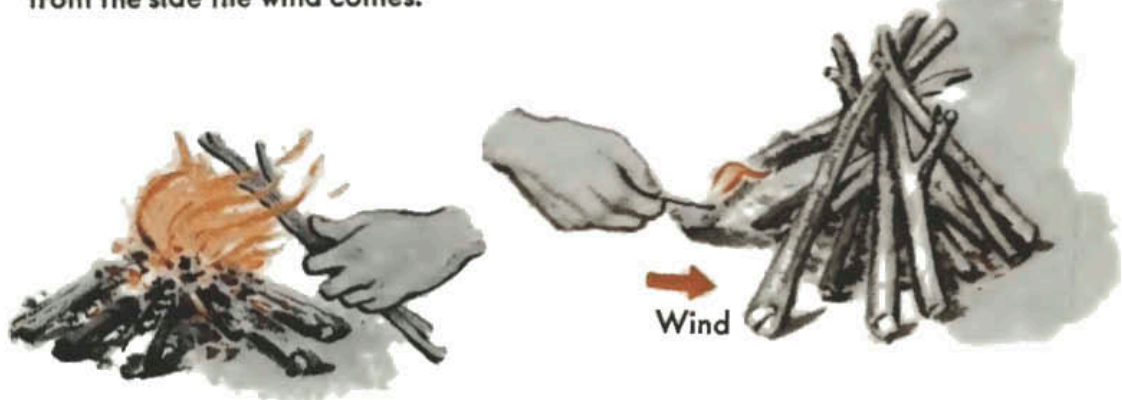

CRISSCROSS FIRE LAY



Place tinder between two thick sticks. Arrange other sticks in crisscross layers.



Now, and only now, you are ready to lay your fire. What kind shall it be? Campers have a slogan for the kind of fire they need for cooking: "Flames for boiling—coals for broiling." For preparing a hike meal, almost any kind of small fire will do.

Tepee Fire Lay. The tepee fire lay got its name for its resemblance to the shape in which the Indians put up the poles when erecting their tepees. It is an easy fire to build on a hike. In camp you will find it especially good for boiling and frying.

Place a large handful of tinder on the ground in the middle of your fire site. Push a stick into the ground, slanting over the tinder. Then lean a circle of kindling sticks against the slanting stick with their tips together and with a "door" toward the windward side of the draft.

To light the fire, crouch in front of the fire lay with your back to the wind. Strike a match. Turn it in such a way that the tiny flame licks up along the matchstick. Let it burn into a real flame while you cup your hands around it for protection. Now touch the flame to the tinder close to the ground.

It caught! And a few minutes later, the tinder has ignited the kindling. Let the kindling get a good start. Then feed the fire from the downwind side, first with thin pieces of fuel wood, then gradually with thicker pieces. Continue feeding until the fire has reached the size you want.

Crisscross Fire Lay. This fire got its name from the way in which each layer of sticks is placed on the layer below it. It is your best bet when you need a bed of coals for broiling and baking.

Place two sticks of wood, about as thick as your wrist and about a foot long, on the ground parallel to each other, a hand span apart. Put a large handful of tinder between them. Then lay a number of thin kindling sticks a little-finger width apart crosswise on top of this first layer. Continue building up crisscross layers, increasing the thickness of the wood from layer to layer, but always placing the pieces a little-finger width apart. Eight layers is enough. Light tinder near ground from windward side.

When properly laid, the crisscross fire lay will flare up with a blaze and then quickly turn into a bed of glowing embers.

TEPEE FIRE LAY

Place tinder on ground. Slant a "lean-to" stick over it. Arrange kindling sticks in shape of Indian tepee. Light from the side the wind comes.



CRISSCROSS FIRE LAY



Place tinder between two thick sticks. Arrange other sticks in crisscross layers.



COOK YOUR HIKE MEAL

Cook your hike meal woodsman style, without the use of pots or pans. The secret of that kind of cookery is in the fire. Let it burn down into a bed of clean coals before you use it.

10c ♪ cook—without utensils—a meal from raw meat (or fish or poultry) and at least one raw vegetable.



Bake potatoes in the ground under hot coals.



Rustic broiler from a forked branch and a few thin sticks.

Broiled Steak and Baked Potatoes.

For one serving: $\frac{1}{2}$ -pound steak; two medium potatoes; a pinch of salt. Before starting the fire, scoop a hole in the ground a little deeper than the thickness of your potatoes. Start a fire over the hole and keep it going for half an hour. Push the coals aside with a stick, place the potatoes in the hole, cover them with a $\frac{1}{2}$ -inch layer of dirt, and push the fire back over them. Put on more wood and keep the fire going for about an hour more. In the meantime, make a rustic broiler from a thin, forked stick by twisting the prong into an eye and placing cross sticks on it to hold the meat. Broil the steak on this broiler for about 8 minutes on one side, 8 on the other. Test the potatoes in the coals by pushing a sharp, pointed stick into them. When the stick

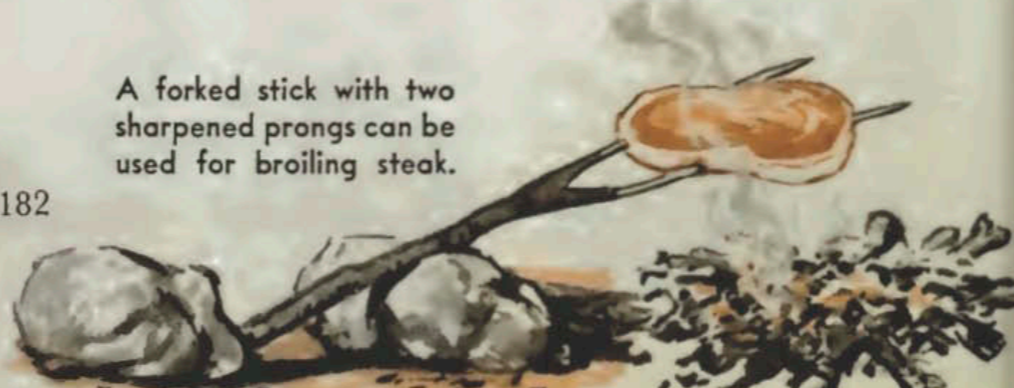

A forked stick with two sharpened prongs can be used for broiling steak.

goes in easily, the potatoes are done. Season with salt.

Caveman Steak and Roast Corn. For one serving: $\frac{1}{2}$ -pound steak; two ears of corn; a pinch of salt. Open the corn husks without pulling them off, remove the silk completely, and close up the husks again. Soak the ears in water a few minutes. When fire has burned down to coals, blow away the ashes and place the steak directly on the glowing embers. Place corn next to steak. Turn steak and corn once—after about 8 minutes—and cook on the other side for 8 minutes. Season with salt.



Steak can be broiled and corn roasted directly on the coals.

Kabob or Shish Kebab. For one serving: $\frac{1}{4}$ -pound steak or lamb shoulder cut into 1-inch cubes; one onion, peeled, cut lengthwise, and opened into separate leaves; one small tomato, cut into quarters; a pinch of salt. Make a skewer from a straight stick as long as your forearm and as thick as a pencil. Sharpen the thinner end of the stick to a point. String meat, onion, and tomato alternately onto the stick. Place skewer over the coals on two small forked sticks or rest it on two stones, one on each side of the coals. Cook 10 to 15 minutes. Season with salt.



For kabob, string meat and vegetables on a slender, pointed stick.

Kabob is one of the most satisfactory hike meals.



Barbecued Chicken and Tomatoes. For one serving: chicken leg and thigh; three or more cherry tomatoes. Find a forked stick and sharpen the points of the two branches. Impale the chicken leg on the prongs in the way shown for a steak on the bottom of page 182. Cut a straight, thin stick and sharpen the tip. Push the cherry tomatoes onto the end of the stick. Using a couple of stones, arrange the two sticks over a bed of hot coals with chicken and tomatoes 6 to 7 inches above the embers for slow cooking. Turn occasionally. Cook 30 to 40 minutes until meat is tender. Season with salt.

Broiled Fish and Mushrooms. For one serving: two to three brook trout or other fish of similar size; three domestic medium-sized mushrooms; one pat of butter. Clean the trout by scraping off the slime, opening up the belly and removing entrails and blood next to the backbone. Make a rustic broiler as described on page 182. Place the fish on the broiler and hold them in position with a few cross sticks. Push the handle of the broiler into the ground in such a way that the fish are suspended over the coals. Broil about 5 minutes on each side. Do not overcook. In the meantime, rake some of the coals to one side, break off the stems of the mushrooms and place the caps, gill side up, directly on the coals. Drop a small piece of butter in each cap. When butter has melted, mushrooms are done. Season with salt.



Extinguish your fire by sprinkling it thoroughly with water.



Turn smoldering sticks and logs over and drench them on all sides.

Clean Up and Put Out

Ummm! What a meal that was! You are full of energy. Now to continue your hike. But there's a double job to be done before you leave—of cleaning up and putting out.

10d 🦋 *Properly dispose of garbage, put out your fire, and clean up the cooking area.*

Cleaning Up. The best cleaning-up rule is: "Make no mess, and you have no mess!" The less mess you have made, the quicker you will have everything in shape. Do a thorough cleanup job. Overlook nothing.

Before putting out the fire, burn whatever garbage will burn: paper, vegetable peelings, steak bones. What won't burn, take with you to put in your garbage can at home. Bring along an empty litter bag specifically for this purpose.

Putting Out the Fire. It is criminal to leave a fire that is still alive. Be positive that yours is out, that the last spark has been **DROWNED!** Sprinkle (do not pour) water on the embers. Stir with a stick until soaking-wet ashes remain. Turn logs and sticks and drench both sides. Wet the ground around the fire. Finally cover the spot with dirt or bury the wet ashes. Make the place look as if no one had been there.



Continue using water until only soaking-wet ashes remain where you had your fire.



Bury wet ashes or cover spot with dirt.

EMERGENCY PREPARATION

An elderly couple was driving along the highway when their car skidded and smashed into a telegraph pole. The husband had a gash on his forehead, but the wife was not hurt. They sat stunned for awhile not quite knowing what to do. Suddenly the wife caught sight of a couple of khaki-clad boys running down the road toward them. She turned to her husband and with a sigh of relief and said, "Here come two Boy Scouts. They'll know what to do."

People have come to know that Scouts are being trained to take care of themselves and to help others; they trust the Scouts to come to their aid in an emergency.

You are almost certain, in your own life, to come up against a number of different emergencies calling for immediate action. Some of these emergencies will be small—such as taking care of a cut or a scratch. Others may be large—getting the victim of an automobile accident to the hospital or calling the fire department to a burning house. By learning in advance exactly what to do, you will be ready to help the moment an emergency strikes.

GETTING HELP

Some emergencies are so serious that one person cannot handle them. Then it is important to know how to get help.

11a  *Tell how, in an emergency, you would reach a doctor or a hospital.*

By Telephone. The easiest and quickest way to call for help is by telephone. At home, you should have the telephone numbers of doctors and hospital written on a card next to the telephone.

If you need help, rush to the nearest telephone (in town, to the



nearest shop; in the country, to where you see a telephone wire enter a house) and dial or call the operator. In using a pay telephone you will need a dime to get your call through, so always carry an "emergency dime" in your pocket. As soon as the operator answers, give the number if you know it; otherwise say:

"I want an ambulance in.....(give name of town)" or

"I want a policeman in.....(give name of town)" or

"I want to report a fire in.....(give name of town)."

When the operator has connected you, make your report clearly and distinctly in terms of the three W's—WHO, WHERE, WHAT—

WHO? Give your name: "This is Scout Joe Brown of Mansville." WHAT? Tell what is the matter: "I am reporting an automobile accident with three people seriously injured, one unconscious." WHERE? "Where Route 130 and Route 1 cross."

Be ready to answer questions about what first aid has been given and to receive instruction about what to do until help arrives. If you are on a hike or in camp, tell the doctor or the policeman where you will meet him to take him to the accident.

If for some reason you can't stay by the telephone until your call goes through, give the operator the necessary information.

By Foot or Bicycle. Sometimes you may not be able to get to a telephone, or the wires may be down because of storm or sleet, fire or flood. Then it is necessary for you to know the address of the nearest doctor, hospital, police or sheriff's office, so that you can go there yourself. Learn the locations and figure out in advance the quickest route by foot and by bicycle from your home, your troop meeting place, and your campsite.



FIRST AID

"Accidents will happen," they say. They shouldn't—but they do.

There may be many times in your Scouting life when you will come face to face with an accident. Out alone or with the gang, you may come upon a serious automobile smashup. Some summer day, you may have to save a person from drowning. In camp, a green Tenderfoot may cut himself with an ax or get stung by a hornet. On a hike, you or your pal may develop a blister or sprain an ankle. And at home, some member of the family may have a fall, or a child may swallow poisonous cleaning fluid.

In each case, you may be the one to give the necessary first aid.

It feels good to have a thorough knowledge of first aid. It is good to know that you can take care of yourself if you get hurt. But even more important, it is good to know that you are able to help other people who may be in trouble.

11b. 🐛 *Explain what first aid is and tell how to act in case of an accident.*

What Is First Aid? First aid is very definitely aid given *at first* in case of injury or sickness. That word "first" suggests that there is more to follow—the aid given by a person who has many years of training for the job—the doctor. Never play at "doctoring." If a case is at all serious, get a doctor.

To do a good first aid job, you must realize that there is more

"HURRY CASES"



Arterial bleeding needs to be stopped by immediate action.



Stopped breathing calls for application of artificial respiration.

to first aid than stopping bleeding or bandaging a wound. The way you act in an emergency has a great bearing on the patient's recovery. The *confidence* you show because you know what to do, the *common sense* you display in doing first things first, your *calmness* and *cheerfulness*—all these will make your patient feel at ease.

"Hurry Cases"

Most of the accidents you will come upon will be minor ones where you can take your time to plan and to act. But someday, you may be up against one of the "hurry cases" where life is at stake, where you have to move with utmost speed.

These are the "hurry cases"—

1. Blood is spurting or gushing from a wound—it must be stopped immediately.
2. Breathing has ceased—it must be started again by artificial respiration.
3. Poison has been swallowed—it must be made harmless.

JUMP TO THE JOB. A second saved may mean a life saved.

11c 🐦 Show how to handle "hurry cases" of arterial bleeding and stopped breathing, and tell what to do for poisoning by mouth.



Internal poisoning often turns out to be a matter of life or death.



Shock is always present in the case of an accident and requires care.

Severe Bleeding. A car crash, a railroad accident, carelessness with an ax or with a power tool—you rush to the scene, and there is a victim with blood spurting from a wicked-looking gash!

Grab at the wound with a bare hand and **PRESS—HARD!** Stop that blood! Then use your free hand to reach for your neckerchief or handkerchief or tear a piece off your shirt—or, if someone is near, call for a cloth folded into a pad or for a sterile gauze pad. Let go of the wound for the split second it takes you to slap the pad on it, then press again. Finally, tie pad firmly in place with some kind of bandage. If pad gets blood-soaked, don't remove it. Just put another pad on top of the first, and another bandage.

Then get the victim to a doctor or a hospital!

Usually, direct pressure on the wound will stop even the most severe bleeding. There is only one extreme case where it probably

SEVERE BLEEDING



In most cases, hand pressure directly on the wound will stop bleeding.



You can turn your Scout neckerchief into a bandage by folding it.

won't—where an arm or a leg is almost or completely cut off and where the artery gushes blood. In such cases—and **ONLY WHERE THE CHOICE IS BETWEEN LOSING A LIMB OR A LIFE**—you may have to apply a tourniquet.

To make a tourniquet, twist your handkerchief into a bandage about 2 inches wide. Wrap this bandage twice around the limb on the side nearest to the heart, leaving about an inch of skin between the wound and the tourniquet. Tie an overhand knot. Place a strong stick on the knot and tie it in place with a square knot. Turn the stick until the blood stops. Tie one end of the stick to the limb to keep it from slipping. Cover the wound with a dressing and bandage it. Note the time. Then get the patient under a doctor's care as soon as possible. Do not loosen the tourniquet—let the doctor do that.

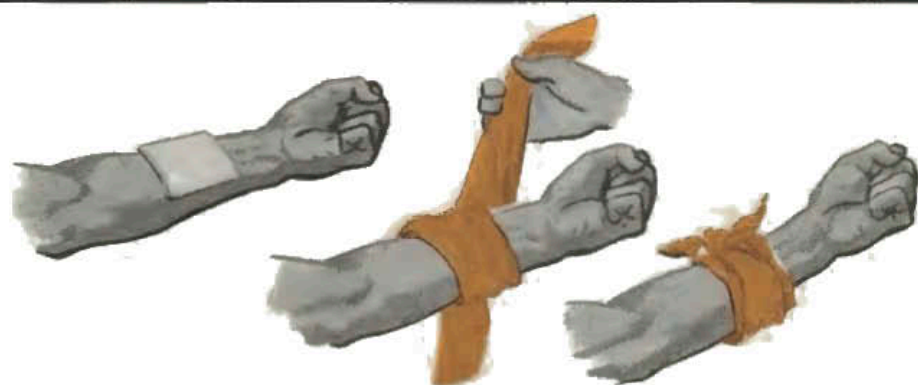

Cover the wound with a sterile dressing. Keep in place with bandage.

TOURNIQUET

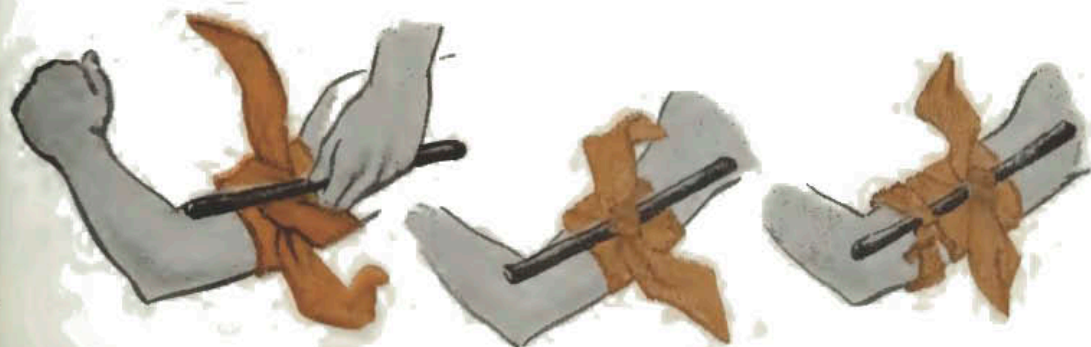

Learn to make a tourniquet—but use it only in case of dire emergency.

ARTIFICIAL RESPIRATION—Rescue Breathing

Artificial Respiration. A drowning person is pulled out of the water . . . a mechanic is dragged from under a car with its motor running . . . a child is pulled away from an electric wire. In each of these cases, breathing may have stopped. Yet the victim's life may be saved if someone gets to work right away giving artificial respiration. That someone could be YOU.

The most effective method of artificial respiration is **RESCUE BREATHING**. In this you breathe your own breath into the victim's



The head of an unconscious person slumps forward, and the base of his sagging tongue blocks the airway. The first job is to open up the airway. This is done by tilting victim's head back.

When victim's head is tilted back until his chin points almost straight up in the air and skin over his throat is stretched taut, the base of his tongue is raised off the back of his throat.



After head has been tilted far back, airway can be opened even more by pushing up the victim's chin—part way for mouth-to-mouth breathing, the whole way for mouth-to-nose breathing.

lungs through his nose or his mouth or, in the case of a child, gently into nose and mouth both.

Time is of the utmost importance. Place the victim faceup. If there is foreign matter (food particles, blood) visible in his mouth, wipe it out quickly with your fingers. Tilt the victim's head back, pushing his chin up so that the skin is taut over his throat, and start breathing into him.

For *mouth-to-nose breathing*, hold the victim's mouth closed



TILT VICTIM'S HEAD FAR BACK!

Push his head backward with one hand on his forehead and pull his chin up with other hand.

GIVE RESCUE BREATHING!

Open your mouth wide and take a deep breath. Blow air into the victim through nose or mouth.



In *mouth-to-nose breathing*, breathe through victim's nose and close his mouth. In *mouth-to-mouth*, breathe through his mouth and close his nostrils. For a small child, breathe through both nose and mouth.

with your hand against his chin and seal your lips around his nose. Now, blow air into the victim until you see his chest rise. Remove your mouth and let the air escape from the victim's lungs while you take a deep breath. Then blow into his lungs again, and again let the air escape. Continue blowing about 12 times a minute for an adult, 20 times for a child.

For *mouth-to-mouth breathing* when victim's nose is obstructed, hold his mouth open with your hand on his lower jaw, seal your lips around his mouth, and blow as described above.

When the victim's breathing starts, time your efforts to fit his efforts to breathe for himself. Keep him lying down, and make him warm with blankets or other coverings. Get him under a doctor's care during the recovery period.

NOTE: In training for this method and in passing the test, it is not necessary for you to do the actual blowing. Learn and demonstrate the correct way of tilting the victim's head back, pushing the jaw up. Explain how you would clean foreign matter out of his mouth, place your mouth, and give rescue breathing.

Poisoning by Mouth. One third of all accidental deaths among children are caused by poisons. It is unbelievable what children will swallow: kerosine, turpentine, insecticides, rat poisons, ammonia, lye, furniture polish, nail-polish remover, pills and tablets from the medicine cabinet, weed killer from the garden supplies.

Your first thought if you find yourself up against a case involving poison is this: Dilute it! Dilute it!! DILUTE IT!!! Water!

POISONING BY MOUTH



Water and milk are the main remedies to use for internal poisoning.

Water!! Have a child drink half a glass of water immediately, an adult a full glass. Then more water. Or milk if you have it. Look around quickly to see what poison was swallowed and get a call in for a doctor, giving the name of the poison if you know it. If the instructions on the poison container tell what antidote to use, send someone for it immediately and use it quickly.

What else can you do while waiting for the doctor? In most cases, you should encourage vomiting by adding salt to the water or by putting a finger or spoon in the patient's mouth to induce gagging. But, if the poison is a strong acid or lye or kerosine, you don't want the person to vomit—the poison coming up again may further damage the food passages. For strong acids, give water with a teaspoon of baking soda per glass, then milk. For lye, give water with a tablespoon of vinegar per glass, then milk. For kerosine, give water, then milk.

Shock and Fainting

11d 🐿 *Demonstrate first aid for shock and fainting.*

Shock. Every accident is accompanied by shock—a sudden lowering of the vitality caused by pain and fear and loss of blood.

A shock victim is very weak. His face gets pale, his skin cold and clammy, his breathing shallow. He shivers from chills, may even vomit. He seems dazed, does not know what is happening

SHOCK



Whatever the accident, shock is present and requires first aid care.

about him. In serious cases he may lose consciousness entirely. Shock may come immediately with the accident, or soon after, or may even be delayed for several hours.

DON'T WAIT FOR SYMPTOMS TO SHOW—head them off! Take for granted in ANY injury that the patient will suffer from shock, and take care of it.

FIRST AID FOR SHOCK—Keep the patient lying down. If he has a head injury, keep him level, otherwise raise his feet on a pack-sack, a log, or whatever else you may have.

In cool weather, put enough blankets, coats, layers of newspapers, under and over the patient to protect him. If the weather is hot, do not cover him. The idea is not to make him warm, but to prevent him from getting cold.

If your shock patient is conscious, let him sip a little water. If he is unconscious, do not attempt to force a liquid between his lips—it may choke him.

Fainting. Fainting is a “blacking out” because of a nervous condition. It may occur when a person has a sudden fright, has received bad news, has been standing on his feet too long, is sick to his stomach or suffering from hunger, is overtired, has been breathing bad air, and for any number of reasons. His face gets pale because the blood supply to the brain has decreased. He may start to wobble, or may suddenly fall to the ground.

FAINTING



When a person feels faint, have him sit down with head between knees.

FIRST AID FOR FAINTING—The best first aid is prevention: If you see a person getting pale and have the idea that he is about to faint, have him lie down. If this is not feasible, have him sit down and bend forward with his head as low as possible between his knees to get the blood back to the brain. Keep him quiet for a few minutes, then let him straighten up to see how he feels. If you ever feel faint yourself, care for yourself the same way.

If a person falls in a faint before you reach him, keep him down for several minutes. Loosen his collar. When he thinks he is feeling better, let him sit up. A little later, let him stand up. If he still feels faint, get him to lie down again until he is all right. A fainting person snaps back to consciousness as soon as he lies down. If he fails to come back, treat for shock and call a doctor.

Minor First Aid Cases

11e 🦋 *On yourself, show what to do for cuts and scratches, burns and scalds, blister on heel, bites or stings of insects and chiggers and ticks, skin poisoning from poison plants, sprained ankle, object in eye, nosebleed.*

Cuts and Scratches. Most of the first aid cases you will handle will be cuts and scratches. These are wounds—openings in the skin. Even the slightest wound should be given prompt care. Otherwise, germs may get to work and cause a dangerous infection. To prevent germs from doing their harmful work, clean out germs that may already have entered a wound and prevent others from getting in.

FIRST AID FOR SMALL CUTS AND SCRATCHES—The best way to clean a wound is to wash it with soap and water. At home, use water right out of the faucet. On a hike or in camp, use water from your canteen or the clear running water of a stream.

Wait until the skin around the wound dries, then put on an adhesive bandage. This consists of gauze folded into a small compress, attached to a piece of adhesive tape, and covered with two strips of protective material. Open up these strips to expose the compress, place the compress on the wound, pull off the strips, and stick the adhesive tape to the skin. If you have no compress

SMALL CUT



Wash a small cut with soap and water, let skin dry, then cover cut with an adhesive bandage. Soap is your best bet for cleaning a wound.

and the wound is small, wash it and let it bleed. The bleeding will stop shortly when the blood has clotted.

FIRST AID FOR LARGER CUTS—A larger cut should be washed with soap and water and covered with a gauze compress held in place with adhesive tape or with a binder. The gauze compress should be sterile—that is, treated so that it is free of germs. Be careful in taking it out of its envelope so that you do not touch the part that will cover the wound—handle it by a corner only.

IMPROVISE A STERILE DRESSING



LARGER CUT



Square knot

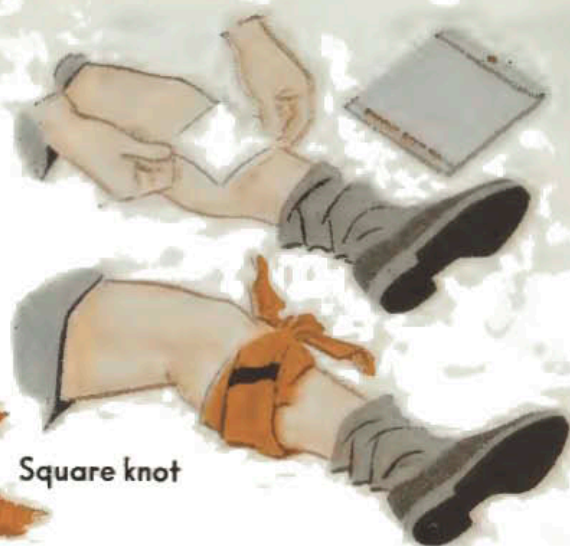

Wash a larger cut with soap and water. Cover with compress. Hold in place with adhesive tape or with a bandage tied with a square knot.

No sterile gauze compress? Very well, then use a piece of clean cloth, but sterilize the part of it that will touch the wound by scorching it as shown and described below.

The binder may be a gauze bandage from a first aid kit or you can use a Scout neckerchief folded up into a narrow band. Tie the two ends of the bandage together with a square knot as shown in illustration above. If a wound is at all serious, take the patient to a doctor as soon as possible.

11f  Show how to sterilize a dressing.

Improvising a Sterile Dressing. If you do not have a sterile dressing, you will have to improvise one. For this, fold a clean handkerchief or piece of cloth into a pad. Light a match and scorch an area of the pad large enough to cover the wound until the cloth has turned a dark brown. Even better, roast the cloth pad to a dark brown over a small bed of coals, holding it in the split tines of a forked stick (see illustration).

BURNS AND SCALDS



First-degree burn: The skin is reddened. Patient may feel pain. Sunburn is usually a first-degree burn.



Second-degree burn: Blisters have formed. Extreme care is necessary to keep the blisters from breaking and wound from being infected.



Third-degree burn: Some skin may be burned away and some flesh charred. This burn is very dangerous because growth cells that form the new skin are destroyed.

Burns, Scalds, and Sunburn. Someone grabs a hot pot handle or touches a burning coal—result: an ordinary burn. Someone knocks a pot of hot soup down over his foot or carelessly lifts the lid off a pot of boiling water—result: a scald. Someone falls asleep on the beach after a swim—result: a case of common sunburn.

FIRST AID FOR BURNS AND SCALDS—Burns and scalds are among the most painful of all injuries. When the burn covers a large surface you can be certain that shock will set in, so give first aid for shock as well as for the burn itself.

In mild burns and the usual form of sunburn, the skin gets red. These burns are called *first-degree burns*. Keep out the air and relieve the pain by rubbing a small amount of petrolatum, burn ointment, or cold cream on the red skin. If necessary, to prevent irritation, cover the ointment with a few layers of gauze or with a clean cloth.

If blisters form, you are up against a *second-degree burn*. This is considerably more serious than a first-degree burn because the blisters may break and become open wounds. Do not rub greasy ointment on blisters. Protect them by covering them with dry, sterile gauze. Keep the gauze pad in place with a bandage.

Third-degree burns are the worst of all. In these, the skin may be burned away and some of the flesh charred. Do not try to remove any clothing—it may be sticking to the flesh. Keep in mind that shock is certainly present. Wrap a clean sheet around the victim, cover him with blankets if the weather is cool, and rush him to a hospital.



Give first aid for shock. In third-degree burns shock may cause death.

BLISTER ON HEEL



Blister on Heel. A shoe rubbing against a heel may cause a blister. Stop for first aid as soon as you feel a blister forming.

FIRST AID FOR BLISTER ON HEEL—Wash the foot with soap and water. Then put an adhesive bandage on the heel if the blister is small, a sterile gauze pad if the blister is large.

If there is any chance that the blister may open accidentally, it is better to open it intentionally. Wash with soap and water. Puncture the blister near its edge with the point of a pin sterilized in a match flame. Then put on the sterile dressing.

BITES AND STINGS



Bites and Stings. Bites and stings of insects, chiggers, and ticks can be very painful. Some of them may cause infection.

FIRST AID FOR BITES AND STINGS—Bites of mosquitoes and ants, and stings of bees and hornets and yellow jackets cause pain because an irritating acid is injected into the flesh. To neutralize acid, dab with household ammonia or baking soda solution.

Chiggers are the larvae of a tiny mite. They can get onto your clothes and your skin when you walk through tall grass. They are so small you can't see them. They dig in, suck blood, and cause irritation. Ammonia and baking soda solution relieve itching.

SKIN POISONING



The hazard of skin poisoning from poison plants is greatest in the spring and summer when the sap is most abundant and leaves are out. But broken stems or roots may cause poisoning the year round.

Skin Poisoning From Poison Plants. The poisoning from poison ivy, poison oak, and poison sumac is caused by an oily substance found throughout the plants. The best way to keep from getting poisoned is to know these plants (see page 142) and avoid them. Yet, even with care, you may accidentally touch poison ivy. The skin may become red, itching. Blisters may form.

FIRST AID FOR SKIN POISONING—If you think you have touched a poison plant, wash immediately with soap and water, then wash with rubbing alcohol. Calamine lotion relieves itching.

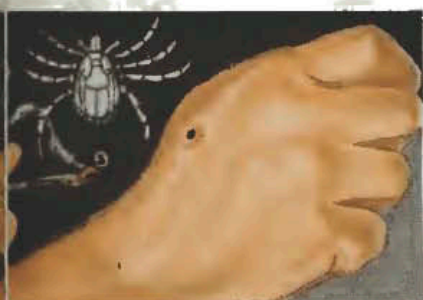

In case of a bee sting (far left), the bee will probably have left stinger in the wound. Remove the stinger carefully by scraping it out with a fingernail. Then dab wound with ammonia to ease pain.

Ticks are small, flat, hard-shelled relatives of mites. They can get on you in the woods or from your dog. They bite through the skin and suck blood. In certain areas, ticks may be infected with disease, such as "spotted fever." Therefore, don't take ticks lightly. The moment you feel a tick crawling on you, brush it off. If a tick has fastened itself to you, don't pull it off—the head will remain in your skin. Instead, cover the critter with grease or oil. This will close its breathing pores and make it let go. Or light a match, blow it out, and quickly touch the hot end to the rear of the tick to make it back out. Then wash with soap and water.

SPRAINED ANKLE



Sprained Ankle. A sprained ankle is often the result of a stumble or fall. It is painful and starts to swell immediately.

FIRST AID FOR SPRAINED ANKLE—Do not remove the shoe—if you do, the swelling may prevent you from putting it on again. Instead, use the shoe as a support and tie the special ankle band-

SOMETHING IN EYE

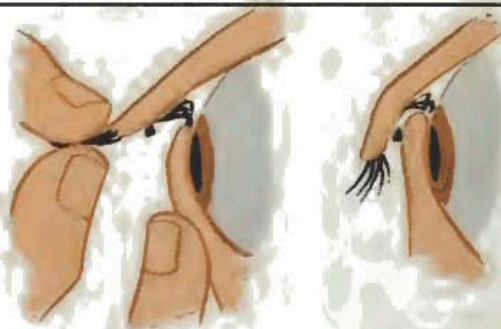
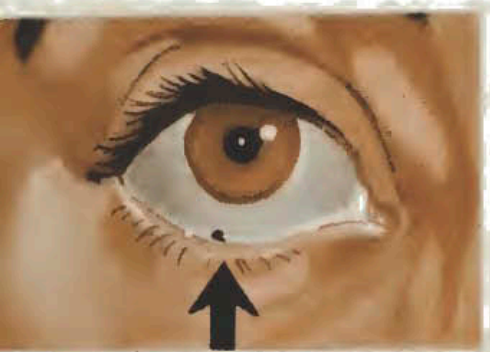

Something in the Eye. Any object in the eye is not only painful but may also endanger eyesight. It is usually easy to remove a grain of dirt from the white part of the eye, but any object on the clear front part of the eye requires a doctor's attention.

NOSEBLEED





age (see illustration) around leg and shoe both to keep the ankle steady. If the foot is bare, have the patient lie down; raise his leg and put a cold, wet towel around his ankle. If you have the slightest notion that the injury may be a fracture rather than a sprain, take no chances—get the patient to a doctor.

FIRST AID FOR OBJECT IN EYE—The first consideration is gentleness and cleanliness. The next is this: Do not rub the eye. Get the patient to blink his eyes—the tears caused by the irritation may wash the object to the inner corner of the eye from which you can easily remove it. If the object is under the upper eyelid, grasp the lashes of the upper lid gently between thumb and index finger and pull the lid out and down over the lashes of the lower lid—the edge of the lower lid may then wipe off the object. If the object is under the lower eyelid, place your thumb just below the lower lid and move it down gently, locate the object and remove it with the corner of a clean handkerchief moistened with water. If you do not remove the object, have the patient close the eye, cover with a sterile gauze pad bandage, and take him to a doctor.

Nosebleed. Bleeding from the nose is usually from a small vein in the middle partition of the nose. It seldom lasts long.

FIRST AID FOR NOSEBLEED—Sit up, bend the head back, press nostril on the side of the bleeding, or press the upper lip hard against the teeth with a finger. A cloth wrung out in cold water and placed over the nose also assists in stopping nosebleed.



SCOUT SPIRIT

You know the old saying "The proof of the pudding is in the eating."

Something similar holds true of a Boy Scout. The proof of a Scout is in the way he acts, in the things he does. Or to say it differently:

A real Scout is a fellow who **CAN** and **IS** and **DOES**.

The **CAN** is in the skills that people expect of a Scout. He *can* find his way in the woods, he *can* make a fire in a drenching rain, he *can* tie a knot that will hold, he *can* give first aid in an emergency—he **CAN** do a whole lot of things. That's the first part.

The **IS** is in the Scout Law: A Scout **IS** trustworthy, loyal, helpful, friendly, courteous, kind, obedient, cheerful, thrifty, brave, clean, reverent. A boy may be dressed in the complete, official Boy Scout uniform and yet not be a Scout—it is only if he actually **IS** all the things that are mentioned in the Scout Law that he is a Scout. The uniform alone does not make a boy a Scout—it is the boy inside the uniform that counts. That's the second part.

The two of them together—the first and the second part—spell out the Scout motto: Be Prepared. If a boy, for instance, **CAN** help and **IS** helpful, then he is truly prepared. The way he proves it is by his actions, by the fact that he **DOES** help.

The **DOES** is in the Scout Oath: "On my honor I will *do* my best. . . ." What a boy **DOES** shows what he **CAN** and what he

IS. At the same time, the more he DOES, the more he helps the CAN and the IS grow strong and trained and ready to show themselves in further action—which simply means that he is growing into a still better Scout, becoming a real man and a true citizen.

LIVING THE SCOUT IDEALS

12 🐿 *After completing the . . . tests, meet with your Scoutmaster (or an adult assigned by him) in a personal conference. At this meeting, complete to his satisfaction the following:*

a. Discuss your ideas about the meaning of the Scout Oath (or Promise), the Law, motto, and slogan: and give examples to show that you do your best to live up to these ideals in your daily activities.

Living the Scout Law. Honest now—have you done your best—your very best—to live up to the Scout Law to which you pledged yourself the day you entered the brotherhood of Scouting?

In your own mind, slowly go over each of the 12 points and ask yourself a few searching questions:

“Am I **TRUSTWORTHY**? Can I always be depended on? Do I always do what I promise to do? Have I proved myself **LOYAL**—to my parents, to my friends, to my patrol and troop, to my country?”

“Am I as **HELPFUL** as I might be? Have I done at least one Good Turn every day since I became a Scout—or have there been days when I have forgotten?”

“Am I naturally **FRIENDLY** to all, with a smile on my face and a helping hand? Have I proved myself a brother to every other Scout?”

“Am I truly **COURTEOUS**? Have I learned to do the many small courtesies that a gentleman does as a matter of habit—rising when a lady enters a room, giving my seat to an older person, making generous use of the little words “Please” and “Thank you”?”

“Am I **KIND** to animals and birds in general and to my dog in particular? Do I realize its needs and take care of them?”

“Am I OBEДИENT—doing the things I am asked to do promptly and in a spirit of real cooperation? Do I keep the laws of the land and the regulations of my community?”

“Do I meet and overcome difficulties with a CHEERFUL heart? Do I do my best to see the bright side of things? Do I do the tasks that come my way without grumbling?”

“Am I THRIFTY—not just in regard to money, but in the way I spend my time, the way I make use of my opportunities? Do I have a savings plan with promises for the future?”

“Have I shown myself BRAVE? Have I stood up for what I consider right rather than following the crowd? Have I accepted full responsibility for some mistake I have made?”

“Have I been CLEAN in my thoughts, my words, and my deeds? Do I turn my back on fellows who talk smut? Do I travel with a clean crowd?”

“Have I proved myself REVERENT by being faithful in my religious duties?”

Your Scout leaders have had a chance to find out about you from the way you act, from the way you work in patrol and troop. But only you and your God can truly know what kind of Scout you are—no one else can read your thoughts or look into your heart. That’s why it is important for you to set up your own high standards and do your utmost to live up to them.



Living the Scout Motto

The more Scoutcraft you learn, the better able you are to live up to the motto of a Boy Scout: BE PREPARED.

Someone has an accident—you are prepared to help because of your first aid training. A child falls in the water—you are prepared to save it because of the lifesaving practice you have had. A burning building—you are prepared to do what needs to be done.

Living the Scout Oath

I WILL DO MY BEST—For every day that passes the Scout Oath takes on a deeper meaning. Doing your duty to God and your country, living up to the ideals of Scouting, helping other people at all times become second nature. And as you go about sincerely doing your very best in everything you undertake, you grow into a true Scout, into the kind of boy you want to be.

PHYSICALLY STRONG—As a Scout you pick up new health knowledge and learn new skills to make and keep you physically fit. Hiking and camping with patrol and troop take you out in the open, strengthen and harden your body.

MENTALLY AWAKE—Scouting helps you be alert. It gives you a chance to develop your leadership ability. It challenges you to try your hand in many different fields—not just in outdoor crafts, but in numerous merit badge subjects—many open to a Second Class Scout.

MORALLY STRAIGHT—A boy gets to be a good citizen by practicing citizenship—by learning the importance of truth and honor, duty and justice, love of his fellowman, and by acting according to the high standards he has set for himself. Your Scout life takes you along the trail that leads from spirited boyhood to upright manhood.





MANY WAYS OF HELPING

- Raised school flag daily.
- Policed hill for sleigh riding.
- Acted as lifeguard at lake.
- Put out a grass fire.
- Wheeled crippled man to church.
- Dug post holes for neighbor.
- Got boy's kite down from tree.
- Did errands for sick lady.
- Cleaned trash off vacant lot.
- Gave first aid to burned child.
- Moved furniture for old lady.
- Picked broken glass off street.
- Found lost child.
- Splinted dog's broken leg.
- Helped man change flat tire.
- Delivered church circulars.
- Made scrapbooks for hospital.
- Reported live wire to power company.
- Helped blind man on bus.
- Sorted books in school library.
- Assisted fire department in drive.
- Took part in safety campaign.
- Put on first aid demonstration.

Living the Scout Slogan

The way you live up to your pledge to Do a Good Turn Daily shows the kind of Scout you are.

From the day the Scout movement started, people everywhere have come to know that Scouting stands for service to others.

Some of the services rendered by Scouts have been quick all-out efforts on a national scale. Others have required many hours of labor day in and day out.

Some have been spectacular—the part played by Scouts in great natural disasters like floods and hurricanes. Others have been small, kind acts hardly noticed—but adding up to a tremendous amount of help when done by every Scout everyday in every corner of our own country and around the world.

It is not the size of the Good Turn that counts—it is the way it is done—cheerfully and without a thought



of reward. And yet, you will find yourself richly rewarded for every Good Turn you do. Your reward will be in the knowledge that you have made life a little easier for someone else, in the inside happiness that comes from doing your duty.

There are dozens of things you can do for the family that will make life so much easier for your mother and father.

12b 🦋 *Describe several Good Turns you have done and explain how you think they helped others.*

Good Turns to Your Family. "Charity begins at home," they say. So does helpfulness. Your family comes first when there is a Good Turn to be done.

There are fellows who behave beautifully when out, but are pests at home—cutting up and expecting to have everything done for them. There are others who, at an early age, take a responsible place in the family and do their share—and often more than their share—without being told. Fortunately, most boys are in this second group.

As a Scout you will learn skills that will make you even better qualified to help at home than you were before joining. If someone in the family gets sick, you know how to get a doctor. If somebody has an accident, you can give first aid. If a package needs to be tied up, you volunteer to do it—you know the proper knot. If you see a safety hazard around your home, you take on yourself the task of eliminating it.

There are dozens of things you can do for the family that will make life so much easier for your mother and your father.

Good Turns to Your School. Schoolteachers know that they can depend on Scouts—not just for attendance on time and attention to duties, but also for special things that will benefit the whole school: safety work, first aid demonstrations, handling the school flag, leading games and athletics; and other events.

Your Scoutcraft training makes it easy for you to give much of this help. And the leadership you practice in your patrol and troop may help you develop into the kind of leader that your schoolmates will want for filling a student office and your teachers for taking on special responsibilities.

Good Turns to Your Church or Synagogue. Doing your part in your church or synagogue starts with knowing the teachings of your faith and living up to them in your everyday life.

Regular attendance in religious services is important. But make your attendance far more than just “being there.” Take an active part in the work of your church or synagogue. Set a good example for younger members and help wherever you can. Decide to earn the religious emblem of your faith (see pages 382-83).

Good Turns to Your Community. The baby toddling his first steps; the boy on his way to Scout meeting; the young man of 21, voting for the first time, are all American citizens. The crank who criticizes and tears down and does nothing for his community is a citizen—although a poor one. The man who tries to build up and better his community is a citizen—a good one.

Don't wait until you are a man to be a good citizen—be one as a boy.

The welfare of your community is placed in the hands of different departments: police, fire, health, street cleaning, parks, water supply, and several others. Anything you do to make their work more effective helps your community.

In addition, because you are a Scout, you may be called out with your patrol and troop in special community projects: Flag Day and Independence Day celebrations, Fire Prevention Week, and other observances.

The Story of a Good Turn

The way in which the Boy Scout movement came to America is one of the most perfect examples of the fact that it isn't the size of a Good Turn that counts—it's the doing of it, whether large or small.

It was in the fall of 1909. All day long the great city of London had been in the grip of a dense pea-soup fog. It had covered the city, had practically stopped all traffic, all business in the British capital.

An American publisher, William D. Boyce, from Chicago, Illinois, had trouble finding an office address in the center of the city. He had stopped under a street lamp to locate himself when out of the gloom a boy approached him.

"Can I help you, sir?" asked the boy.

"You most certainly can," said Boyce. "I wish you'd tell me how to get to this address. . . ."

"I'll take you there," said the boy, and led on to Boyce's destination.

An English Boy Scout helped William D. Boyce find his way through a dense London fog.



When they got there the American reached into his pocket for a tip, but before he had a chance to offer it, the boy said:

"No, thank you, sir, I am a Scout and a Scout does not take anything for helping someone."

"A Scout? And what might that be?" asked Boyce.

"Haven't you heard about the Baden-Powell Boy Scouts, sir?"

Boyce hadn't. "Tell me about them," he said.

And so, the boy told the American about himself and his brother Scouts. Boyce was very much interested and, after finishing his errand, had the boy take him to the headquarters of the British Boy Scouts. There the boy disappeared.

At the headquarters Boyce met Baden-Powell, the famous British general who had founded the Scout movement 2 years before. Boyce became so impressed with what Baden-Powell told him about Scouting that he decided to bring it home with him.

Scouting Comes to America. And so, on February 8, 1910, in Washington, D.C., Boyce and other outstanding men interested in boys founded the Boy Scouts of America. Ever since then this day has been observed as the birthday of American Scouting.

What happened to the boy? No one knows. He was never heard of again. But he will never be forgotten. In the International Boy Scout Training Center at Gilwell Park in England, there stands a beautiful statue of an American buffalo—a large-scale representation of the Silver Buffalo Award of the Boy Scouts of America.

The simple inscription on its base reads:

*"To the Unknown Scout
Whose Faithfulness in the Per-
formance of the Daily Good
Turn Brought the Scout Move-
ment to the United States of
America."*

One Good Turn to one man became a Good Turn to millions of American boys. Such is the power of the Good Turn. You never can tell. . . .





Baden-Powell founded the Scout movement
and gave it to the boys of the world.

The Founder of Scouting. What was it that had caught the imagination of this unknown English boy to such an extent that he was able to fire the interest of a stranger from a far-off country?

It was the game of SCOUTING as given to him and his British brothers by the man who, out of his genius and love for boys, had founded the Boy Scout movement—a man popularly known as “B-P,” the famous General Robert Stephenson Smyth Baden-Powell.

Baden-Powell was born in London, England, on George Washington’s 125th birthday—February 22, 1857—as the seventh son of Professor Baden-Powell. His father died when Robert was only three, leaving his mother to raise the large family.

As a boy, Robert lived an active outdoor life with his brothers and became a popular pupil at Charterhouse school. At 19 he joined the British Army and went to India. A few years later he was in Africa taking part in the campaign against the fierce Ashanti and Matabele warriors.

In 1899, B-P suddenly stepped into world fame.

Trouble was brewing between the British and the government of the Transvaal republic. Baden-Powell was directed to raise two regiments of mounted rifles and to hold Mafeking, a town in the heart of South Africa. War started, and Mafeking was immediately

besieged. For 217 days, B-P held the town against overwhelming numbers of the enemy, until British relief forces fought their way to his help on May 17, 1900.

Great Britain had been holding its breath through these long months. When the news finally came, "Mafeking has been relieved!" it went wild with joy.

It was as a great national hero that Baden-Powell returned to England. Here he found to his amazement that his personal popularity had given popularity to a book he had written for army men—*Aids to Scouting*. It was used as a textbook in boys' schools.

B-P saw a great challenge in this. If a book for men on scouting practices could appeal to boys and inspire them into action, how much more would a book written for the boys themselves!

He set to work to develop the idea of Scouting for boys. To make sure it would work, he took a group of boys with him to Brownsea Island, during the summer of 1907, for the world's first Boy Scout camp. And early in 1908 he brought out his handbook of training—*Scouting for Boys*. Instantly, Scout patrols sprang up in England and soon after in many other countries. By 1910 the movement had grown so large that Baden-Powell felt it necessary to sacrifice his army career to dedicate the rest of his life to Scouting.

The World Spread of Scouting. To his great happiness Baden-Powell saw the Scout movement becoming an international brotherhood. To strengthen this brotherhood, he called the Scouts of the world together for a "jamboree" in England in 1920. At this First World Jamboree, a cheering crowd of Scouts proclaimed Baden-Powell "Chief Scout of the World."

More and more countries took up Scouting. The day the movement reached its 21st birthday and thus came "of age," Scouting was found in practically every civilized country. On that occasion, B-P was honored by his king, George V, by being created a baron under the name of Lord Baden-Powell of Gilwell.

During the remaining years of his life, Baden-Powell traveled around the world to encourage the spread of Scouting. At 81, he went to Africa to spend his last days. There he died on January 8, 1941, and was buried in Kenya.

But the movement he founded continues to grow and to help boys become good citizens of their own country and of the world.

Good Turns That Make Scouting Possible

It took one Good Turn to bring Scouting to the United States. It took Good Turns by the thousands to build the Boy Scouts of America into the largest youth movement in the free world. It takes thousands of further Good Turns, done day in and day out, to keep Scouting going and to keep it growing.

Good Turns to Your Troop. The troop to which you belong exists because of the Good Turns of a great number of people.

The people of the church or organization that sponsors your troop believe in Scouting. Because of this they provide meeting space, heat, and light, and often make special contributions toward your troop's activities. The members of your troop committee assist your leaders and help make possible your own advancement through boards of review. Your Scoutmaster and the other adult leaders of your troop labor cheerfully and enthusiastically to provide the best possible Scouting experience for you and your friends. Just imagine how much all of this would amount to in dollars if you and your pals had to pay for all these services.

All that is expected of you in this respect is that you keep up your troop dues that help take care of running expenses, and that you work with the other boys in the troop in the money-earning projects that may be necessary to secure the equipment your troop needs to do effective Scouting.

Your Local Boy Scout Council. Scouting moves forward in your community because of the efforts and the contributions of hundreds of people—men and women.

Your local Boy Scout council is responsible for the expansion of Scouting within your community, for training the leaders, for



"Scout Tribute" in the nation's capital honors all those who have helped Scouting.

developing and running camping facilities, and many other things. A great number of people are involved in planning and carrying out these many responsibilities.

But work alone is not enough. To accomplish all that needs to be done, financial assistance is necessary. This is provided through your local united fund or community chest to which people of your community—including your parents—contribute, through fund-raising campaigns carried out by Scout-interested people, and through special gifts by friends of Scouting.

Your National Council. The National Council is responsible for the functioning of the Boy Scouts of America. This body consists of more than 5,000 distinguished citizens who, as volunteers, give their time and efforts—and often their money as well—to carry forward the work of the Boy Scouts of America. The National Council governs the movement through an Executive Board which, in turn, elects the Chief Scout Executive and expects him to be responsible for the actual operation of the movement. The Chief Scout Executive appoints the members of the national staff and directs their work. The national office is located at New Brunswick, N. J. So is the Johnston Historical Museum with its exhibits depicting the history of Scouting.

The annual registration fee of 50 cents paid by you and every other Scout and the \$1.00 fee paid by every adult member go to the Boy Scouts of America to make its far-reaching work result in better Scouting for yourself and all present and future members of the Boy Scouts of America. It makes possible the services of men who develop the programs of Cub Scouting, Boy Scouting, and Exploring and plan and administer big national events, such as our national jamborees. It finances the services of numerous specialists who produce the books and pamphlets and magazines of Scouting, who design uniforms and develop equipment, who give guidance in camping and special activities, in health and safety features, in volunteer and professional leadership training.

Scouting is paid for in many different ways. It is paid for in money and time and effort. But more than anything else: It is paid for in the dedication and active support of all those who believe in its ideals and in the effectiveness of its program in helping make a better America and a better world.

YOUR NEXT STEP IN SCOUTING

In finding your way by map and compass on a Second Class hike, you started by laying out your complete route in advance on your map. Then, in the field, you took a bearing, hiked a lap of your route, took another bearing, hiked another lap, and so on, until you reached your destination.

If you are smart, you are already using this same method to carry you forward to your desired goal in Scouting.

12c 🦋 *Look over the tests for First Class and discuss how you intend to progress toward that rank.*

The Trail Ahead. So far, you have been "hiking" the Second Class lap of your Scouting route. The First Class lap is immediately ahead of you.

Study the description of how to become First Class on pages 228-29 and the tests on pages 230-33 in the same way that you would study the route on a map. Next, take your advancement "bearings" by setting dates for yourself for passing the different tests. Then move ahead.

That's the way to get on in Scouting.

That's the way to get on in life.

More fun and excitement, more fellowship and more opportunity for personal growth await you as you move onward toward the rank of First Class Scout.

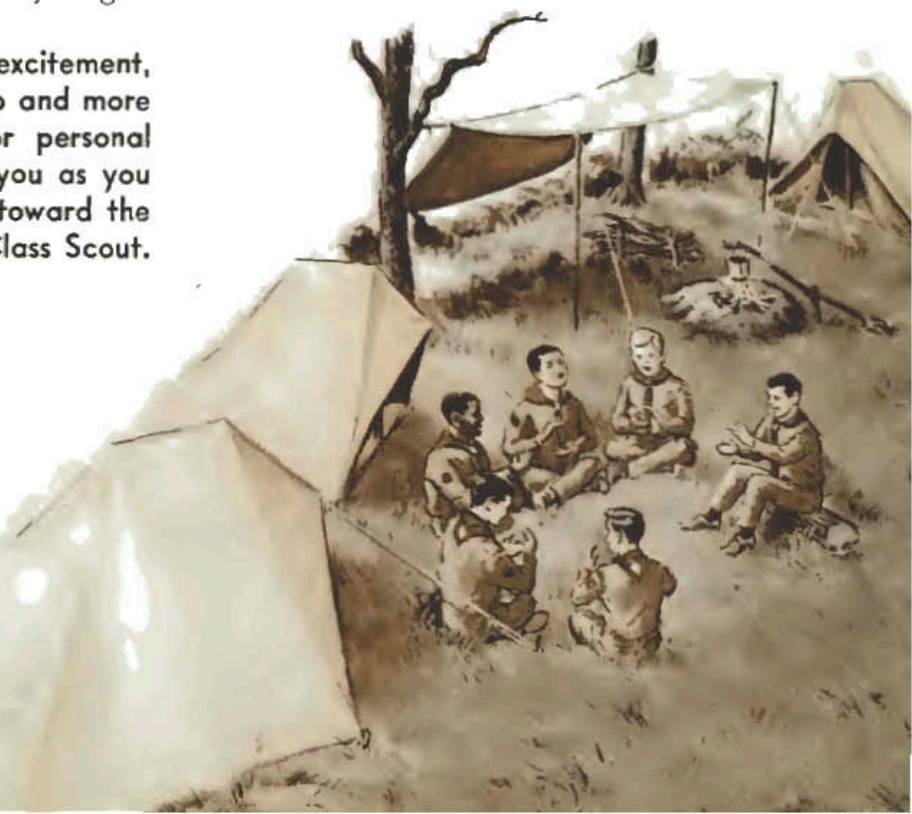



ADVENTURE HIKES AND GAMES

The old Vikings who set foot on the American continent long before the days of Columbus ate bear meat for strength. It was tough to chew and full of red blood. There's another kind of "bear meat" that'll make you strong—an imaginary kind, the kind you "eat" the last couple of miles of the 20-mile hike, the kind you "chew" when you fight your way through the brambles on a cross-country race, when you climb to the summit of a mountain. Cook up for yourself as much of that kind of "bear meat" as possible, and get in with the patrol and the troop on much more. As a Second Class Scout you're ready for it.

Most good Scout troops have an outdoor experience every



There is plenty of excitement in store for you when you go hiking with your patrol and your troop.



month—sometimes a hike, sometimes a camp. Some of these troop and patrol hikes will be built around a “big idea” in some Scoutcraft line. Others will be for testing your ingenuity or endurance. Still others will be in the form of games—but games with a purpose—to make you a better Scout, strong in body and alert of mind.

Let’s take a look at some typical troop and patrol hikes.

Treasure Hunt. At the end of a troop meeting, the senior patrol leader announces: “Next week’s hike is a treasure hunt!”

Immediately you think of pirates on the seven seas, of Captain Kidd and his men, desert islands, faded maps, and hidden clues. There may not be any desert islands where you live—but a treasure hunt is thrilling nevertheless.

This is the way it may work out: Your patrol leader gets a sealed envelope. On the front of it is a small sketch map with an *X*. Under the map is written, “Proceed to spot marked *X*, then open envelope.” The spot is easily located. Your patrol leader

IDEAS FOR PATROL AND TROOP HIKES

Adventure Hike

Exploration Hike

Collecting Hike

Tracking Hike

Mystery Hike

Knot Hike

Historical Hike

Father-and-Son Hike

Compass Hike

“North Pole” Hike

Conservation Hike

Treasure Hike

Signal Hike

Flapjack Hike

10-Mile Hike

20-Mile Hike

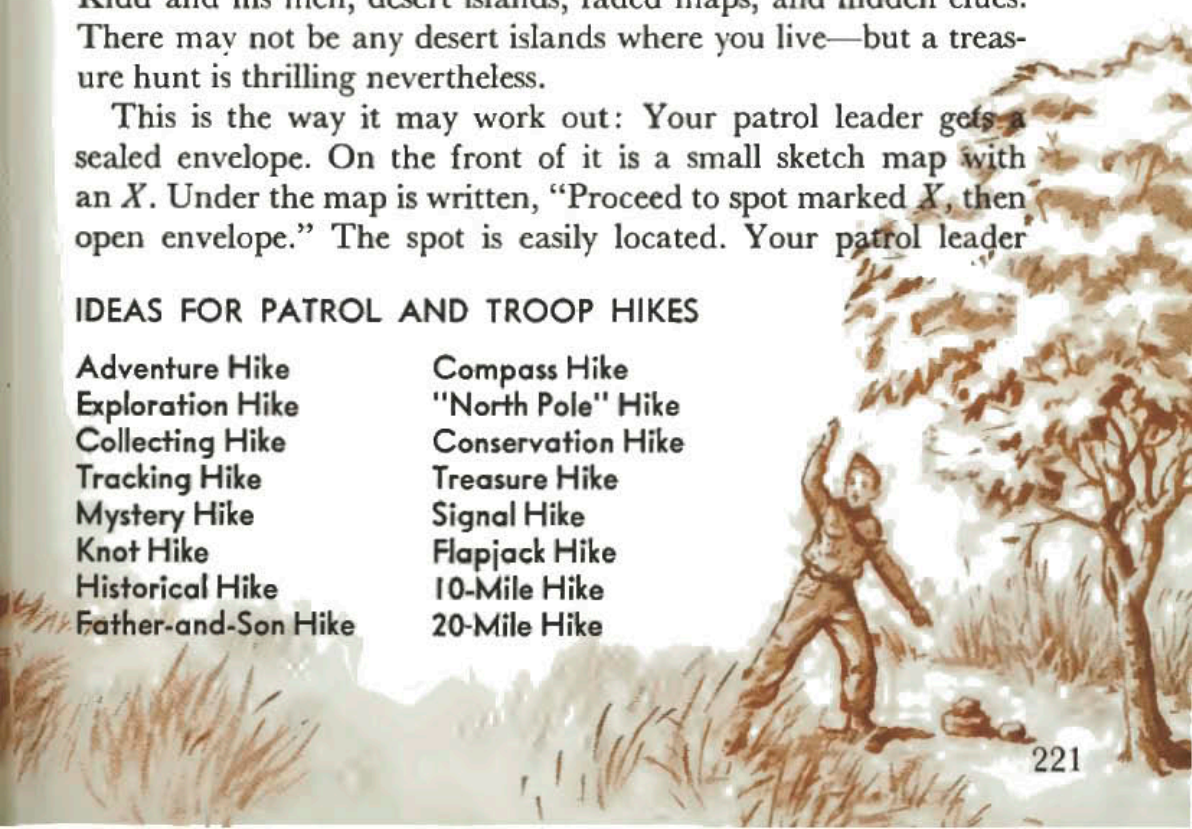

breaks the seal. In the envelope is a message: "Go to the tallest oak you can see from this point, then follow the direction of its biggest branch for about 200 feet." You do and find—nothing. That is, not until one of the fellows yells: "Here's a stone that has been turned." Under it you discover the next clue: "235° to tree with unnatural fruit." You get out compass, find the bearing and proceed. The tree proves to be a hickory with several pine cones tied to its branches. At the foot of the tree starts a trail of Scout trail marks that lead to another tree.

No clue around! What do we do next? Someone looks up. High overhead, a tag is tied to a branch. The patrol's best climber goes up for it. The tag says, "Look 175°!" Well, what do you see? "Looks like a red neckerchief in a tree about 500 feet away!" Off at a gallop! There's a clue attached to the neckerchief: "Now 400 feet, 95°." Here you find a pile of stone, and under them the last clue: "Dig below the dead chestnut!" You locate the tree, dig under it where the earth was recently turned and find—well, maybe not a chest of gold doubloons or pieces of eight, but certainly at least a box of peanuts to be divided among the lucky treasure hunters.

Unless—and that could happen—you find a slip of paper saying, "Fooled you! Fox patrol," left there by another patrol arriving on the spot first from another direction.

Lost Child Hike. The whole troop is alerted. Your patrol rushes to the mobilization point. When all the patrols are on the spot, one of the troop leaders steps to the front.

"A child is lost," he says. "A search has been going on all night. The only place that has not been scoured is a stretch of woodland, indicated on a map sketch which each patrol will receive. Our help has been requested. Are you ready to give it?"



Of course you are! Here's your chance to learn how such a search is done. In this particular case, the "child" is a life-size doll, made up of pillows and child's clothing—but some other time, it may be a real child.

Your patrol leader tells you what he expects you to do, and you are on your way, with orders to meet at a certain spot at a certain time whether you have found the "child" or not.

Nature Hunt. Someday, your troop may turn a hike into a nature hunt—combining observation with a knowledge of plants and animal life.

Each patrol leader is given a message to read to the gang:

Greetings and salutations:

Believe it or not: Our assistant Scoutmaster has fallen desperately in love, but—the fair lady won't even look his way. He will pine away unless he drinks a dose of my patented falling-out-of-love potion. For this I shall need the following ingredients—and mind you, you must bring me as many of them as possible within one hour:

Four acorns

Eighteen pine needles

Twenty dandelion seeds

A feather, at least 2 inches long

Six inches of sassafras branch

A bit of rabbit fluff

Three red cedar twigs

The shed skin of a snake

Good luck and good hunting. You may be assured that a potion made from these ingredients will do the trick.

(Signed) HOOD-DOO, *Witch Doctor*

To work immediately! The patrols are given the exact time for returning, and they get going. The gang that brings back the largest number of items within the time limit wins. Fun? Betcha!

Capture the flag. On another hike, one of the main events may be a few turns of a game called CAPTURE THE FLAG.

In this game, the troop forms two teams, two patrols to a team. Each team has its own territory. The territories are separated by a boundary line such as a brook or a trail.





The teams assemble close together at a starting point near the center of the line, each team on its own side of the boundary line. On a signal each team proceeds to set up a signal flag inside its own territory, within 200 steps of the starting point.

Another signal starts the game. The object now is to enter the enemy's territory, capture his flag, and carry it across the line into home territory without being caught. Scouts may be posted to guard the flag, but must not get nearer than 50 feet of it, unless an enemy breaks through to the flag. Then they may follow him.

Any Scout found in the enemy's territory may be captured by catching him and holding him long enough for the captor to say "Caught, caught, caught!" When a Scout is captured he must go with the captor to the "guardhouse"—a tree or rock 20 feet from the boundary line.

A prisoner may be released by a member of his own team touching him, provided the prisoner at the time is touching the guardhouse with a hand or a foot—whereupon both return to their own territory. If the rescuer is caught by the guards before he touches the prisoner, he, too, must go to the guardhouse. A rescuer can rescue only one prisoner at a time.

If a raider captures the flag but is caught before he reaches home, the flag is set up again at the point where it was rescued and the game goes on as before. If neither side captures the enemy's flag within the time agreed upon (say, half an hour) the game is won by the team with the most prisoners.

Wide Games. A "wide game" is something like CAPTURE THE FLAG—only far more elaborate and far more thrilling. It takes in a considerable amount of territory and occupies several hours of a hike—maybe a whole day or even a night.



Instead of being just Scouts, you're Indians on the hunt for scalps, prospectors on the search for uranium, border police out to get the smugglers, G men after bandits, a commando unit landing on an enemy shore, a rocket crew landing on Mars.

Everything you've learned in Scouting comes into play. There's use of compass and map for finding your way. There's stalking as you try to ambush an oncoming team of "robbers" or "pirates" or "Martians" . . . as you move stealthily toward them . . . hardly daring to breathe . . . taking advantage of the least bit of cover you can find. There's concealment, camouflage, maybe even disguise. You need initiative, physical fitness, courage.

Orienteering. A **BEELINE HIKE** is your first step in mastering the skill of orienteering. Get out your topographic map and decide on a starting point and destination about 3 miles apart. Draw a line from starting point to destination and set the bearing of the direction on your compass. Take off and follow your compass bearing right smack through the countryside overcoming all obstacles. Each boy takes a turn leading the gang.

When you have become good at beeline hiking, challenge another patrol to an **ORIENTEERING RACE**. Get someone familiar with the countryside to lay out a course by marking five or six points on a map and setting up a control station with an older Scout as a judge at each one. Then divide the patrols into buddy teams. Each team has a Pathfinder compass and a map with the control points indicated. Teams are sent off 10 minutes apart.

Set the compass for the first control point and get going. When the point is reached, reset the compass for the next point. Continue this way until the course is covered. Now find out which team has made the best time with all control points passed.



**ON THE CAMPING TRAIL TO
FIRST CLASS**



MY FIRST CLASS SCORE

<input type="checkbox"/>	/ 19.....	Active Service	234
<input type="checkbox"/>	/ 19.....	Camp Preparation	240
<input type="checkbox"/>	/ 19.....	First Camp	248
<input type="checkbox"/>	/ 19.....	Second Camp	252
<input type="checkbox"/>	/ 19.....	Backpacking	251
<input type="checkbox"/>	/ 19.....	Cooking	261
<input type="checkbox"/>	/ 19.....	Lashing	275
<input type="checkbox"/>	/ 19.....	Mapping	278
<input type="checkbox"/>	/ 19.....	Stars	284
<input type="checkbox"/>	/ 19.....	Trees and Shrubs	288
<input type="checkbox"/>	/ 19.....	Edible Plants	292
<input type="checkbox"/>	/ 19.....	Swimming	296
<input type="checkbox"/>	/ 19.....	Signaling	300
<input type="checkbox"/>	/ 19.....	First Aid	310
<input type="checkbox"/>	/ 19.....	Scoutmaster Conference	331
<input type="checkbox"/>	/ 19.....	Board of Review	



how to become a **FIRST CLASS SCOUT**

The purpose of the whole Scouting program is to assist you to become a good citizen, to help you grow into strong manhood. Every step along the advancement trail will lead you in this direction. The early steps put you on the road—but it is only as you take step after step that you can expect to reach the goal that Scouting is aiming for.

That's why you should strive to become a First Class Scout at the earliest possible moment.

Baden-Powell himself—the founder of Scouting—had this to say about the importance of becoming First Class: "A boy does not really get the full value of Scout training until he is a First Class Scout." And he gave the reason: "The tests for First Class Scouts were laid down with the idea that a boy who proved himself equipped to that extent might reasonably be considered grounded in the qualities which go to make a good, manly citizen."

What You Have To Do. By now you are familiar with the pattern of all Scout advancement. You know that for each rank you must show faithful attendance; you must have learned certain new skills; you must prove to your Scoutmaster and other troop leaders that you are doing your best to live up to the ideals of Scouting.

The closer you come to 100 percent attendance at all patrol and troop activities, the closer you get to showing that you truly intend to be **FIRST CLASS**. But your attendance alone is not enough—what counts most is what you do when you are there. There are younger boys, newer patrol members who look up to you now because they consider you one of the old-timers. Do you set an example for them? Do you accept patrol and troop responsibilities willingly and carry them out?

The Scoutcraft skills for the rank of First Class Scout aim to make you a good camper. There is nothing like camp for helping you grow “physically strong, mentally awake, and morally straight.” The vigorous activities of camp strengthen your body. Your life in the open teaches you to be self-reliant, resourceful—able to take care of yourself under all conditions.

The longer you stay in Scouting and the farther you advance, the more the ideals of Scouting influence your life. The Scout Law takes on a deeper meaning. The promise you gave in the Scout Oath becomes more and more important to you—you are not satisfied unless you truly do your very best, at home and in school, in your church or synagogue, and community.

Review and Award. You demonstrate your Scoutcraft skills to your patrol leader if he is a First Class Scout—otherwise to some other leader. When you do them right, he passes you in your tests. Your Scoutmaster and other troop leaders decide when you have met the necessary tests for attendance and Scout spirit. When they are satisfied that you are ready, your Scoutmaster arranges for you to appear before the troop board of review. This board, consisting of men interested in helping boys, makes certain that you have met all tests in a **FIRST CLASS** manner and approves you for advancement.

Soon after, at a troop court of honor, your Scoutmaster presents your First Class badge to you in front of your friends.

You are proud—you have a right to be. But also, you have a great obligation: With the First Class badge on your pocket, the whole Scout movement expects you to act like a **FIRST CLASS** Scout. Each of your brother Scouts expects you on your honor to **DO YOUR BEST**.



F I R S T C L

To become a First Class Scout, you must show by your attendance record that you have been active in patrol and troop meetings and activities for at least 2 months since becoming a Second Class Scout. While a Second Class Scout, do the following:

1. Tell what preparations to make, what equipment to take, and what kind of campsite to pick for a safe and successful camp.
2. (a) Take at least two camping trips of not less than 24 hours each with your troop, your patrol, an adult, or another Scout who is at least First Class. (b) Before each camp submit a camp plan for approval (unless this is a troop camp) to your Scoutmaster or an adult assigned by him. (c) Before leaving on each of these camping trips, present yourself for inspection suitably clothed for the locality, season, and weather and equipped for the occasion.

(d) On at least one of these overnight camps, carry on your back, for a distance of not less than 1½ miles, a pack containing your personal equipment and your share of common camping equipment and food. (e) Pitch a tent correctly and use it for shelter during your encampment. (f) Make a ground bed and sleep on it. After striking camp, repack your gear and



S T E S T S

carry it out at least $1\frac{1}{2}$ miles. (g) On each of these camping trips, follow proper sanitation practices and safety precautions and leave a clean camp.

(h) On at least one of these overnight camps, prepare from raw, dried, or dehydrated ingredients and cook over a fire in the out-of-doors a complete breakfast of fruit, hot cooked cereal, hot beverage, and bacon and eggs (or pancakes); and a complete dinner or supper of meat (or fish or poultry), vegetable, dessert, and bread (or biscuits or twist). (i) Clean up afterward, properly dispose of garbage and trash, put out your fire, and leave a clean camp.

3. Lash poles together with shear, square, and diagonal lashings.
4. Using compass and your step measurements, make a sketch map of an area approved in advance by your leader. Include map symbols indicating location of at least 10 landmarks, a north arrow, and scale in feet.
5. Point out in the sky the North Star and at least five constellations.



6. Identify in the field 10 different kinds of trees or shrubs. Describe the area where each was found and the usefulness of each to its surroundings or to animals or to man.
7. Find at least four different edible wild greens, roots, buds, shoots, nuts, or fruits. Prepare and eat one of them selected by your leader.
8. (a) Tell what precautions must be taken for a safe swim. (b) Jump feetfirst into water over your head in depth. Swim 50 yards. During the swim, stop, make a sharp turn, and resume swimming.
9. Send and receive a message of at least 20 words, using either international Morse or semaphore codes and necessary procedure signals.
10. (a) Show that you have retained your Second Class first aid knowledge by being able to demonstrate any of it asked for by your examiner. (b) Show how to use a triangular bandage for arm sling and as a binder for wounds on head, hand, knee, and foot. (c) Explain first aid for puncture wounds from splinter, nail, fishhook, dogbite, poisonous snakebite. (d) Describe how to recognize and care for victims of heat exhaus-



tion, sunstroke, frostbite. (e) Explain danger of taking laxative for a stomachache. (f) Demonstrate first aid for fracture of collarbone, upper arm, forearm, lower leg. (g) Tell under what circumstances an injured person should or should not be moved. (h) Demonstrate walking assist, one-man and two-man carries. (i) Improvise a stretcher and, with helpers under your direction, transport a presumably unconscious person.

11. After completing the above tests, meet with your Scoutmaster (or an adult assigned by him) in a personal conference. At this meeting, complete to his satisfaction the following:

(a) Discuss your ideas about the meaning of the Scout Oath (or Promise), the Law, motto, and slogan and give examples to show that you do your best to live up to these ideals in your daily activities.

(b) Describe at least one service project in which you have taken part since becoming a Scout and explain how you think it helped others.

(c) Discuss the adventure and vocational exploration of the merit badge plan. Look over the requirements for Star rank. Plan the next steps in your progress toward becoming an Eagle Scout.



YOUR LIFE AS A SCOUT

Have you ever seen a TV show or a movie of an Alaskan gold-rusher or an Arctic explorer or a Royal Mountie hitching up a dog team to a sled for a trek into the snowy vastness of the North? The dogs jump around him, barking, eager to go. One after the other they are hitched into position. "Mush!" The lead dog takes hold—and a moment later, dogs and sled and man have disappeared over the horizon.

If you want a real example of teamwork—that's it!

To accomplish anything worthwhile you need someone to decide the course, someone to set the pace, and everyone to swing into action. In Scouting, the Scoutmaster decides the course for the whole troop, each patrol leader sets the pace for his gang, and each patrol member does his part.

✚ *To become a First Class Scout, you must show by your attendance record that you have been active in patrol and troop meetings and activities for at least 2 months since becoming a Second Class Scout*

Your Life in Your Patrol. Undoubtedly you are already a good teamworker in your patrol. But the ordinary brand of team is not



sufficient. If you expect to reach First Class, your work in the patrol must be **FIRST CLASS**. It is not enough to do the things that come your way—a First Class Scout goes out of his way to do more than is expected of the average Scout.

Any Scout is expected to be present at every patrol activity—a First Class Scout comes to patrol meetings prepared with ideas to help the patrol. Any Scout is expected to do his part of the work in the patrol—a First Class Scout accepts special responsibilities and carries them through.

Give your patrol leader your full cooperation. If any of the activities of the patrol meeting calls for special equipment, be sure to bring it. If advance training is required, come prepared. When you have learned certain Scoutcraft skills yourself, help your patrol leader train new boys in those skills.

There will be times in any patrol's life when the going is rough—when a hike is a flop, when a patrol stunt "lays an egg," when a looked-forward-to camping trip is washed out. Those are the times when your team spirit is put to its severest test—but also the times when you have a chance to work with the gang to turn apparent failure into glorious success.

It is by taking "the bitter with the better" that you prove what kind of stuff you are made of.

Your Life in Your Troop. Three A's count high for showing how you are coming along in the troop: your *Attendance*, your *Appearance*, your *Attitude*.

Your attendance is probably excellent—you are there on the dot for all troop meetings, hikes, and camps. When sickness or

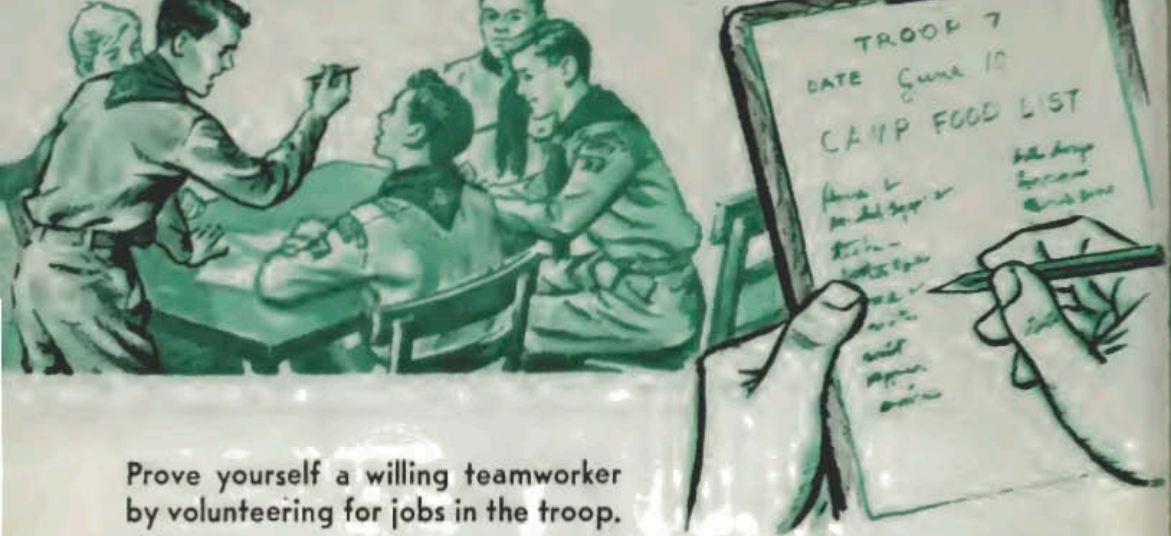

Prove yourself a willing teamworker by volunteering for jobs in the troop.

another serious reason prevents you from coming, you inform your patrol leader in advance so that he can announce "All present or accounted for" and can keep the patrol's attendance at the high level that it should be.

Your appearance—well, how about it? Do you always show up for Scout activities in a uniform that is neat and snappy and complete? Do you wear your badges correctly? You can hardly be expected to be taken for a First Class Scout unless you look like one.

Your attitude shows in everything you do during your attendance in troop events—in the way you come to attention the moment a signal is given, the way you get set for a game or a contest, the way you take part in the program.

Your Scoutmaster gives his time and his effort and his best thoughts toward making the troop as good as possible. He should be able at all times to count on each of "his boys" to be his right-hand helpers—not just taking an eager part in all scheduled activities, but also doing the many chores that are necessary in running a good troop: getting out equipment, putting away equipment, straightening up the meeting room, clearing a campsite, helping "run the show."

By being ready for anything that happens in the troop you will come close to the high standard that your Scoutmaster has a right to expect of a prospective First Class Scout.

But also, by giving Scouting the very best that is in you you'll get the most out of Scouting for yourself.



For a worthwhile service project, become den chief for a group of eager Cub Scouts.

Taking Part in Patrol and Troop Projects. Active patrols and troops always seem to have half a dozen special projects going on. Some of these have to do with taking part in district and local council events. Others involve service ranging all the way from paying visits to the local children's hospital to improving the town's watershed by planting trees.

In addition to taking part in such projects there's another kind of service you can do on your own: the service of leadership. By taking advantage of the chance you have in Scouting to become a leader, you will help others and, at the same time, develop your leadership ability.

Some of the leadership opportunities in Scouting you can seek—others may seek you. If you have interests along certain lines, you may offer your services to the troop as troop scribe or troop quartermaster or troop librarian or whatever troop positions are open. If there's a Cub Scout pack connected with your troop, you may become a den chief and help a group of eager, young boys have a good Cub Scouting experience.

If you prove yourself the right kind of fellow with real leadership ability, the boys in your patrol may, some day, elect you patrol leader. That is one of the finest tributes that can be paid a boy—to be accepted by a group of boys as their leader. The job of patrol leader carries with it great responsibilities—but also great satisfaction. You will get a real thrill out of working to turn a gang of boys into a real patrol, to help five or six or seven fellows become real Scouts.



TO CAMP!

Camp! There's a word that's filled with adventure for every real boy! Camp stands for freedom, fun, and adventure!

Camp! Just breathe the word—and immediately you think of a tent under the open sky, of bacon sizzling in the pan, of days full of excitement, of sitting with your best friends at night around a blazing campfire.

Camp is the high spot of your free and happy Scouting life. You'll learn more about Scouting in a few days in camp than it is possible to learn in months in the patrol den or the troop room.

Out in camp you'll have a glorious time—but you'll do more than that. You'll build up your health and your strength. You'll learn to be resourceful, self-reliant. You'll deepen your love of nature—of our wonderful country with its marvelous natural resources. You'll learn to get along with others, to do your share in the patrol for the common good.

To get the greatest benefit from camping you need to be a good camper. It's the good campers who have the most fun in camp. To them, each camp is a success—whether the sun shines or the rain pours. There's work in making a camp successful—but then, everybody works. And there's real joy in it, too—because when each member does his share of the work it means that everyone has time for his share of the fun, too. You'll come home from each camp with a stronger patrol spirit and with more Scouting knowledge for yourself.



Camping with the patrol—
that's the life! In a good
patrol you have the chance
to become a good camper.



You'll have fellowship
and fun when you are out
camping with the patrol.

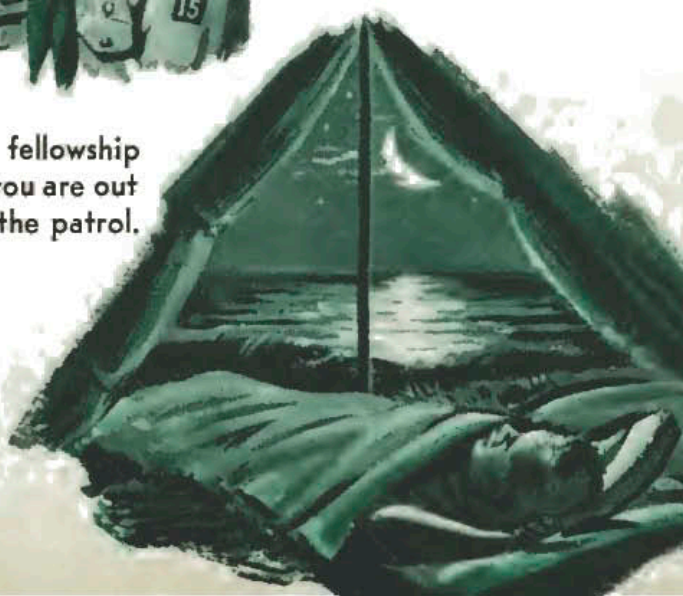

And for every camping experience you have, you'll want more and still more—there'll be no holding you back. You'll want to become a year-round camper, an all-kinds-of-weather camper. You won't become that kind of camper by simply going out in the open with a tent and expecting to eat and sleep and have a good time. You'll have to do some intelligent preparation in advance to have a successful camp.

1 🌿 *Tell what preparations to make . . . for a safe and successful camp.*

Prepare for Camp. You have already begun your preparation for camp on the hikes of your patrol and troop. The safety precautions you take in hiking fit into camping as well. The steps for building a fire and cooking a hike meal lead directly into camp cookery. Your Second Class axmanship comes into play in making camp. In addition to these skills, you will be preparing yourself for camp by getting together the necessary equipment, by practicing tent pitching at home, by looking for suitable campsites on the hikes you take.

With all this preparation behind you, you will have no problem making yourself comfortable under canvas. You will be well on your way toward becoming an all-round camper.



EQUIPMENT FOR SCOUT CAMPING

1  *Tell . . . what equipment to take . . . for a safe and successful camp.*

Personal Camp Gear. When lining up your personal camping equipment, think ahead, "What do I really need?"

First of all, for a good camping experience, you must sleep well. To do this, you must be warm and comfortable. For warmth, bring along one to three blankets or, even better, a good sleeping bag. For comfort, you can turn a straw tick of light cloth into a mattress by filling it with dry leaves or grass, or you can use a lightweight air mattress. For insulation against the moisture of the ground, plastic ground sheet is important. For night wear, bring pajamas.

You want to eat. Here you'll need knife, fork, and spoon; plate, cup, and bowl.

You want to be clean. So bring soap (in a plastic container) and washcloth, toothbrush and toothpaste, comb and metal mirror, hand towel and bath towel, and perhaps, a plastic wash-basin. For washing clothes, carry detergent in a small plastic bottle. If you expect to go swimming, take trunks along. If your camp is to last for several days, you'd better have extra underwear, stockings or socks, handkerchiefs, and spare uniform parts.

You want to be prepared. Clothes may rip, stockings may wear, so put in your pack a repair kit, with needles and thread, safety pins, buttons, and a pair of spare shoelaces. A flashlight, a pocket-knife, and a small individual supply of toilet paper are three other preparedness items.

You will want to carry with you the Bible, Testament, or prayer book of your faith, and probably also this handbook. Finally, if you are like most campers you have a few pet items you can't get along without—watch, camera, canteen, drinking cup, compass, songbook, air pillow, musical instrument, or whatnot.

Your Pack. To get your gear to camp, you'll need a pack that is strong but light, waterproof, provided with broad straps for easy carrying and large enough not only to hold your own equipment but also the share you have to carry of the patrol equipment.



PERSONAL CAMP EQUIPMENT

- Pack
- Blankets (2 or 3) or sleeping bag
- Air mattress or straw tick
- Waterproof ground sheet, plastic
- Sweater or jacket
- Poncho or raincoat
- Pair rubbers, lightweight
- Pair moccasins or sneakers

Clothesbag(s) containing:

- Extra uniform parts
- Pajamas Swim trunks
- Extra handkerchiefs

Toilet kit containing:

- Soap in container Washcloth
- Toothbrush Toothpaste
- Comb Metal mirror
- Washbasin, plastic or canvas
- Hand towels Bath towel
- Laundry materials (detergent)

Eating kit containing:

- Knife Fork Spoon
- Plate Cup Bowl

Repair kit containing:

- Needles Thread Buttons
- Safety pins Shoelaces
- Individual toilet paper
- Flashlight
- Scout knife
- Boy Scout Handbook
- Bible, Testament, or prayer book—according to your faith

Extras You May Want To Take

- Watch Camera Films
- Notebook Pencil Pen
- Drinking cup Canteen
- Musical instrument Songbook
- Purse or wallet Air pillow

Make a check mark with a pencil in each square as you lay out your equipment for camp.

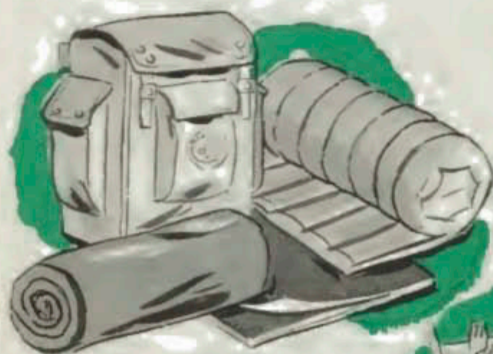

Patrol Camp Equipment

Tents. When you think of camping, in most parts of the country you think of tents.

If you are a member of an old patrol in a troop of real campers, your patrol or troop will probably have enough tents to go around for all the fellows. If you are in a new patrol, help the troop and the gang—and yourself—to get the tents you need.

But what kind? Think ahead.

You'll want tents that are suitable for overnight camps the year round and for a long summer camp—that means lightweight to mediumweight tents. You'll want tents that are roomy, with a ground surface of approximately 30 square feet per camper and with a height that won't cramp you—so your best type is a two-boy tent around 7½ feet by 8 feet, about 6 feet high. The official Boy Scout tents meet these specifications. The Tarp, Overnighter, and Miner's tents are the lightweights for backpacking. The Explorer, Voyageur, and Camper are mediumweight tents.

The Explorer tent is one of the most popular of all Scout tents. It has a short ridge and can be pitched with one inside T pole or with a pair of outside shear poles. The Camper tent also has a short ridge. It opens with a front "porch" and is pitched with two poles. The Voyageur has a long ridge.

In your council's summer camp, you may be sleeping in a Wall tent that looks somewhat like a regular house, or in a Baker tent with an open front.

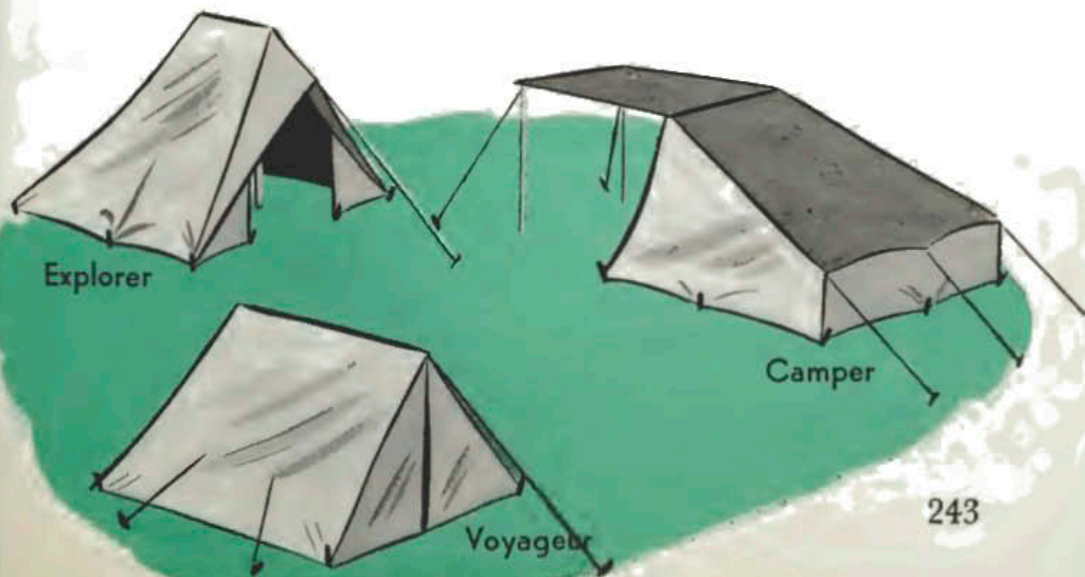

PATROL CAMP EQUIPMENT

TENTING CREW EQUIPMENT

- Two-boy tents (4), with poles and pegs
- Dining fly, 10 x 10 ft. minimum size, with poles, pegs, and guy lines
- Patrol flag on staff
- Ax
- Camp shovel
- Repair kit containing:
 - Mill file (8-in.) for ax sharpening
 - Sharpening stone
 - Twine Thin wire Needles
 - Thread Safety pins
- First aid kit
- Personal appearance kit containing:
 - Shoe polish Polish brush
 - Polish rag Cleaning fluid
- Toilet paper
- Electric lantern

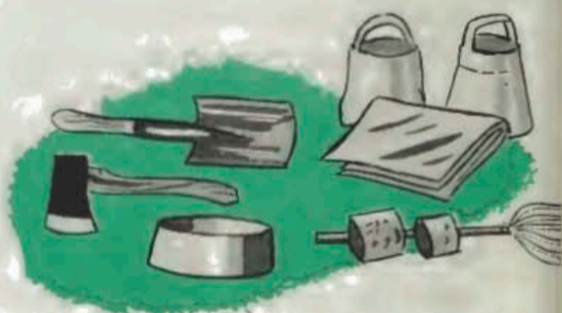
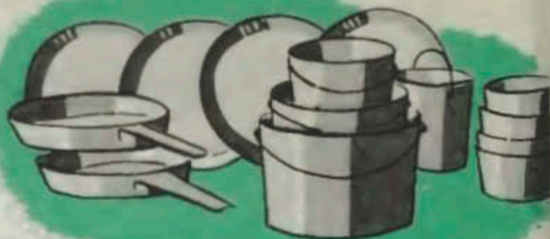

COOKING CREW EQUIPMENT

- Cook kit (Trail Chef Kit) containing:
 - Pots (4) Frying pans (2)
 - Serving plates (4)
 - Serving cups (4)
- Chef's kit containing:
 - Carving knife Spoon, large
 - Fork, large Ladle
 - Pancake turner or spatula
 - Potato peeler, "knee action"
 - Can opener Measuring cup
 - Sugar dispenser Salt and pepper
 - Match container, waterproof
 - Food canisters (plastic) with lids, various capacities—20 to 50 oz.
 - Plastic bags various sizes
 - Roll of aluminum foil
 - Roll paper towels
 - Plastic sheet
- Water pails (2), plastic or canvas
- Cleanup materials:
 - Dish mop Scouring pads
 - Roll processed cleaning cloth
- Ax
- Camp shovel
- Saw

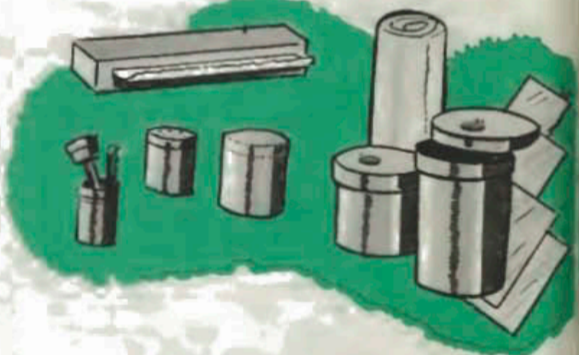

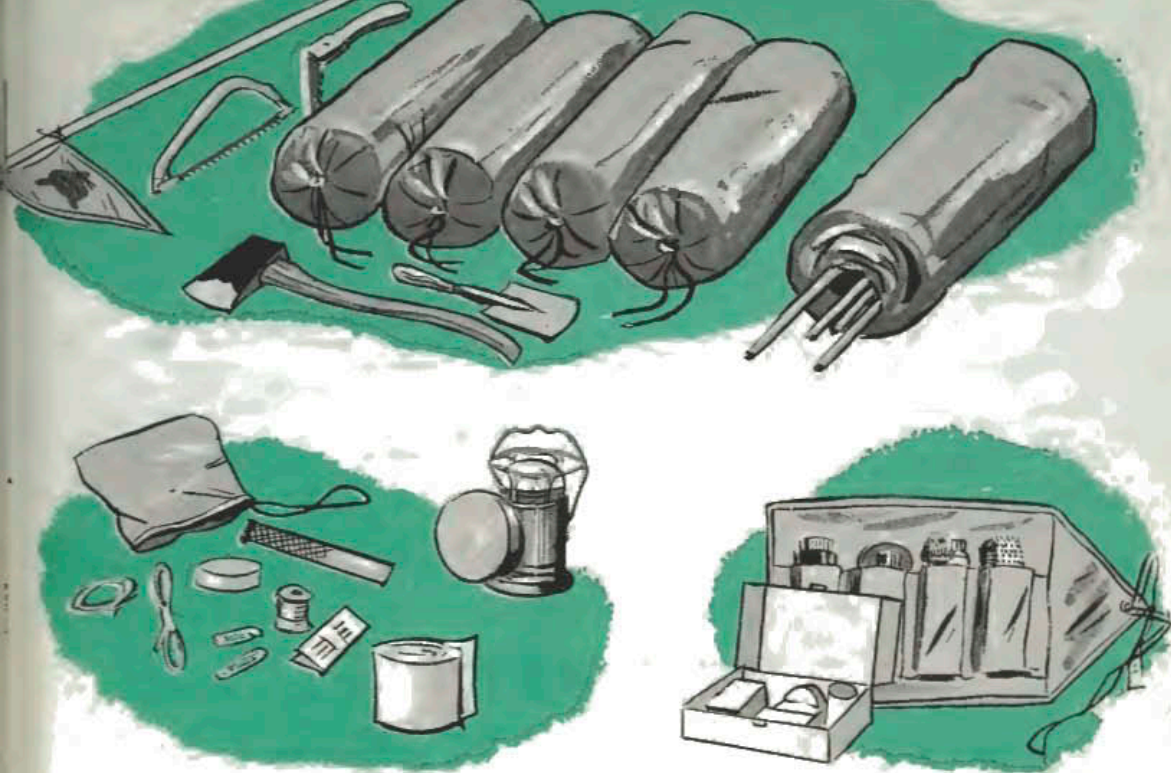

Other Patrol Camp Equipment. In most cases, you'll bring tent poles and tent pegs from home—although occasionally you may camp where you have permission to cut them on the spot. Tents are pitched with the help of strong guy lines.

For putting up camp, one or two hand axes and a saw will come in handy, so will a couple of camp shovels or spades.

For cooking meals for the whole patrol, your gang will need four pots and two large frying pans. A nesting set, such as the Trail Chef Kit, simplifies the carrying. You should also have a set of kitchen knives, forks, and spoons, a number of plastic bags and containers for your foodstuffs, and perhaps a folding pail—plastic or canvas—for getting water. For cleanup, you'll use a dish mop, scouring pads, and disposable paper towels.

Better bring along a repair bag with thread and needles, squares of tent material to repair possible rips, some wire and twine, a few nails, and a file and a sharpening stone for keeping your axes keen. You may also want a personal appearance kit, with shoe polish, polish brush, and polishing rag.

And then, of course, a first aid kit with the necessary items—no patrol goes camping without one.



YOUR CAMPSITE

1 🍄 *Tell . . . what kind of campsite to pick for a safe and successful camp.*

Where To Camp. Where are you going to camp? On the perfect campsite, of course. What makes a campsite perfect? Here are the points to look for:

The perfect campsite is a fairly open spot, elevated enough to avoid possible morning fogs that may rise from rivers or lakes to the neighborhood. The land is gently sloping so that rainwater drains off easily, yet it is level enough for comfortable sleeping. The soil is grass-covered, sandy, or gravelly to absorb the rain. Avoid—clay, because the grass that covers it will wear off quickly and rain will turn it into mud; loose sand, because this has a way of getting in everywhere, into your food and your clothes; rich vegetation of grass or brush, because this indicates damp ground and mosquitoes aplenty; poison ivy, for obvious reasons.

Your perfect spot will have shelter against the prevailing winds. Choose a site with trees or shrubs to the west and north, so that your tents are exposed to the sun during the early hours of the day. Don't put up camp directly under trees. They'll protect it during a heavy rain, sure—but when the rain is over they'll go on dripping all by themselves for hours after. Another disadvantage



about camping under trees is that dead branches may suddenly come crashing down on an unsuspecting camper.

There should be water within a reasonable distance—not just for drinking, but also, if possible, safe water for bathing.

Wood for fuel and for the camp improvements you'll want to make should be available in sufficient quantity.

So much for the campsite itself. Now let's have a look at the surroundings:

Your spot should be beautiful and far enough away from people to ensure privacy. If you have visitors running through camp at all hours of the day you'll have little chance for real camping. On the other hand, your spot should be close enough to your hometown to be reached without spending too much time and money on traveling.

Your spot should be safe. Don't pitch your camp in a gully—if you should have a sudden downpour you may be in danger of a flash flood. Don't camp under an overhanging cliff—you never can tell if a rockslide may occur. And don't camp in a tinder-dry forest if your area has been going through a drought period.

The perfect campsite is hard to find. Granted! There are sections of our country where the best spot available will have only a few of the good points mentioned. But keep your eyes open—you may come upon your dream spot on a patrol hike. Or your troop or your local council may have found the best possible campsite in your vicinity. When you have located the site, get permission to camp there and be sure to follow any restrictions the owner may insist on for its use.



YOUR FIRST CLASS CAMPS

You'll be learning the skills of Scout camping on the overnight camping trips of your patrol and troop. By listening to and following the advice of your patrol leader and the fellows in your patrol, you get to know what clothing and equipment to take, what site to select, how to build a simple fireplace, how to cook, how to stay healthy in camp. When you know these skills you will be ready to use them on two camping trips.

2a  *Take at least two camping trips of not less than 24 hours each with your troop, your patrol, an adult, or another Scout who is at least First Class.*

Making Your First Class Camps. You will have the most fun if you pass the test for your two First Class camping trips right in camp with your whole patrol. All the other fellows will be interested in seeing how well you make out. If your patrol does not have camps scheduled when you are ready to pass the test, get your Scoutmaster's approval to do the camping with a companion who can make a report on the way you did the job. This companion may be a buddy of yours who is already First Class or better, one of the troop leaders, or your father if he happens to be a camper.



Before taking off on these camping trips, think over carefully everything that is involved. The equipment has to be just right, the foodstuffs sufficient for the meals you intend to have. Everything has to be packed properly so that you will get it to camp with the least effort by whatever means you choose—in one case, at least, by backpacking your gear to your campsite.

When you arrive at the spot you have picked for your camp, take time to look it over carefully before you go to work. In that way you'll be certain to get camp arranged in the best way for efficiency and neatness. If you are using a tent, pitch it so that it stands right. If the weather is good, you may decide to sleep directly under the stars. In any case you'll need to make a comfortable bed.

Your fire should be safe, your meals well-cooked, your cleanup afterward—including putting out the fire—as good as can be expected of a camper on his way to First Class.

2b 🍀 *Before each camp submit a camp plan for approval (unless this is a troop camp) to your Scoutmaster or an adult assigned by him.*

Your Camp Plan. With so many details to think about, it will pay you to put your plans for your camping trips down on paper.

Jot down a list of the equipment you intend to take along. Write out your menus for supper, breakfast, and lunch, and develop a shopping list.

Figure out loosely a time schedule you want to follow: when to start from home, when to have your meals ready, when to get to bed and when to get up, when to get back home.

The kind of planning you do will help to show the kind of camper you are becoming.

Camper
pack and
frame



Yucca packs



GET READY — GET SET — GO!

2c  Before leaving on each of these (two) camping trips, present yourself for inspection suitably clothed for the locality, season, and weather and equipped for the occasion.

Clothing for Camp. Just as for hiking, you will find your Scout uniform the best clothing for camping. It is, as you know, designed specifically for rough activities in the outdoors. And then, of course, you want your whole gang to look like the Scout patrol it is. It can only do so if you are all smartly dressed in the Scout uniform.

For camping during the hot summer months you can keep cool in lightweight, short-sleeved shirt, shorts, and long stockings.

For cool-weather camping, you may find long-sleeved shirt, trousers, and socks more suitable.

For certain seasons of the year you'll require a sweater or jacket for cold days or evenings around the campfire. If you live where you can expect rain you will be prepared with a poncho or a raincoat and possibly rubbers.

When you are dressed, put in your uniform pockets your Scout knife, matches in a waterproof container, a small notebook with pencil, a couple of adhesive bandages, a handkerchief, an "emergency dime" for a dial telephone call, toilet paper, and your wallet.

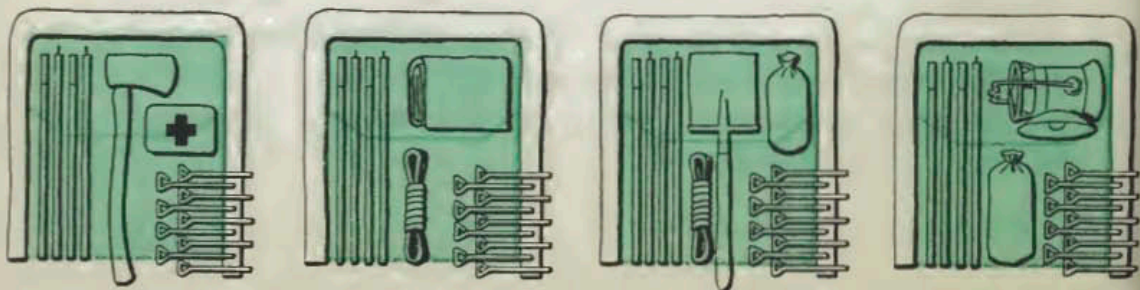

When the whole patrol takes off for camp, you distribute the patrol

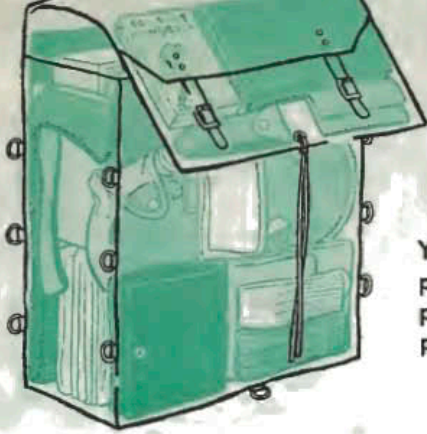

Yucca
pack
properly
packed



Packing Your Pack. Before starting to pack, check your personal gear against the list on page 242 and the patrol equipment you are to carry against the list you made up at the patrol meeting just before camp. The problem now is to get all of it packed.

If you are to carry a large sleeping bag or a tent, your best bet may be to roll it up in a sausage and attach it to the outside of your pack, horse-collar style, as shown above.

When it comes to things that go inside the pack, remember that a Scout pack is "a bag of bags." Items that belong together—eating gear, toilet gear, extra clothing—go into their own separate bags. This system makes it easier to pack your pack and easier to find everything. You can sew your own bags for this purpose from scraps of sheeting or other material. Even better are plastic bags with plastic zippers. Place the softest of these bags in the part of the pack that will rest against your back, with those items furthest down that you will use last after getting to camp. Keep rain clothing at the top of the pack where you can get at it easily if necessary.

2d 🍀 *On at least one of these (two) overnight camps, carry on your back, for a distance of not less than 1½ miles, a pack containing your personal equipment and your share of common camping equipment and food . . . After striking camp, repack your gear and carry it out at least 1½ miles.*

251

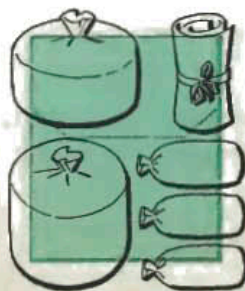
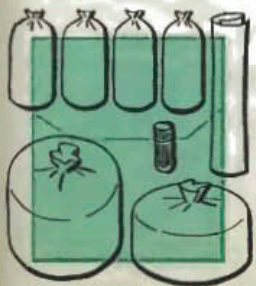

equipment among the members, each fellow carrying his fair share.



CAMP MAKING

Well, there you are with the whole gang on your favorite campsite. Now for putting up camp!

Not immediately though—not if yours is a smart patrol.

Before you do anything else, all of you put your packs down in a straight row—all turned the same way, close together. The *duffel line* is formed! It looks neat. It ought to—you're a top-notch patrol. Next, with your patrol leader in the lead, the whole gang strolls over the campsite and talks over how to set up camp most effectively. With everyone knowing exactly what needs to be done and where everything goes, you all go to work.

In a good patrol, the work of putting up camp is divided evenly among the members. Here, half of the gang may be a *tenting crew*—the fellows are responsible for pitching the tents, preparing beds, digging latrine and refuse pit, laying the evening's campfire. The other half is the *cooking crew*—the Scouts in it build the fire and arrange the kitchen, lay out cooking utensils and foodstuffs, get water and wood, cook and serve.

It is a joy to see a well-organized camping patrol at work. The tents seem to jump up out of the ground, the fire crackles under the pots—and before you know a word about it, the *foreman* of the tenting crew reports "All done!" and the head cook yells "Come and get it!" You won't have that kind of patrol the first few times you go camping—but if all of you make up your minds to become good campers you'll have it one of these days.



Using the Ax in Camp. If you are pitching camp on a spot that has been used for camping again and again you'll have little chance to wield your ax. But if you are lucky enough to have received permission to develop your own patrol campsite, you'll have plenty of use for an ax. That is when your Second Class axmanship ability comes into full play.

First thing, of course, is to make certain that your ax is sharp. If you sharpened it before leaving home, you're all right. Otherwise, get out your file and sharpening stone and use them.

To clear brush, bend the stem with one hand, thus straining the grain. Then cut with a slanting blow close to the ground. But remember this: Never let the ax edge end up in the dirt. Keep the ax under control to prevent the edge from getting nicked.

You can probably use some of the branches of the brush for making tent pegs. Select parts of the branches that are about an inch thick. Using a chopping block, cut them into even lengths—about 9 to 12 inches long. Now let's see what kind of axman you are: Holding one end of the piece against the chopping block, make four quick strokes with your hand ax, using the contact method, twisting the stick a quarter turn for each stroke. If you are good, the peg now has a perfect point. Lay the opposite end of the peg flat against the chopping block and, again using the contact method, cut a notch for the tent guy line about 2 inches from the butt end. Finally, trim the edge of the top of the peg (see illustration) to keep it from splitting when you drive it in.

If you have brought tent poles from home you're all set for tent pitching. If you haven't, you'll have to cut the poles from among the saplings that grow around your campsite—but by permission.

Three kinds of homemade
tent pegs

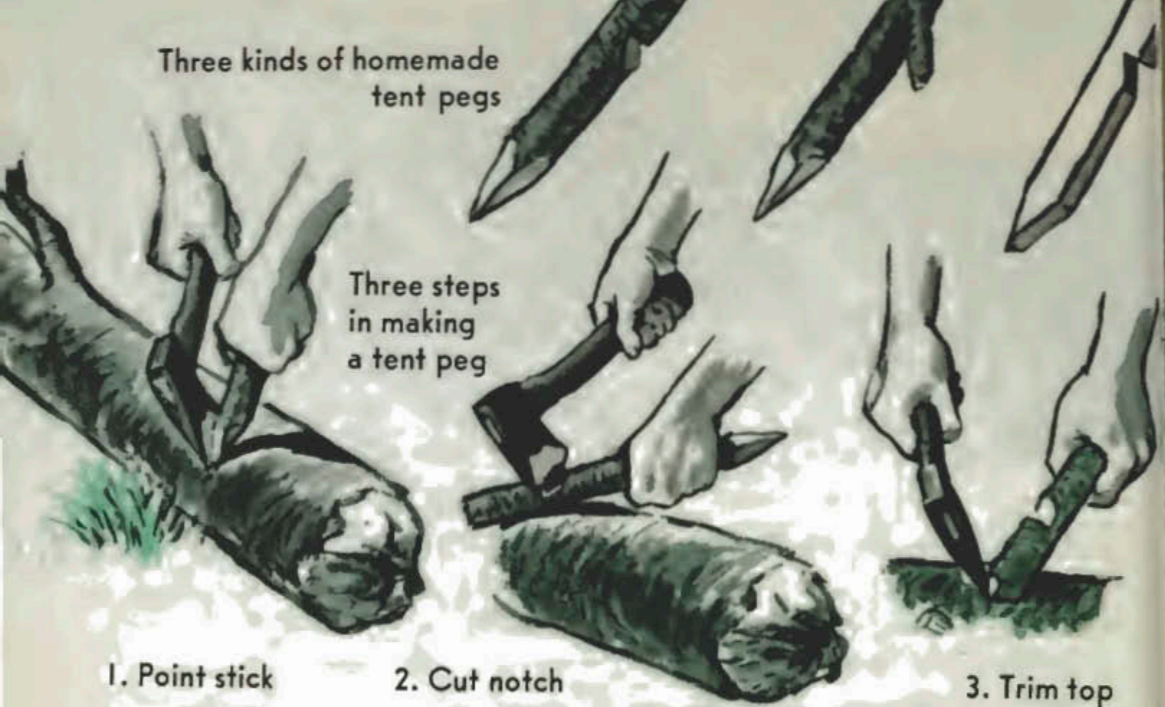

Three steps
in making
a tent peg

1. Point stick

2. Cut notch

3. Trim top

2e 🌿 *Pitch a tent correctly and use it for shelter during your encampment.*

The Tents Go Up! Take your tent to the place where you have decided to pitch it—preferably a slight knoll so you won't have to ditch in case of rain. Now, before pitching your tent, get down on hands and knees and go over every inch of the ground. Clear away hard bumps of grass. Pick up all stones—even the tiniest pebble will feel like a boulder if you try to sleep on it.

Open your tent and make certain that you have everything you need for pitching it—poles and pegs and guy lines. The poles should be exactly the right height—otherwise the tent won't stand right. Unless you have permission to cut poles on the campsite, you'll have brought the poles from home—sectional aluminum poles for a lightweight tent, wooden poles for a heavyweight. Your tent pegs may be lightweight metal tent pegs, or heavyweight hardwood, or cut on the spot from sticks 1 to 1½ inches thick, 9 to 12 inches long. For guy lines you may be using light nylon line or fiber glass cord or light rope.

Whether you're pitching an Explorer tent, a Camper, an Over-nighter, or a Baker, here are a few general rules you'll want to follow when you set up your tent:



Light - to - carry
metal tent pegs.

To pitch a tent, close tent door first. Then peg down the corners

First close the tent door by tying up the tapes. Next peg down the two front corners so that the tent front is lined up the way you want it. Then peg down the two rear corners in such a way that all floor corners are right angles.

Have a buddy raise a pole at one tent peak and hold it in upright position while you hammer down a peg at an appropriate spot and fasten the guy line to it with a taut-line hitch. Then have him raise the other pole (if tent has two poles) while you tie down the other guy line and stretch the tent ridge between the two poles.

Now go around the tent, peg the tent sides to the ground, drive in the remaining pegs and fasten the side lines (if any) to them with taut-line hitches. These hitches have great advantages for tent pitching in that they can be easily tightened to stretch the tent cloth, they hold under strain, and can be quickly loosened in case rain shrinks canvas and lines.

Take a good look at the tent to make certain that it stands right—the ridge without too much sag, the sides and walls smooth.

If you are pitching an Explorer tent with a single T pole, matters are simplified a bit—you have only one pole and one guy line to think about. If you prefer to put up an Explorer or a Wall tent with outside shear legs, you need one pole as long as the tent ridge



Drive down short tent peg until the notch is at the ground level.

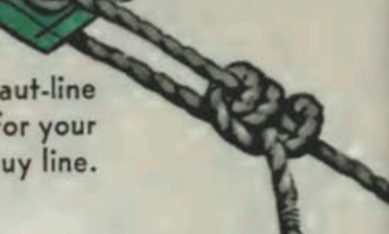

Use taut-line hitch for your tent guy line.



After staking down corner of tent, raise the tent pole



and two long poles for the shears. Tie the peaks of the tent to the ridgepole. Tie a short piece of rope in an open loop at the center of the ridgepole. Lash the two long poles into shear legs. Put the tip of one of the shears through the rope loop on the ridgepole and raise the tent (see illustration page 257).

Keeping Out the Rain. If you camp in a part of the country where you can expect rain, you'll have to make sure that the water won't flow through your tent and soak your bedding.

If you've pitched your tent on a small elevation or on ground that absorbs the water quickly you'll have little to worry about. Otherwise you may have to ditch your tent on the uphill side. The ditch need be only 4 inches deep and 4 inches wide. Cut inside of ditch flush with tent wall. Place the sod you dig up at the outside edge of the ditch, and replace it when camp is over.

Remember that ditching on sloping ground may create an erosion problem—so ditch only in an emergency and not at all if not permitted, as in State and National parks.

Making the Latrine. Now, before you do anything else, dig the latrine. Nothing elaborate—just a simple straddle trench. Place

Setting up tent
with shear legs.

tent
ditching



it at least 100 feet away from tents and kitchen and lower than your water supply. Dig it about 8 inches wide, a foot deep, and 3 feet long. Pile the dirt at one end and leave the shovel in the pile so that some of the dirt can be thrown in whenever the latrine is used. Hang toilet paper nearby, with an empty tin can around it to protect it from possible rain. If the latrine isn't naturally hidden by a thicket, put up some sort of screening around it.

Announce the location of the latrine to all campers as soon as it is made. Remember to fill it in completely before you leave.

2f 🍄 *Make a ground bed and sleep on it.*

And Now Your Bed. For the simplest type of camp bed, lie down in sleeping position, notice the spot on the ground where your hip is and scoop a shallow hollow there to fit your hip comfortably. Dig a smaller hole where your shoulder goes. For a one-night stand, all you have to do now is to spread out your waterproof ground cloth and arrange your bedding.

For more comfort, put a layer of straw, dry grass, dry leaves, or ferns under your ground cloth. Or turn your poncho into a mattress by filling it with straw and buttoning two edges around the fillings. A straw tick filled with straw or leaves makes an even

better mattress. Such a tick is a long bag about 28 inches wide, 6 feet long, which you can make from sheeting.

As far as the bedding is concerned, remember the old camp rule: Have at least as much under you as over you. In that way you are not only warm against the cold night air, but also against the coolness of the ground.

If you use only one blanket during a summer night, place one third of it on the bed and lie down on it. Bring the rest of the blanket over you so that the middle third is on top of you. Roll over slightly and tuck the last third under you. Lift your legs and bring the bottom of the blanket in under your feet. And you are all set.

With two blankets, place the left half of one on the bed and the right half of the other over it. Lie down and bring the other halves of the blankets over you, then tuck the bottoms under your feet. Even better, make a sleeping bag out of your blankets by folding them as above and keeping them in place with large safety pins—blanket pins.

For a fellow who'll want to do a lot of camping you'll find a regular sleeping bag preferable to blankets. The least expensive official Scout sleeping bag is filled with kapok; a better quality is filled with a synthetic fiber. All of them have a water-repellent cover but you will still need a tent for shelter from the rain and a ground cloth to protect you from the dampness of the earth.



How to fold two blankets for bed.

For comfort in simplest type of camp bed, scoop hip and shoulder holes.

CAMP HEALTH

2g 🍀 *On each of these (two) camping trips, follow proper sanitation practices and safety precautions and leave a clean camp.*

Care of Food and Drinking Water. You can divide camp food into three groups: (1) food like fresh milk and fresh meat that'll spoil unless kept at a low temperature, (2) fresh vegetables, fresh fruit, butter, and processed meats, such as bacon and smoked ham, that need to be kept cool, (3) canned and dried foods that keep at air temperature.

Place foods of the first two groups in some kind of refrigerator. If a brook runs by your camp, you can put them in a pail or large cooking pot and place this in the cool, running water. Otherwise, dig a hole in the ground, 3 feet square, 3 feet deep, and line it with stones. Cover it with a wooden cover so sturdy that no prowling skunk can push it aside. If the weather is very hot, arrange to get ice for your refrigerator. If ice is not available, better not think of taking fresh meat and fresh milk to camp in hot weather—use canned meat and powdered milk instead.

Keep water for cooking and drinking in a covered pot, protected against dust, insects, and animals. Or use a desert water bag and hang this where it is exposed to the breezes. The water seeps out through the canvas and keeps the contents cool by evaporation.



To keep animals from getting into food, you can try this method.

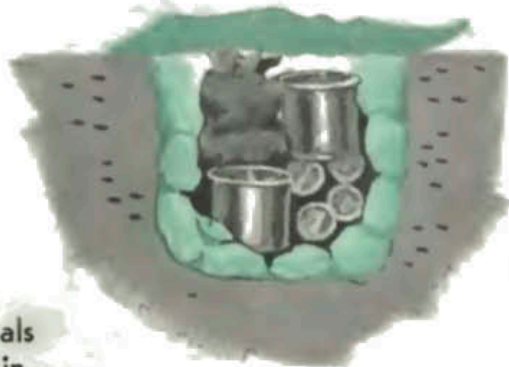

Hole lined with stones will help keep food cool.

Hang up desert water bag to expose it to the breeze.



Fire Protection. You already know how to a build safe fire, how to keep it safe, and how to put it out after using it (pages 184 and 185). In addition, it is advisable to have water handy, close to your tents. If you can't spare a pot for this purpose and have no pail, a couple of large tin cans full of water will do.

Waste Disposal. Dispose of garbage by burning to keep flies and animals from getting at it. You can use your cooking fire for this after you have finished cooking. Put several finger-thick sticks across the fireplace and dump the garbage on them. After the garbage has dried, add sticks to the fire to complete the burning.

Wash out empty tin cans and smash them flat. Wash out empty bottles and jars. Prove yourself a good camper by taking cans and jars home with you for disposal in your home garbage can. Bring a litter bag to take them home in.

Greasy dishwater thrown on the ground draws flies. Make a grease trap for it. Dig a pit the same size as your cooking pot. Cover it with sticks and top these with a layer of dry grass. When you pour the dirty water into the pit, the grass catches the grease. Burn the grass after each use and put on new grass.

Fill in grease pit before you leave for home.



For protection against fire, have a couple of water-filled pails on hand.

Dig pit for greasy water.

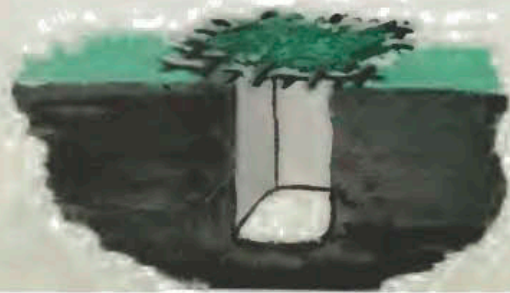

Make a straddle latrine. Pile up dirt at one end. Throw in dirt after each use.





COOK YOUR MEALS

At home, you don't have to think too much about what's cooking—your mother usually has the food ready when you are good and hungry. But in camp you're on your own. There it's a matter of having the right amount of the right foodstuffs and necessary cooking gear on hand, of knowing how to build a simple fireplace and make the right kind of fire for the meal you've planned, and of being able to cook—not just for yourself, but also for a buddy and, in patrol camp, for the whole gang.

2h  *On at least one of these (two) overnight camps, prepare from raw, dried, or dehydrated ingredients and cook over a fire in the out-of-doors a complete breakfast of fruit, hot cooked cereal, hot beverage, and bacon and eggs (or pancakes); and a complete dinner or supper of meat (or fish or poultry), vegetable, dessert, and bread (or biscuits or twist).*



For one-man camp cookery it is hard to beat the official Scout cook kit that comes in a close-fitting cloth cover. It consists of frying pan, stewpot with lid, cup, and plate. Eating kit has stainless-steel knife, fork, and spoon that clip together.



For training in patrol camping on overnights, you can make up a usable cooking kit from No. 10 tin cans.



For camping with the gang over a longer period, the Trail Chef Kit comes in handy. It has two frying pans, three stewpots, cocoa pot, four serving plates, and four cups.



What Food To Take. In planning tasty meals for camp it is important to include all the foodstuffs you need for good health and for growth. By picking your foods from each of the four groups below you're sure of getting everything that's required for making and keeping your body strong:

MEAT, POULTRY, FISH, EGGS—At least two helpings of meat (beef, veal, pork, lamb), poultry, or fish every day and at least three or four eggs each week.

MILK AND MILK PRODUCTS—At least one quart of milk daily, to drink plain or in flavored beverages or with cereals. The milk for drinking should be bottled, pasteurized milk. If this is not available, use powdered, dried milk instead. Also use milk in cooked foods.

VEGETABLES AND FRUITS—At least four servings daily:

Oranges, grapefruits, or tomatoes every day. Serve as is, as juice, or, in the case of tomatoes, stewed.

Dark-green or deep-yellow vegetables at least every other day, some cooked, some raw.

Potatoes, other vegetables, and fruits twice a day or as you like: potatoes, beets, cauliflower, onions, celery, string beans, navy beans, apples, pears, peaches, bananas, grapes, berries, melons, dried apricots, dates, figs, raisins, prunes.

BREAD AND OTHER FLOUR PRODUCTS—At least four helpings of whole-grain products or enriched bread daily.

In addition to these basic food groups, certain other things are necessary in cooking. We may group them together as:

ACCESSORIES—Use as desired. *Fats* (butter, margarine, salad dressing), *sweets* (sugar, candy, jam, jelly), and *flavorings* (salt, pepper, vinegar, mustard, cocoa).

For an overnight camp, most of your foodstuffs will be the raw kind—fresh eggs, fresh vegetables, fresh fruits. For a wilderness trip, where it is a matter of keeping down the weight, you will make use of dried and dehydrated foods—egg powder, instant potato, dry beans and peas, air-dried fruits, freeze-dried meats.

What Equipment To Take. When cooking for yourself, your best bet is the official Boy Scout cook kit. For buddy cooking, two of these kits will do the job. Or you may want to make up a

kit from your mother's kitchen. When it comes to cooking for the whole gang, your patrol will probably have a Trail Chef Kit that you can take along.

Use plastic bags and plastic containers for carrying the foodstuffs to camp. They make it easy to pack what you need.

For food preparation and for eating you'll need spoons, forks, and knives, and, of course, plates or bowls for serving.

Getting Ready To Cook. When cooking alone, you must, of course, do the whole job yourself. When cooking with a buddy, on the other hand, you have to decide between you who does what.

One of you will be the head cook—or *bull chef* as they say up in the North Woods—the other, the assistant.

The head cook lays out all the foodstuffs—on a small plastic sheet, if he is smart—and does the actual cooking and serving. The assistant acts as woodman, getting the firewood together; as fireman lighting the fire and keeping it going; as waterboy, going for water; and as all-round helper doing whatever chores need to be done. For the next meal, the two of you exchange jobs. In this way, both of you will get to be good camp cooks.

For cooking in patrol camp, your smartest trick is to make use of the system described in the *Handbook for Patrol Leaders*, of taking turns in performing the different jobs.

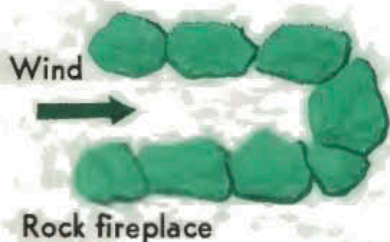

Your Fireplace

Some campers do all their cooking directly on a bed of hardwood coals. Others prefer to use flames and coals both and make one of the simple fireplaces shown on page 270. When cooking for the whole patrol, you may need one of the fireplaces shown below.

Rock Fireplace. If you are camping where there are plenty of rocks, you can build a simple rock fireplace. Choose rocks of an even size and as nearly flat on top and bottom as possible. After clearing the spot down to plain dirt, arrange the rocks in two rows, close enough together to support your cooking utensils.

Trench Fireplace. In an open spot, a trench fireplace is good. Dig it just wide enough to fit your pots, about a foot deep, 2 to 3 feet long. Widen the windward end to catch the wind for good draft. The trench fireplace goes light on fuel and is safer than an above-the-ground fireplace on a windy day.

Hunter's Fireplace. In the woods, you may be able to make a hunter's or trapper's fireplace. For this, you need two logs of hardwood, 2 to 3 feet long, 6 to 9 inches thick. Roll them up on either side of your fire, about 6 inches apart. Since this kind of fireplace is made of wood, the fire will gradually eat up the logs from the inside—you'll have to replace the logs from time to time.

Wind



Hunter's fireplace





Breakfast in Camp

For breakfast in camp you want a substantial meal with fruit, cereal, a main dish—such as eggs, bacon or ham, or pancakes—and a beverage. On a cool day, have a hot cereal and hot cocoa. On a hot morning, use cold cereal and milk.

2h ☞ cook . . . a complete breakfast of fruit, hot cooked cereal, hot beverage, and bacon and eggs (or pancakes)

Fruits. In preparing stewed fruits, use for each serving four to eight prunes, or four to eight dried apricots, or three to four dried peach halves, or $\frac{1}{4}$ cup dried apples, and sugar to taste. Cover the fruit with water, bring to a boil, then simmer—that is, keep just below the boiling point—for 15 to 30 minutes. When almost done, add sugar—2 to 4 teaspoons. You will cut down your cooking time if you soak the dried fruits overnight.

Fresh fruits come in handy for breakfast. You can get oranges, grapefruit, bananas, and apples year round. In season you can get melons and berries. Keep your eyes open for wild berries when in camp. And then, of course, there are canned fruits and juices.

Cereal. In making hot oatmeal, figure $\frac{1}{2}$ cup instant oatmeal for each serving. Bring $\frac{3}{4}$ cup of water to a boil. Put the oats in a bowl. Pour the boiling water into the oats and stir until mixed thoroughly. Sprinkle with salt and stir.

For making hot farina, use $\frac{1}{4}$ cup farina or similar cereal for each serving. Pour cereal into 1 cup boiling water. Add a pinch of salt. Boil gently for 5 minutes, stirring frequently.

Bacon and Eggs. Each camper will probably want three to four slices of bacon and two eggs. Put the bacon into a cold pan and cook over a slow fire, turning the slices when half done. Do not overcook—the bacon will crisp as it cools. As the fat collects, pour it off into a container and save it—it is excellent for frying. Now break your eggs into the pan. Fry over slow heat until the white becomes actually white and firm.

Pancakes. Pancakes or griddle cakes or hot cakes are made in a large frypan or on a griddle. They are about 4 to 5 inches in diameter and are flipped with a knife or a pancake turner. For each camper you need $\frac{1}{2}$ cup of prepared pancake flour. Make the batter according to the instructions on the box. (If you have no prepared flour, use a mixture of $\frac{1}{2}$ cup of ordinary flour, $\frac{1}{2}$ teaspoon baking powder, 1 pinch of salt, $\frac{1}{2}$ teaspoon sugar.) Heat your pan and grease it with a little butter or margarine or bacon fat. Pour in batter for enough cakes to fill the bottom of the pan. Fry over a slow fire. Soon bubbles form on the top. When the bubbles burst in the center of the cakes and the edges begin to brown, turn the pancakes and fry the other side. Serve with butter and syrup or jam or sugar.

Hot Beverage. Depending upon whether you want one or two cups of hot cocoa, bring 1 or 2 cups of water to a boil. Add one individual package of cocoa per cup and stir. For a richer cocoa, add 1 or 2 tablespoons powdered milk.



The patrol camp gives you a wonderful chance to learn camp cookery. Every fellow there aims to become the master cook of the patrol.



Lunch in Camp

Lunch comes during the hottest hours of the day—so you probably won't want to do much cooking. Nevertheless, you may feel almost starved—so what to do? A couple of sandwiches, a cold drink, and a few cookies will usually satisfy any hungry boy at high noon. On the other hand, if you want to have your main meal in the middle of the day there's nothing to hinder you. Then use the recipes starting on the next page.

Sandwiches. For one serving: four to six slices of enriched white or dark bread, fillings. For fillings, use hard-boiled eggs, cold cuts, cheese, sardines, tuna or salmon, sliced tomatoes, peanut butter, jelly, jam, or whatever else you wish. A couple of lettuce leaves and a dab of salad dressing add to taste and looks.

Hot Dishes. If you are willing to take the time or feel in a picnic mood, you may want to light a fire and prepare a simple, hot dish for lunch. It is an easy matter to fry up a hamburger or to grill a frankfurter.

Or make a toasted cheese sandwich by simply frying a regular cheese sandwich on both sides in a little butter.

Or try one of the aluminum foil tricks on pages 272-273.

If the weather is cold or rainy you will certainly want something hot. Nothing, then, quite like a bowl of piping-hot soup.

Soup. For one serving: half a can of condensed soup or one-third package of powdered soup. Dilute condensed soup with an equal amount of water; heat. Follow instructions on package for powdered soup.



Dinner or Supper in Camp

The evening meal is generally the main meal in camp. It will consist of a meat, poultry, or fish dish with a choice of vegetables, bread or biscuits, dessert, and beverage.

2h * . . . cook . . . a complete dinner or supper of meat (or fish or poultry), vegetable, dessert, and bread (or biscuits or twist).

Cooking With Pots and Pans. When cooking with pot or pan, you must have a way of placing your utensil over the fire.

You can make a simple fireplace for pot or pan by pushing three stones of equal size close to the fire in the form of a triangle to set the utensil on, or by laying two thick pieces of wood on opposite sides of the fire, parallel to each other.

You can also hang a pot by its handle or bail from a notch in a *dingle stick*—a stick pushed into the ground so that it leans in over the fire, or held in this position by rocks or forked sticks.

Before putting a pot or a pan over the fire, rub the outside with a piece of soap or with wet clay. That trick will make the cleanup much easier.

What did you bring to eat? Meat and vegetables? Very well—here are some ways to prepare them:

Ground Steak With Home-Fried Potatoes. You will need $\frac{1}{3}$ pound of chopped round steak or hamburger made into a $\frac{3}{4}$ -inch-thick cake; one large potato, peeled and cut into $\frac{1}{4}$ -inch slices; 1 level tablespoon shortening; a pinch of salt. Melt shortening in pan. Put in the potato slices and fry until slightly

Three stones make a satisfactory support.



You can use two thick sticks instead.

Dingle stick is woodsman's way of hanging pot.

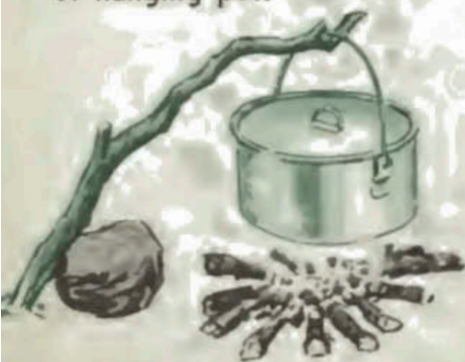

browned. Cover the pan with a lid and continue frying by steam, until potatoes are done. Push potatoes to one side, put chopped meat cake in the pan, and fry on both sides until it is done. Season.

Pepper Steak. Get together $\frac{1}{3}$ pound of flank steak, cut against the grain in $\frac{1}{4}$ -inch slices; one medium onion, peeled and cut in $\frac{1}{4}$ -inch slices; one medium green pepper, quartered, the seeds removed, then cut into $\frac{1}{2}$ -inch-wide strips; 1 level tablespoon shortening; a pinch of salt. Melt shortening in pan and fry the onions until brown. Add meat slices and brown them. Throw in the green pepper strips. Cover pan with lid. Continue steam frying over low fire until meat is tender. Season with salt.

Pork Chops With Fried Tomatoes. For this you need $\frac{1}{2}$ pound of pork or lamb chops; two medium tomatoes, cut in $\frac{1}{2}$ -inch slices; a pinch of salt. Place the chops in the hot pan and fry over low fire until brown and well done, about 15 minutes on each side. When chops are cooked, add tomato slices and fry in grease from chops. Season with salt.

Fried Fish With Boiled Potatoes. You will want $\frac{1}{4}$ to $\frac{1}{2}$ pound fish; one large potato; 1 tablespoon butter; pinch of salt. Peel and quarter potato. Boil until done in enough water to cover—20 to 25 minutes. Clean fish, wipe dry. Fry in butter until golden-brown on one side. Turn, fry other side. Season with salt.

Breadstuffs. BISCUITS—Use $\frac{1}{2}$ cup or more of ready-mixed biscuit flour. Follow directions on the package for mixing the dough. Divide the dough into three or four parts and pat into biscuits about $\frac{1}{2}$ inch thick. Place the biscuits on the greased pan of a reflector oven and bake in front of a steady fire for about 15 minutes. Test by pushing a straw into one of the biscuits—if the straw comes out clean, the biscuits are done.

Twist—Figure on using $\frac{1}{2}$ cup of ready-mixed biscuit flour. Make the dough right in your flour bag. Make a hole in the center of the flour and pour in a small amount of water. Stir until the dough has formed. Shape the dough into a long sausage and twist this around a stick as thick as your thumb. Push the stick in the ground close to the fire. Turn occasionally and bake until done.

Desserts. PUDDING—One-third of an instant pudding powder makes a good serving. Follow recipe on the box.

MAGIC LEMON PUDDING—Mix one quarter of a can of sweetened condensed milk with lemon juice. You'll be surprised at what happens. Add a handful of crushed graham or chocolate crackers or ginger-snaps.

SHORTCAKE—For one good serving, use $\frac{1}{2}$ cup of ready-mixed biscuit flour, 2 teaspoons of sugar. Prepare the dough according to the directions on the package, but with the sugar added. Make into two biscuits and bake them in a reflector oven. Serve with crushed, sweetened berries.

It is easy to make bread in camp in the form of twist.



Reflector oven can be used to roast meat as well as to bake breadstuffs.



You can bake in a cook kit. Place in firebed and put live coals on top.





Wrap up
food neatly.

Cook over
coals.

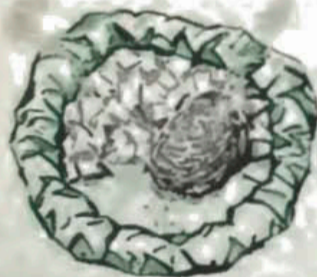
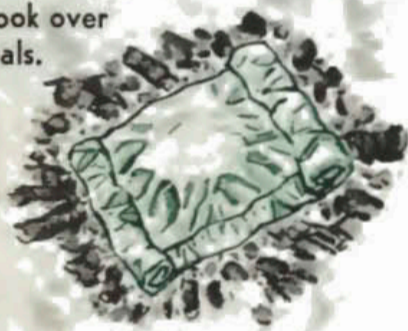

Serve on foil plate.

Cooking With Aluminum Foil. "Perfect camp meal—no pots or pans to carry—no utensils to clean afterward." How does that sound to you? Great, but impossible? Not at all—if you go in for aluminum foil cookery. You simply wrap your foodstuff in double thicknesses of foil in such a way that the steam cannot escape and place the package in hot coals. When cooked, the foil is your plate.

Aluminum foil can be bought in most grocery and hardware stores. It comes in rolls. But don't bring the whole roll for an overnight camp—just cut off what you need, fold it up loosely, and bring it along. Or fix your foil package at home, ready for cooking in camp.

The fire is the important thing in aluminum foil cookery. You need coals—so let the fire burn down into a solid bed of them. Push away some of the coals in the center, place your foil package, push the coals back over it, and leave it for the proper length of time.

Hamburger à la Foil. For one camper, $\frac{1}{4}$ pound of hamburger made into a $\frac{3}{4}$ -inch-thick cake; one large potato, peeled and cut into strips as for french fries; one medium carrot, scraped and cut into sticks; a pinch of salt. Place the ingredients side by side on a double layer of foil. Close up the foil package and place it in the coals. Cook for 15 minutes.

Foil Stew. Cut $\frac{1}{4}$ pound lamb shoulder into 1-inch cubes; peel one medium potato and cut it into 1-inch cubes; peel

and quarter one medium onion; scrape one carrot and cut it into $\frac{1}{2}$ -inch slices. Wrap the ingredients with a little salt in double layer of aluminum foil. Place in coals and cook for 20 minutes.

Foil-Broiled Steak With Lyonnaise

Potatoes. For a swell meal: $\frac{1}{2}$ pound steak; one large potato, peeled and cut in $\frac{1}{4}$ -inch slices; one medium onion, peeled and cut in $\frac{1}{4}$ -inch slices; 1 level tablespoon butter; a pinch of salt. Wrap potato and onion slices in foil, with the butter and salt. Cook in coals for 15 minutes. The steak is not wrapped, but placed on a piece of aluminum foil directly on top of hot coals. Cook 1-inch-thick steak 6 minutes on each side for rare, 8 for medium, and 10 if you like your steak well done.



Use aluminum foil frying pan.



Fried Chicken and Roast Corn. Each camper gets one chicken leg (drumstick and thigh, cut apart); two ears of corn, with husk and silk removed; 1 level tablespoon butter; a pinch of salt. Smear chicken pieces with butter and wrap in separate packages. Spread remaining butter on the corn, sprinkle with salt, and wrap ears in separate packages. Cook chicken in coals 20 minutes, corn 10.



Baked Fruit for Dessert. Wrap apple or banana in aluminum foil. Place wrapped fruit in the hot coals. Bake apple about 30 minutes, banana 10.

Try baking a whole fresh pineapple in aluminum foil some day. Yummy!!

Bake apple for dessert.

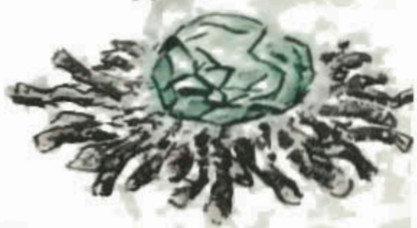



Use hot water for dishwashing. Sterilize tableware in hot water.

2i 🌱 *Clean up (after cooking), properly dispose of garbage and trash, put out your fire. . . .*

Clean Up After Cooking. Get this job out of the way as soon as you have eaten.

The smart thing is to put a pot of water over the fire the minute the food is cooked—it will be hot by the time you are ready to wash dishes, pots, and pans. Wash the dishes in part of the hot water with soap or detergent, use the rest of the water for rinsing and scalding.

Get rid of the garbage. Burn whatever will burn at one end of the fire. Wash out cans and flatten them. Wash out empty jars. Dispose of washed-out cans and jars as described on page 260.

Put out the fire. Straighten up the camp kitchen so that it is in good shape for the next meal.

2i 🌱 *and leave a clean camp.*

Clean Up After Camping. The really good camper leaves his campsite in a better condition than he found it. To do that, check these points especially:

Did I scatter the leaves or grass that I used for my camp bed?

Did I fill in all ditches and holes and replace what sod I dug up?

Did I burn all garbage?

Did I make positive that my fire was dead out?

Leave behind you only the two things that a Scout camper always leaves on breaking camp:

—A CAMPSITE IN BETTER SHAPE THAN HE FOUND IT

—HIS THANKS TO THOSE WHO MADE THE CAMP POSSIBLE

IMPROVING YOUR CAMP

For an overnight camp, you need little in the line of camp improvements. But if you are staying for a week or more you'll want to make a few pieces of camp equipment. Camp furniture and gadgets are fun to make—they show your inventiveness and add the comforts of home. But don't go overboard and spend half of your time in camp making gadgets—make just what you feel you need and can make good use of.

Most of the improvised camp equipment you'll want to make will call for tying sticks or poles together with lashings, using binder twine, cord, or rope, depending on the thickness of the wood. For tying parallel poles together, you use a shear lashing. For crossed poles, you use a square lashing. Where crossed poles do not touch, you spring them together with a diagonal lashing.

3 🌿 *Lash poles together with shear, square, and diagonal lashings.*

Shear Lashing. Place two poles alongside each other. Start with a clove hitch around one of the poles, at the appropriate distance from the top. Then lash both poles together with seven or eight turns of rope laid loosely beside each other. Make two frapping turns between the poles. Finish with a clove hitch around the pole opposite the one on which you started. Open out the poles.

A shear lashing laid around three poles will give you a tripod.

Two shear lashings may be used to lash two poles together—as when you want to raise your patrol flag. For these lashings, you start and end with a clove hitch around both poles and do not use frapping turns.

Flagpole



Shear lashing



Shear lashing for tripod



Shears for tent



Washstand

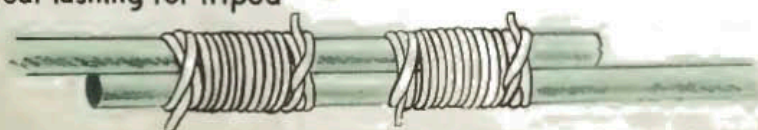

Shear lashings for extending poles



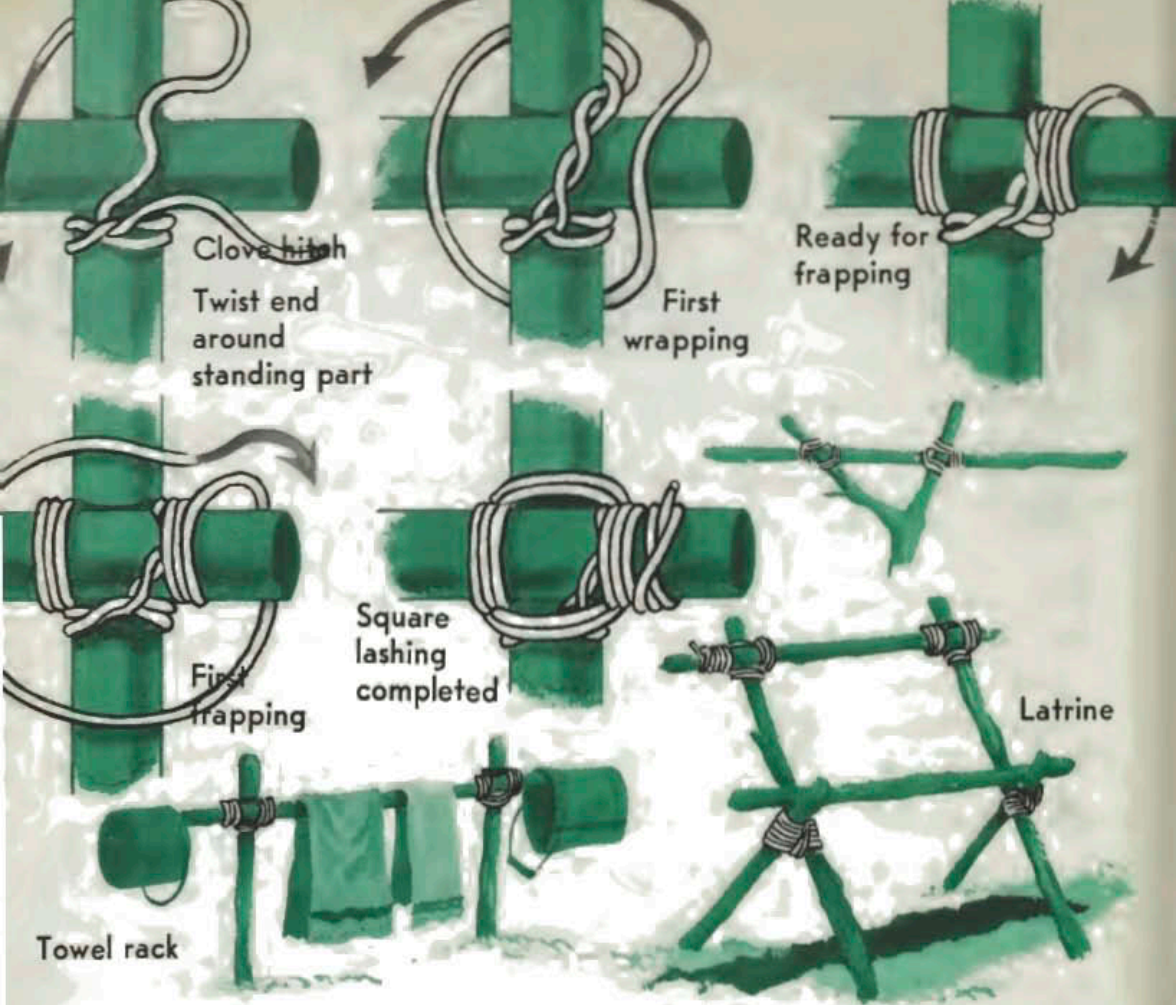

Square Lashing. Place two poles crosswise on each other. Tie a clove hitch around the upright pole, immediately under the place where the horizontal crosspiece is to be. Twist the short end of the rope around the standing part for neatness, then lay three turns around upright and horizontal both, keeping the rope taut all the time. In laying the turns, the rope goes on the outside of the previous turn around the crosspiece, on the inside of the previous turn around the upright. Then make two frapping turns between the poles to tighten the turns already laid. Strain the frapping turns as much as possible and finish off with a clove hitch around the end of the crosspiece. Remember: Start with clove. Wrap it thrice. Frap it twice. End with clove.

Diagonal Lashing. When it is necessary to spring two poles together to make them touch, you use a diagonal lashing. This



Timber hitch loose

Timber hitch



Timber hitch taut



First wrapping



Cross wrappings



Frappings



Diagonal lashing completed



Signal tower

lashing is started with a timber hitch around the two poles at the point of crossing.

To make this timber hitch, you pass the end of the rope under and around the poles, carry the end under and over its own standing part, and twist the end around its own part a few times before pulling it taut. Now take three turns around both poles, following the lay of the timber hitch. Be sure that the turns lie next to each other, not on top of each other. Take three more turns, this time crosswise over the previous turns. Strain the turns. Make a couple of frapping turns between the two.

When you know your lashings, you can produce anything from a clothes hanger and a washstand to a raised fireplace and a dining table. You can pitch your tent with outside poles, raise your patrol flag high above your camp, and even build a signal tower or a monkey bridge if you're ambitious.



MAPPING

Sometime on an expedition out of camp or on a hike alone or with your patrol, you may come upon a spot that seems to you perfect for a troop overnight sometime or as a special troop hike destination. But how are you getting the other patrols excited about going? One way is to present your discovery to them in the form of a well-executed map of the area.

With all the hiking you have done already with compass and map, it will be comparatively easy for you to produce a sketch map of the area you have found.

There was a time when you needed three instruments for making a map: compass, protractor, and ruler. Those days are gone forever. Nowadays, all you need is an official Pathfinder compass or, even better, the official Explorer III compass with its liquid-filled compass housing.

4 🌿 *Using compass and your step measurements, make a sketch map of an area approved in advance by your leader. Include map symbols indicating location of at least 10 landmarks, a north arrow, and scale in feet.*

The outline of the measured legs of a route is called a traverse.

278

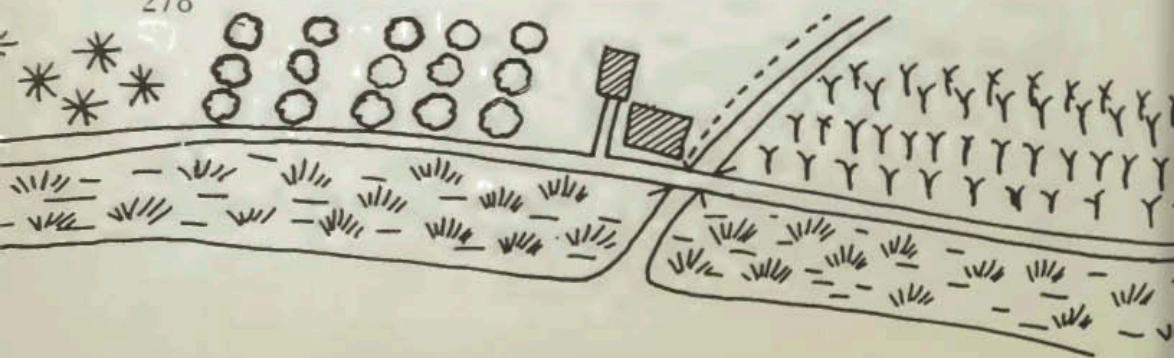



Getting Ready for Mapping. For drawing the map you need a pencil and a sheet of fairly heavy paper or thin drawing board and a firm backing, such as a piece of plywood or thick cardboard. Even simpler is the use of a drawing pad, 9 by 12 inches.

Prepare your paper by providing it with a number of parallel pencil lines, 2 inches apart. These are your magnetic north-south lines—similar to the magnetic north-south lines you made up over the topographic map you used for Second Class hiking. You will use them for transferring directions from compass to map.

Three Features of a Map. To make a map, you have to give attention to these three factors:

DIRECTIONS—These you secure with the help of your compass. They are simply the bearings you learned to take for Second Class. Your finished sketch map must contain a magnetic north half-arrow to show how the map is to be oriented.

DISTANCES—These you measure in steps. A good scale for a sketch map is 10 steps in the field equal to $\frac{1}{4}$ inch on the map—40 steps equal to 1 inch, 100 steps equal to $2\frac{1}{2}$ inches. This will give you a map in a scale of approximately 1 inch to 100 feet—or, in map language: 1:1200. When your sketch map is completed,

If traverse does not end at start (as here) it is an open traverse.

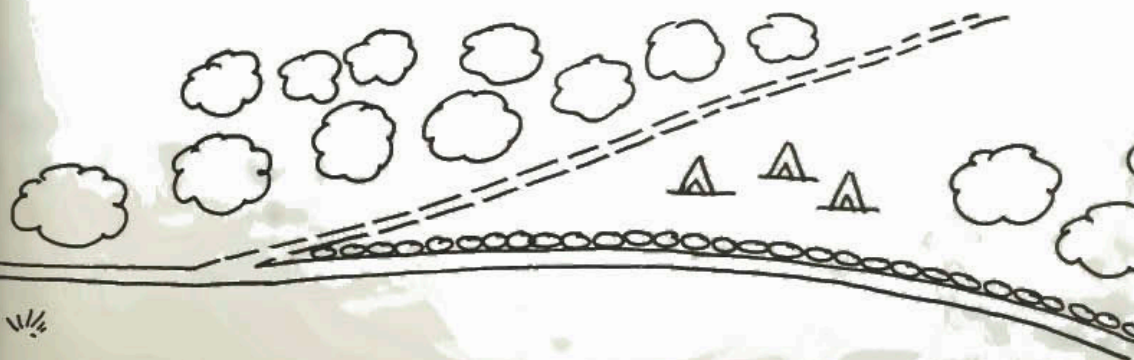

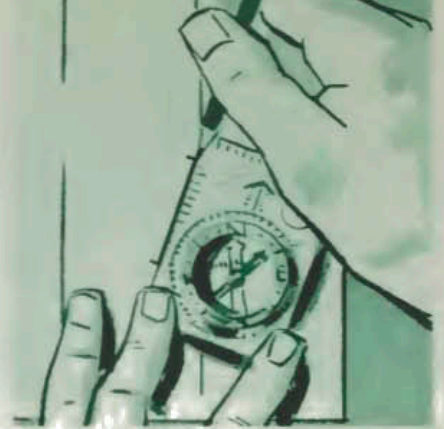

DIRECTION is found by taking a compass bearing to the next point in the field and then transferring it to your map sketching paper.

but not before, you include on the map a scale in feet to fit the scale in steps.

DETAILS—These are shown by map symbols. Because your sketch map is to a much larger scale than ordinary topographic maps, the symbols will be much larger. In addition to the usual symbols, you may want to develop your own to indicate tents, campfire circle, and so on.

Covering the Area. The area you plan to map may be an elongated one, lying along a road or a stream, or it may be a rather compact one. In any case, you need to decide on a route to follow through the area from which your compass bearings and your measurements can be taken. Such a route is called a *traverse*. It can be straight, in which case it is called an *open traverse*. Or it can start and end at the same point; a *closed traverse*. To show that you know your mapmaking, the traverse should be about $\frac{1}{4}$ mile in a landscape with many twists and turnings, longer if the area is flat, with few features.

Making the Map. After you have decided on your area, pick a suitable point on the paper for your starting point. Choose it so that you can be sure to get the whole map on the paper. If, for

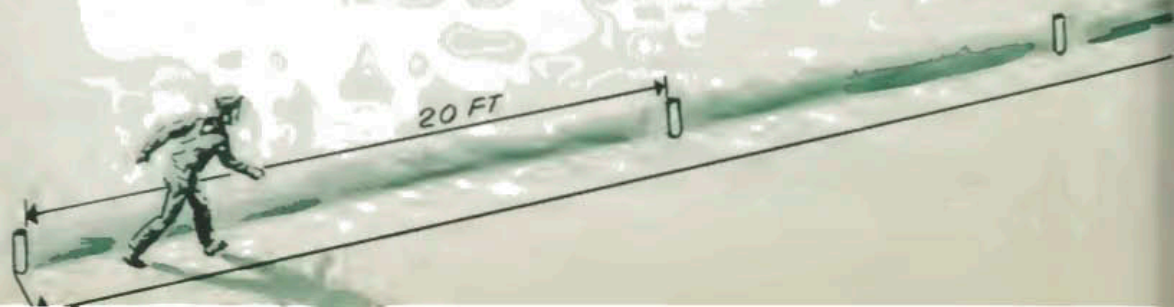

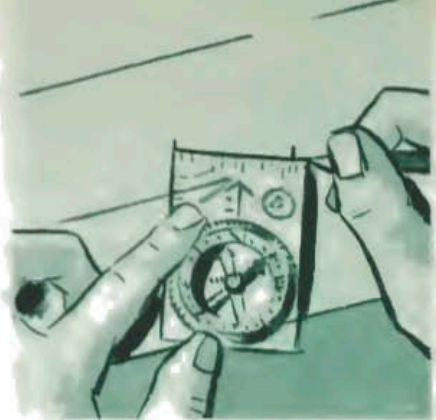

DISTANCES are measured in steps. Count steps along leg of traverse, then transfer the distance to map by using inch-ruler or compass.

instance, the area you plan to map lies to the northeast, you'll mark the starting point close to the southwest corner of your map.

The first leg of your traverse lies in front of you—from the place where you stand to the place where the road makes a decided turn.

To get the *direction*, you take a bearing with your Pathfinder compass in the usual fashion: you hold the compass level, with the direction-of-travel arrow pointing straight ahead, and twist the compass housing until the north arrow on the bottom of it lies directly under the north part of the needle. The compass is now set for the first direction. You transfer it to the map by placing the compass on the paper with the edge of the baseplate touching the

To find the length of your step, use a string 20 feet long to lay out a course 200 feet long. Walk the distance several times while you count number of your steps.



Divide 200 feet by number of steps taken. If you covered course in 100 steps, your step is 2 feet; if in 80 steps, your step is $2\frac{1}{2}$ feet. When you expect to do a lot of mapping, practice to make your step fit one of these lengths.

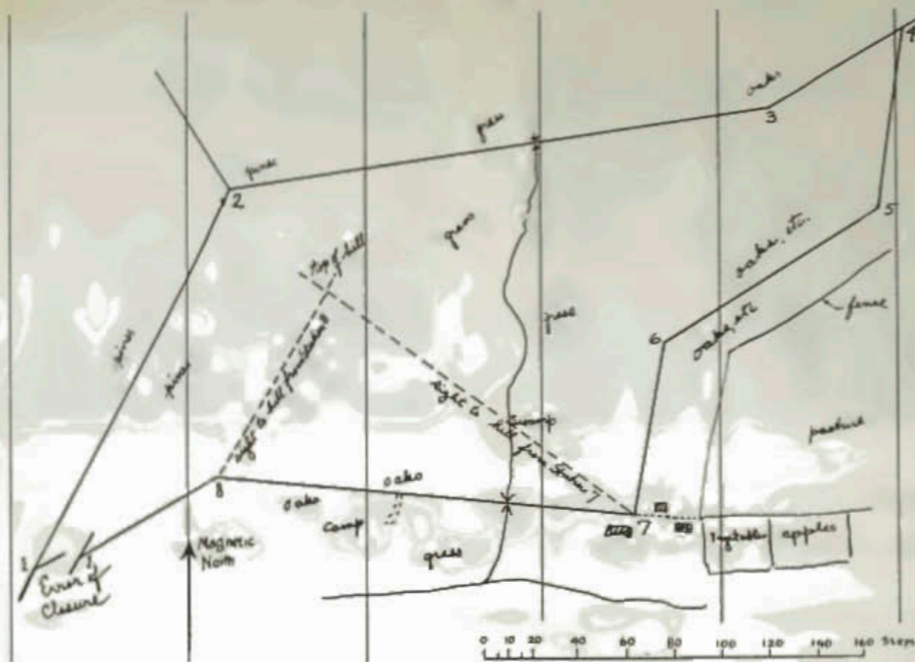

A closed traverse ends where it began. If directions and distances were carefully taken, end and beginning should be close together.

point where you stand, shifting the whole compass so that the north-south lines of the compass housing are parallel to the north-south lines on the map, then draw a line along the edge of the baseplate.

To get the *distance*, you step it off by walking to the point where the road turns. You mark off this distance on the direction line you have just drawn, remembering that $\frac{1}{4}$ inch equals 10 steps.

Then take the direction to the next point along the traverse. Transfer it to the map as before and measure out the distance on it. And so on until you have completed the traverse.

As you go along, indicate the features you pass by noting them down—a bridge you cross at a certain point, a fence along the road, a house to one side, a barn to the other. If an object lies at some distance to the side of the traverse, judge the distance to it in steps and note it down. If you want to have the distance completely correct, you can step it off, or you can locate it by *triangulation*. For this you take the compass bearing to the object from one station along the traverse and transfer it to the map, and another bearing from the next station which you also transfer to the map. The object is located where the two lines cross.

When you have covered your area, your traverse (if a closed

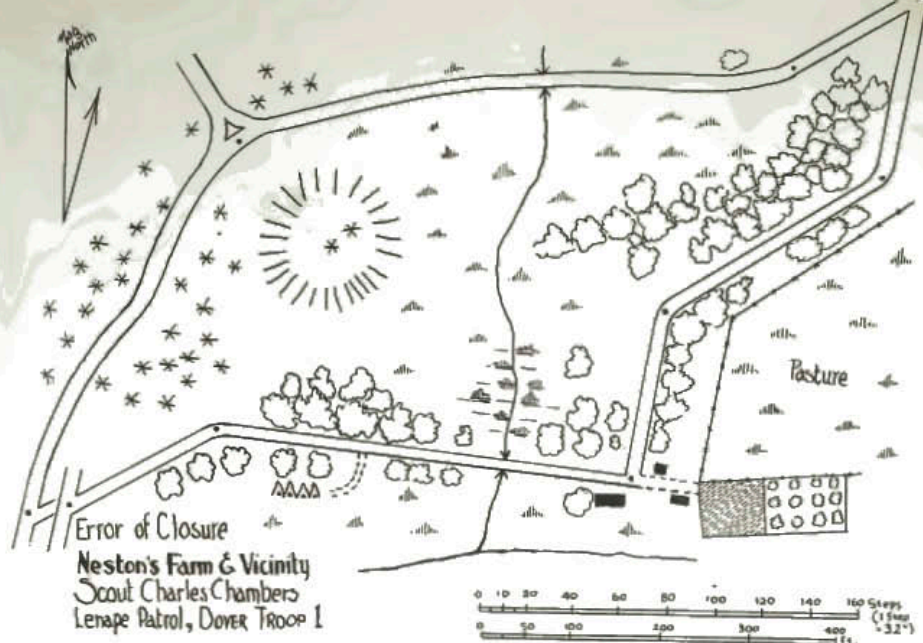

DETAILS of sketch map are enlargements of topographic map symbols. Finish the map by drawing it up neatly, using at least 10 symbols.

traverse) will look somewhat like the sketch on the opposite page. Note that start and finish do not come together but are marked *error of closure*. Even the best map maker will finish a closed traverse this way. This is okay unless the error is too great. In that case you will have to go back over your traverse to check your directions and distances.

Finish the map, preferably in ink, by drawing in the *details*—the map symbols that show the features of the area.

Remember that your map is not complete until you have provided it with magnetic north half-arrow, scales in steps and in feet, name of area covered, mapmaker's name, and date it was made.

SYMBOLS FOR SKETCH MAPS

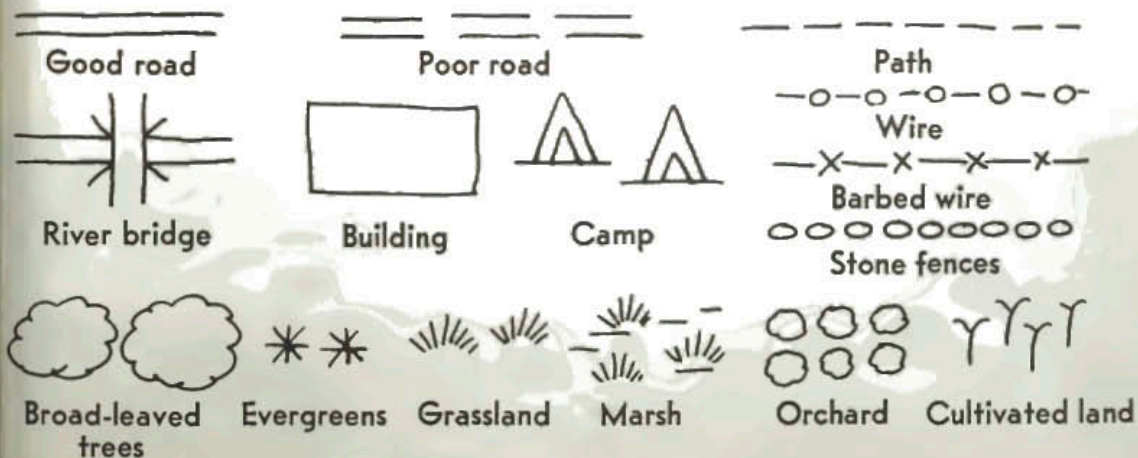

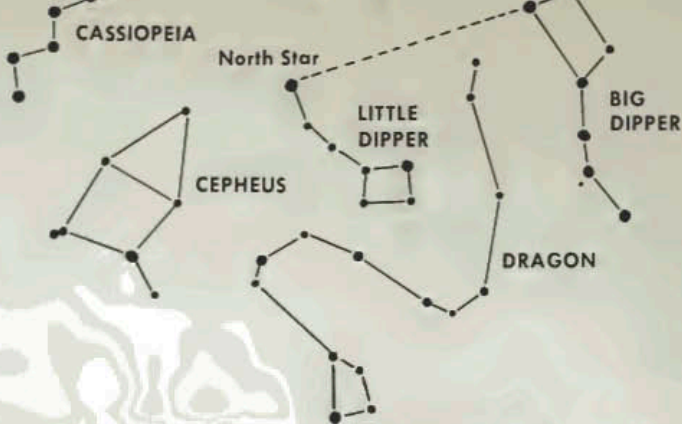

THE STARS IN THE SKY

Some evening in camp, get out and get under the stars. On a bright night, the sky above is crowded with thousands of brilliant points of light. Each of them—with the exception of a few wandering bodies called *planets*—is a sun as large or larger than the one that shines over your camp during the day. It looks smaller because of the immense distances in space.

For thousands of years, people have grouped the stars into figures called constellations—from the Latin *con*, together, and *stella*, star. The old Greeks and Romans thought they could see in the stars the figures of heroes, kings, and queens and named them accordingly. Today, the constellations help us find our way by ship across the ocean, by plane through the air, by rocket through space. One of them will help you find north on a night hike.

As you compare the star maps on these pages with the night sky, you may see somewhere on the imaginary line marked “Zodiac” a bright spot not indicated on the map. You will have located a planet rather than a star. The Zodiac is a sort of “racetrack” along which run not only the planets but also the Sun and the Moon.

5 🍀 Point out in the sky the North Star and at least five constellations.





Finding the North Star. To find the North Star, locate the Big Dipper—the four stars of the bowl, the three of the handle.

Now use the two stars of the bowl farthest from the handle—the *pointers*—to guide you to the North Star at the end of the handle of the Little Dipper. The distance is about five times the distance between the two stars. North lies at the horizon directly under the North Star. Other methods to locate the North Star are shown on page 286 using the Dragon, and the Swan. You can also use your compass to find the North Star; see page 131 for the compass reading of true north in your area.

Constellations in the Northern Sky. In addition to the Big Dipper and the Little Dipper there are other constellations in the northern sky you should know. If you continue from the pointers of the Big Dipper through the North Star in a curved line across the sky you will strike a constellation of five stars which, depending on the time of the year, looks like a crooked W or M. This is Cassiopeia, the queen. The lady's husband, King Cepheus, is close by. He looks more like a square house with a triangular roof than a king. Between the two Dippers crouches the Dragon, a long line of weak stars. The constellations around the North Star are visible throughout the year.

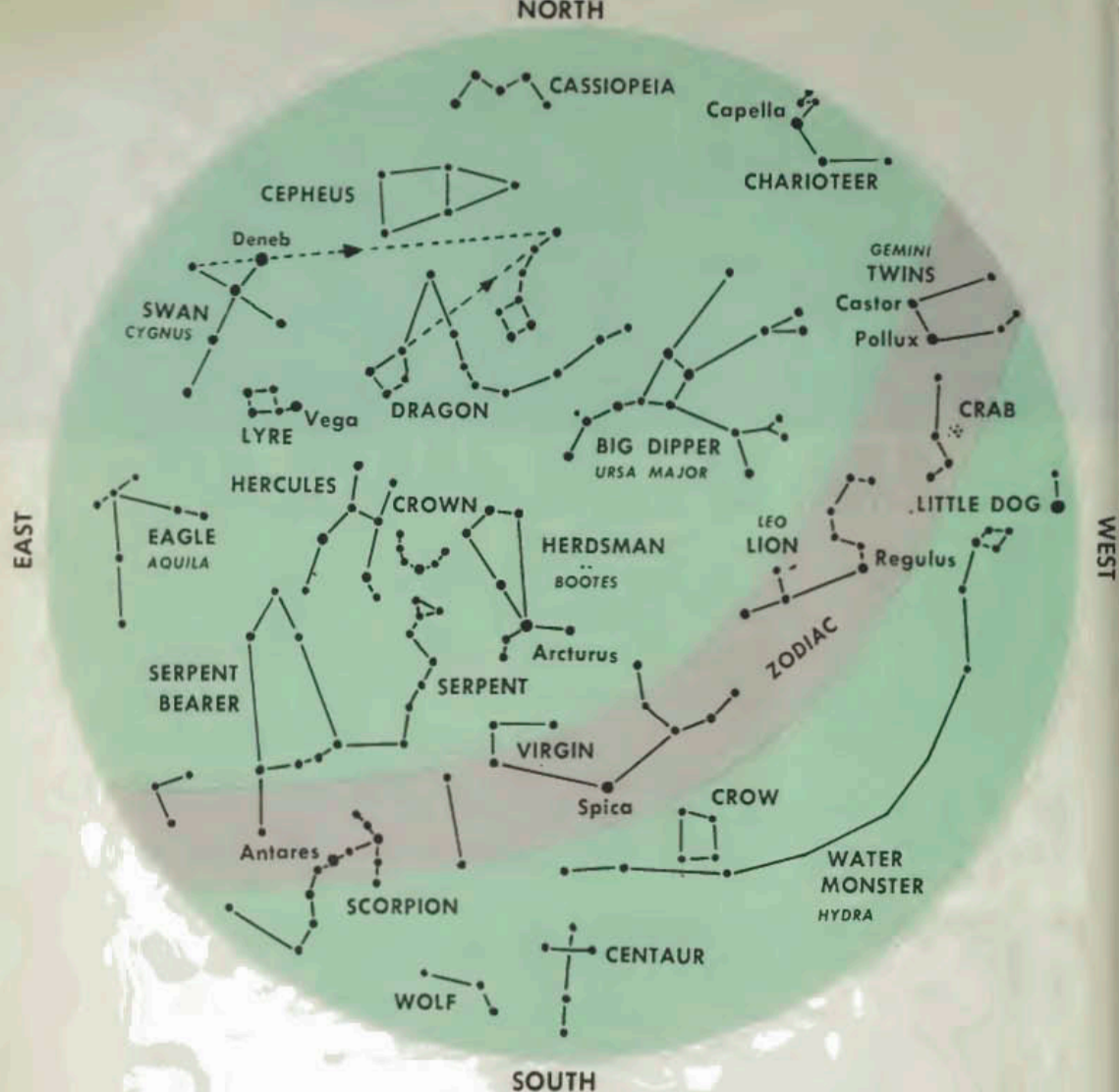

Summer Stars. By following the pointers of the Big Dipper away from the North Star you'll find the Lion, with the star Regulus. Between Regulus and Capella are the (Gemini) Twins—Castor and Pollux. Between Cassiopeia and Vega, five stars form a wide cross: the Swan or Northern Cross. By following the curved handle of the Big Dipper you come upon Arcturus, the brightest star in the Herdsman. Nearby is a half circle of stars called the Crown. Move on to Hercules, then notice how the Dragon's head and two stars in the Swan point toward the North Star. Notice, too, that the North Star is above Cassiopeia when it looks like a W and below it when it looks like an M.

Face south. Right in front of you the Scorpion lifts its long tail above the horizon. High to the east of it flies the Eagle.

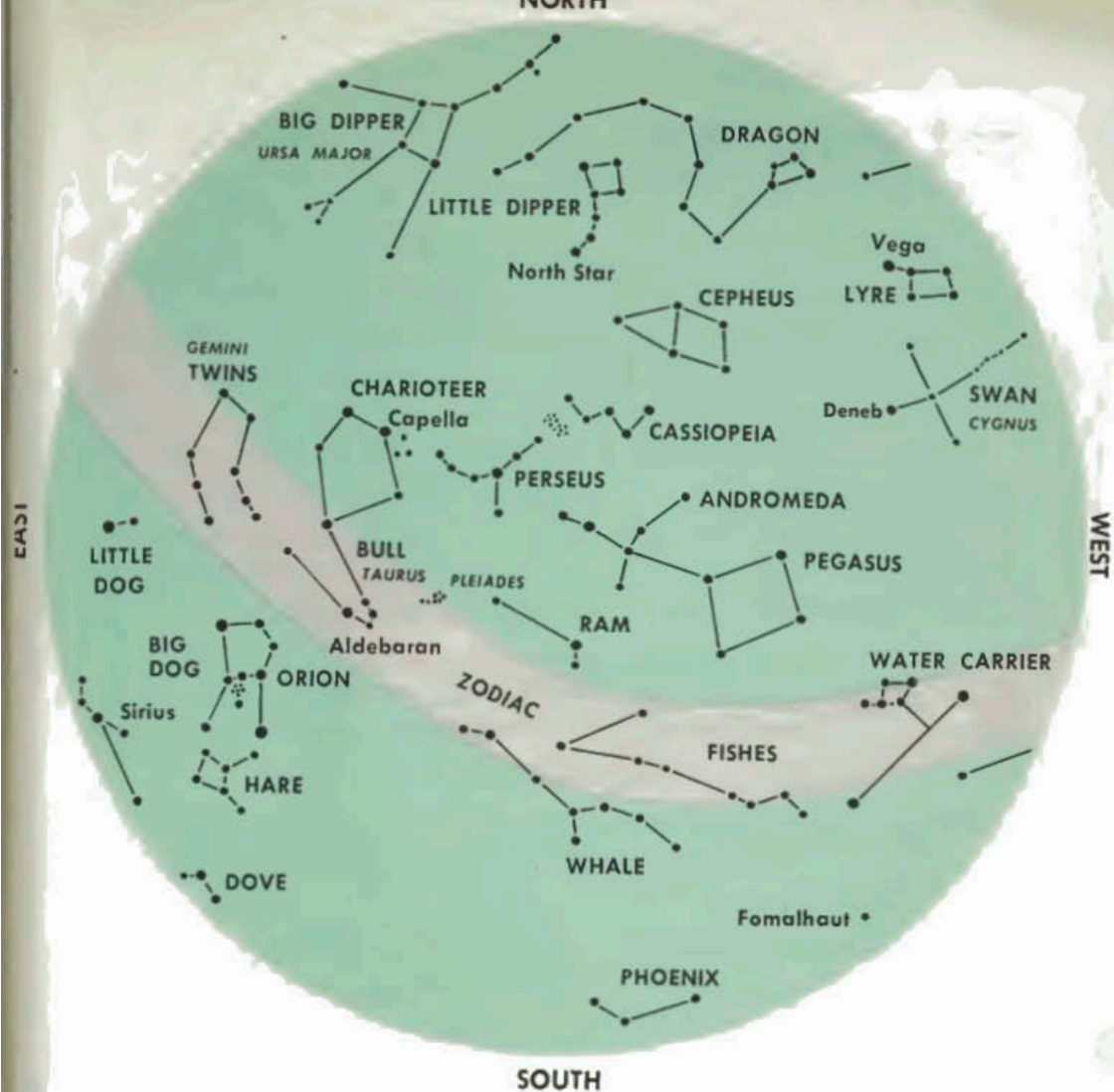

Winter Stars. On a winter's evening, start from the Big Dipper. Follow the pointers through the North Star and Cassiopeia till you strike a line of three stars in Andromeda. The star at one end of the line, with three more, form the Pegasus square.

The finest group of stars in the winter sky is Orion to the south. Draw a line upward through the three bright stars in the middle of Orion that form his belt. First you come to a red star Aldebaran, the eye in the V-shaped head of the Bull. Continuing you find the Pleiades—the Seven Sisters. If your eyes are good, you can count six. In a telescope, you'll see more than 200.

Back to Orion again. This time follow the line through his belt in the opposite direction till you hit Sirius. Next to our own sun, it is the brightest star in the sky.

WOODLORE

For the best possible camp experience you'll probably want to pitch your tent where there are trees. You are fortunate in this respect if you live in a part of the country where large areas are covered with forests. But even in sections where woods are few you may succeed in finding a campsite among trees.

In the beginning, the trees around you will be just trees—sheltering you against the wind, providing you with fuel for your fires and wood for camp improvements. But soon the trees will become your friends—and as with other friends, you'll want to know more about them, you'll want to call them by their names.

6 🍀 *Identify in the field 10 different kinds of trees or shrubs. Describe the area where each was found and the usefulness of each to its surroundings or to animals or to man.*

Knowing the Trees. You'll soon learn to know some trees by their shape—the Christmas-tree shape of spruces and pines, the vase shape of the elms. The bark will help you tell the sycamores, the birches, and beeches. You can't mistake the leaves of tulip, sassafras, sweet gum, and holly. You will have no trouble recognizing dogwood, magnolia, redbud, and locust by their flowers. You'll know still other trees by their fruits—the oaks by their acorns, maples by their winged seeds.

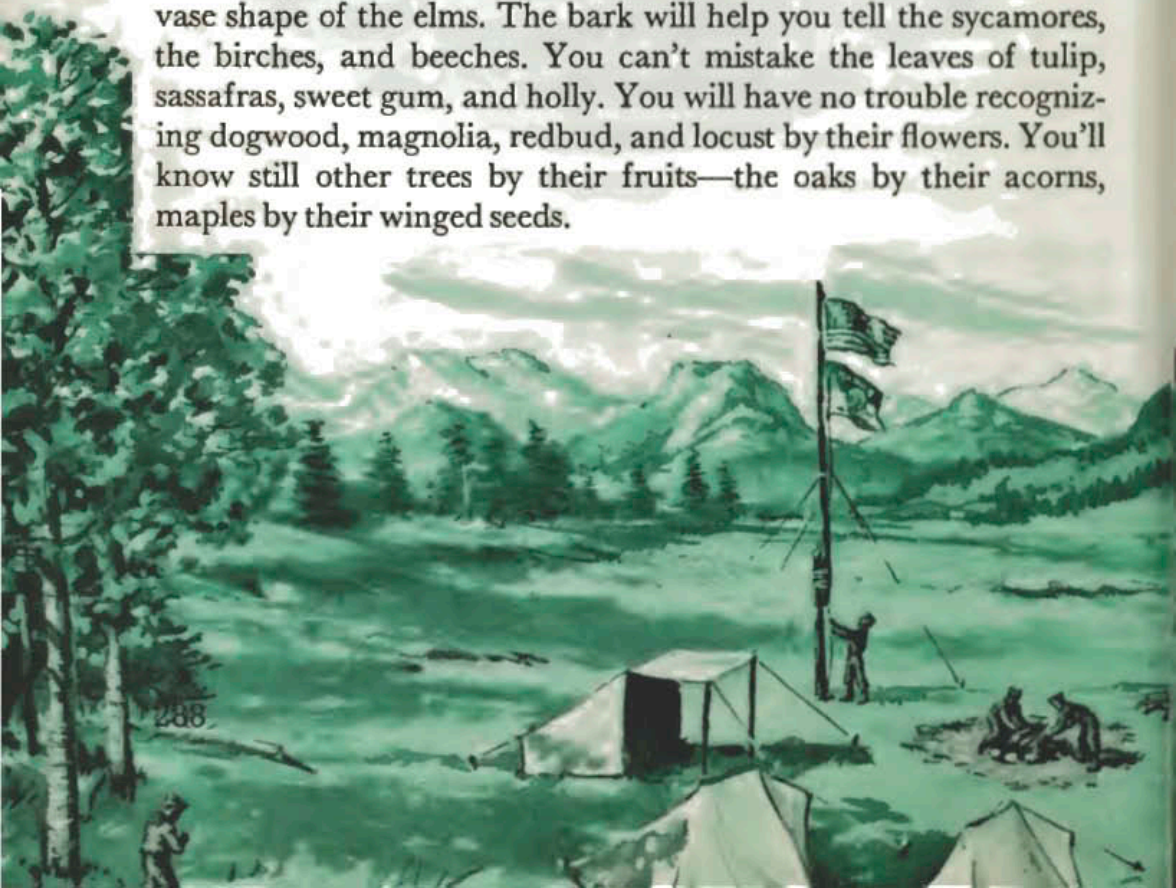

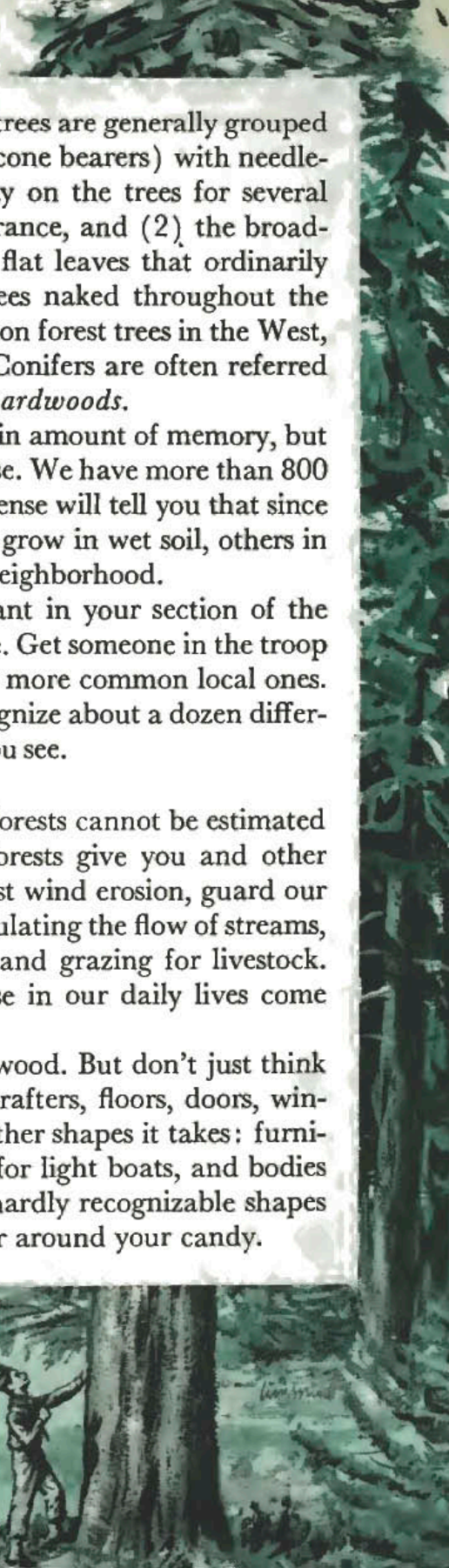

It will help if you remember that the trees are generally grouped in two large groups: (1) the conifers (cone bearers) with needle-like or scalelike leaves that usually stay on the trees for several years, giving them an evergreen appearance, and (2) the broad-leaved trees, with more or less broad, flat leaves that ordinarily fall off in the autumn, leaving the trees naked throughout the winter. The conifers are the most common forest trees in the West, the broad-leaved in parts of the East. Conifers are often referred to as *softwoods*, broad-leaved trees as *hardwoods*.

To name the trees you'll need a certain amount of memory, but an even greater amount of common sense. We have more than 800 different kinds of trees. Your common sense will tell you that since some trees like it hot, others cool, some grow in wet soil, others in dry, they won't all be growing in *your* neighborhood.

So find out which trees are important in your section of the country and forget the others for a while. Get someone in the troop who knows about trees to show you the more common local ones. You'll then discover that if you can recognize about a dozen different kinds you'll know most of the trees you see.

Using Our Forests. The value of our forests cannot be estimated in money. Besides the pleasure that forests give you and other campers, they provide protection against wind erosion, guard our watersheds by holding moisture and regulating the flow of streams, and give food and shelter for wildlife and grazing for livestock. In addition, numerous products we use in our daily lives come from the forests of America.

The most important tree product is wood. But don't just think of wood as fuel or building material—rafters, floors, doors, window sashes—think of it also in all the other shapes it takes: furniture, boxes, barrels, railroad ties, hulls for light boats, and bodies for special planes. Think of it in such hardly recognizable shapes as the newspaper you read, the wrapper around your candy.

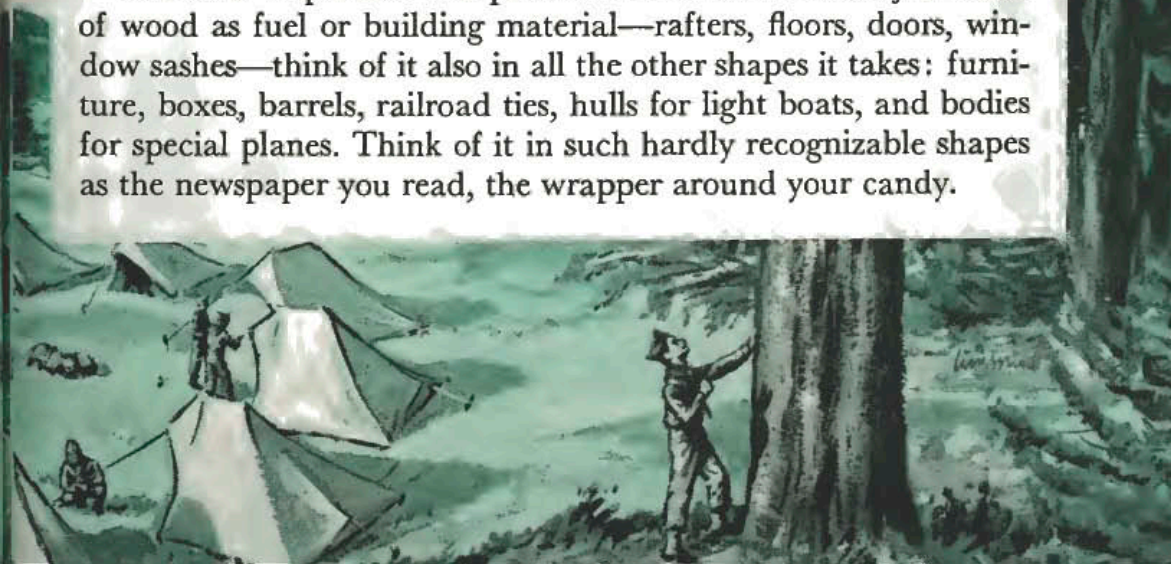

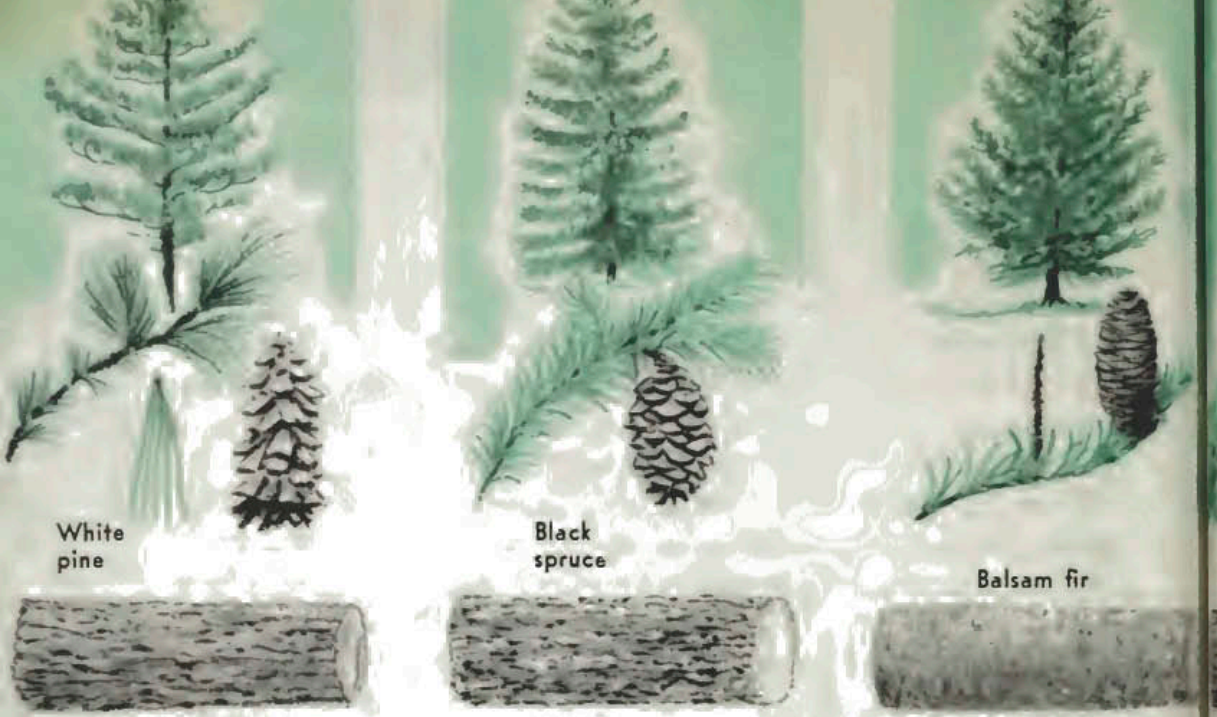

White pine

Black spruce

Balsam fir

And remember that other tree products are also important. Fruits and nuts are part of our food. The boiled-down sap of the sugar maple gives us maple syrup. Bark from some trees is used for tanning leather. Turpentine for paints comes from pine trees.

In spite of the fact that we all depend so much on trees, we have not always played fair with our natural treasures. Past gen-

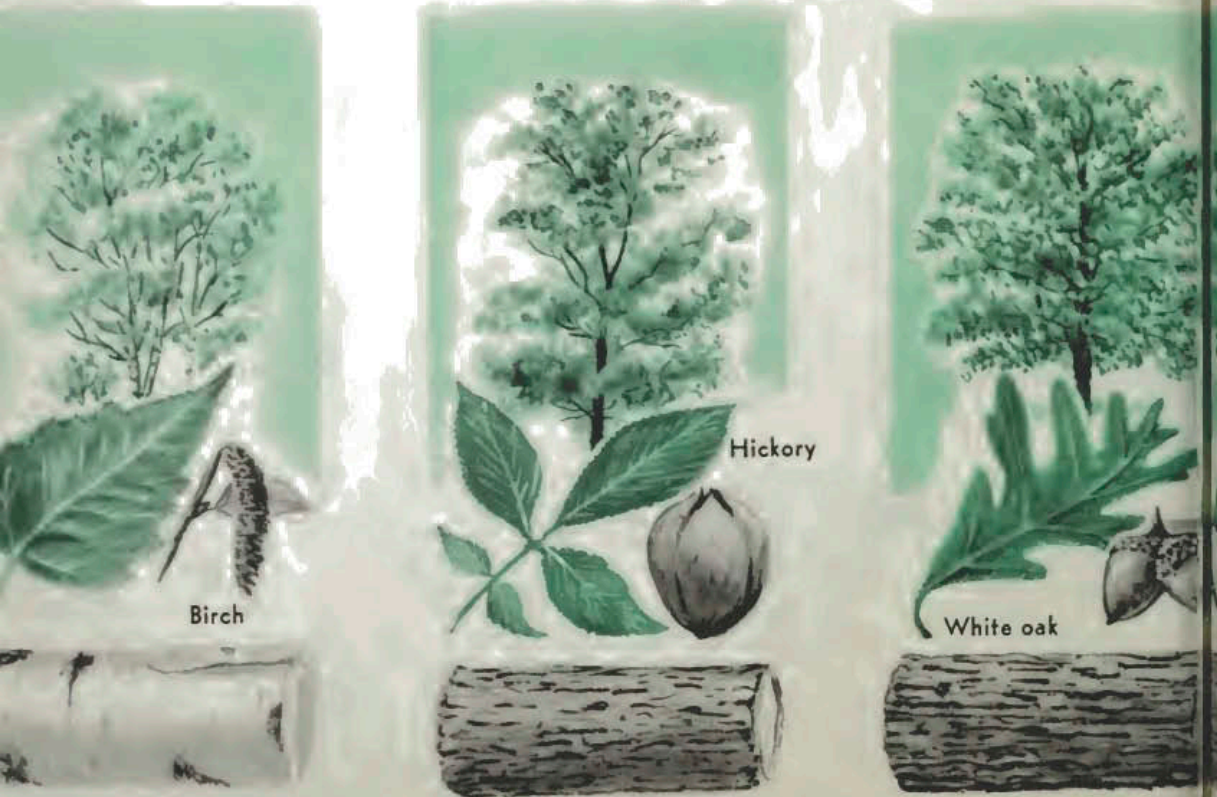

Birch

Hickory

White oak



Red cedar



Black willow



Poplar or aspen

erations of Americans have cut and burned and wasted a large part of our original heritage.

Fortunately, all America is waking up to the importance of our forests. As a Boy Scout you'll be in the forefront of those who are working today to "Keep America Green" and our forest resources secure for the future.



Live oak



Sugar maple



Green ash

EDIBLE PLANTS

In addition to the foodstuffs you bring from home you may be able to use foodstuffs that nature provides. It is a lot of fun to try to live off the land—making a meal of the fish you catch and the edible wild plants you find around camp.

7 🌱 Find at least four different edible wild greens, roots, buds, shoots, nuts, or fruits. Prepare and eat one of them selected by your leader.

SALADS AND GREENS

Salads and Greens. The woods and the fields are full of wild materials for salads and leafy, green vegetables.

292

Purslane



Pokeweed

Milkweed

Dandelion



Sheep sorrel



Water cress



Stinging nettle



Marsh marigold



Chicory



Black mustard



Lamb's-quarters



Watercress and sheep sorrel can be eaten raw. Other greens need to be cooked.

In the spring, cut the shoots of pokeweed and common milkweed when they are just a few inches high. Boil them in enough water to cover. When almost done, pour off the water, pour in fresh water, and boil again until tender. Serve like asparagus.

The same method of boiling in two changes of water is used for the tender tops of lamb's-quarters and stinging nettle, the young stems and leaves of marsh marigold and purslane, the young leaves of curled dock, black mustard, chicory, and dandelion. If you can't find enough of one variety, mix several kinds.

Edible Roots and Tubers. The crisp roots of Indian cucumber can be munched "as is." They have a pleasant, cucumbery flavor.

You'll get plenty of nourishment from the roots or tubers of arrowhead, cattail, prairie apple,

293



ROOTS AND TUBERS

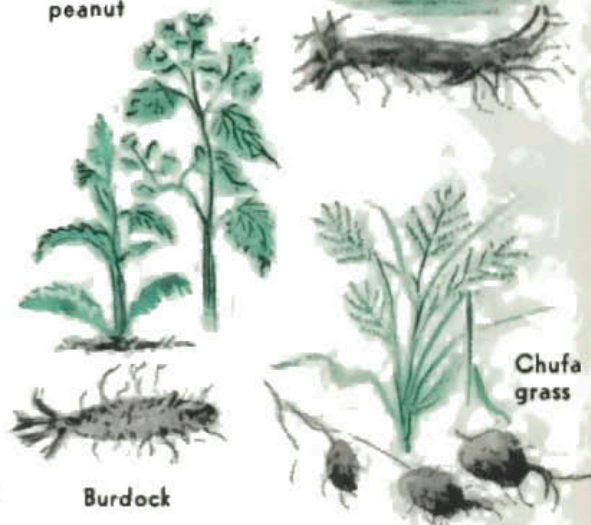

Prairie apple

Groundnut

Arrowhead



Staghorn
sumac

BEVERAGES



Black
birch



Wintergreen



Basswood



Spearmint

groundnut, hog peanut, wild potato vine, Jerusalem artichoke, chufa grass, and the first-year roots of burdock and evening primrose, dug up in the fall. In a pinch they can be peeled and eaten raw, but they are better boiled or roasted in the coals of your fire. For roasting, first wrap the roots in several layers of large leaves that have been soaked in water. The wet leaves will first steam the roots. Then, as the leaves dry out, the roots will be roasted.

Beverages. The red fruit clusters of staghorn sumac make a refreshing "pink lemonade." Steep them in enough cold water to cover, pour off the liquid, and sweeten to taste.

You can make a pleasant hot tea by pouring boiling water over the leaves of spearmint, peppermint, wild bergamot, over the flowers of elderberry and basswood, and over the twigs of spicebush.

Tea may also be made on the dried leaves of wild strawberry,



Bergamot



Spicebush



Elderberry

Raspberry

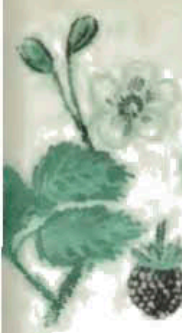

Blackberry



Strawberry



Blueberry



Cranberry

sweetbrier, black birch, winter-green.

Dried, toasted, and ground roots of dandelion and chicory are important coffee "stretchers" or substitutes.

Wild Desserts. When in season, you can't beat wild berries, fruits, and nuts for a flavorsome dessert.

Among berries and fruits, you'll like wild strawberry, red raspberry, blackcap, dewberry, huckleberry, blueberry, cranberry, wild grape, prickly pear. The ripe May apple fruit appeals to some. Papaw and persimmon are good after the first frost.

And don't forget the nuts of black walnut, butternut, pecan, hickory, hazel, chestnut, piñon, and Digger pine.

DESSERTS



Wild grape



Prickly pear



May apple



Papaw

295



Black walnut



Persimmon



Hazel

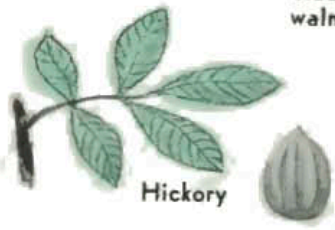

Hickory



Chestnut



Piñon



Butternut

GO SWIMMING

“Come on in—the water’s fine!” Next to “Come and get it!” that’s about the most popular yell in summer camp.

Can you think of anything better on a hot summer day than to dive into a cool lake for a refreshing swim? Hardly! So here we come!

The whole gang is going swimming. Everything is ready at the waterfront.

Before you came to camp you had your doctor give you a medical examination. The first day in camp your swimming ability was tested. Now you are buddied up with another fellow about as good at swimming as yourself. You are all set.

You and your pal check in at the buddy board with all the others. And there goes the whistle!

You dive or splash in. The race out to the raft is on. Up on it, off the diving board, up again, in again, everybody yelling.

Suddenly a whistle pierces the air and there’s a yell of “Buddy up!” The lifeguard counts to 10. You and your buddy quickly grasp hands. So do all the other buddy teams. The guard checks to see if all buddies are together. You’d better be! Otherwise you are out of luck—out of the water you go and no more swimming for the day. To break the buddy rule is one of the most serious offenses in camp.

Another blast of the whistle. “All right!” And the fun begins again, until the call of “All out!” sounds.

8a 🧭 *Tell what precautions must be taken for a safe swim.*

Every Scout a Swimmer. Well, how’s your swimming? Aim to become an expert swimmer—not just a splasher. That means plenty of practice and sticking close to the commonsense rules of water safety. They go like this:

1. Have a careful medical examination and follow your doctor’s orders.

2. Know your swimming ability and stick to the swimming place that fits your skill: waist deep for nonswimmers, up to shoulder deep for beginners, over the head for swimmers.

3. Always swim with a buddy. Keep him in sight all the time and within quick reach. You are his protector, just as he is yours.
4. Wait *1 hour* after a meal before you go in the water.
5. Follow faithfully and immediately all rules and orders given by the waterfront men.
6. NEVER dive into unknown water. NEVER take a dare to show off in the water. NEVER swim long distances unless someone goes along with a boat.

Learning To Swim. The first step in learning to swim is to get to feel confident in the water—confident that the water will keep you up. So, with a good swimmer standing by, wade into water waist deep, bend down, grasp your ankles with both hands and drop your chin on your chest. Instead of sinking, you will find yourself floating on top of the water. To get back to standing position, simply let go of your ankles and stand up.

Next comes your breathing. Breathing while swimming is different from your regular breathing—you have to breathe in through the mouth and out through mouth and nose. Try it. In waist-deep water, take a deep breath through your mouth, dip your head under water, and blow out slowly through mouth and nose. Repeat several times until you are good at it.

Now you can make your first plunge. Take a deep breath. Push

First step in learning to swim is to feel confident in the water. Standing in waist-deep water, grasp your ankles and you'll float like a jellyfish. Next, learn proper way to breathe.

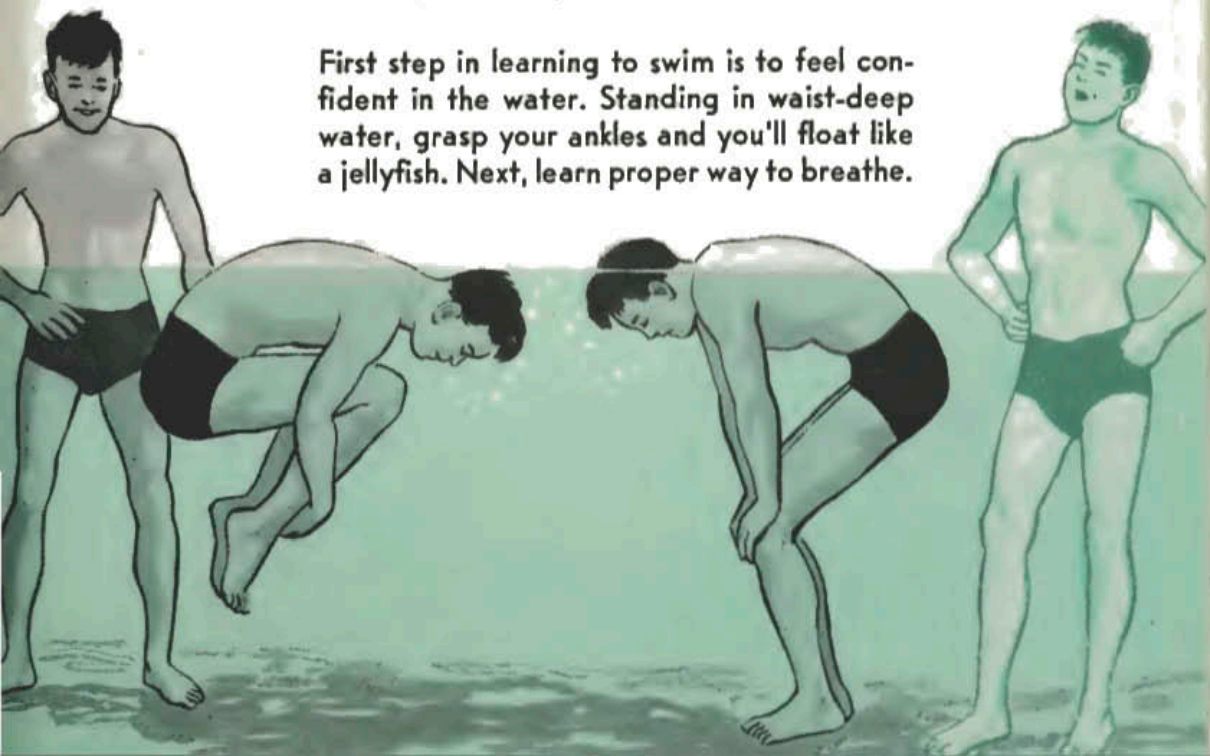



For your first plunge, take a deep breath and push off. You will be surprised to see how far you will get.

off from the bottom and plunge toward the shore, arms and legs extended, face in the water. You'll be surprised to see how far you can get.

Swimming the Crawl. A good stroke to use when learning to swim is the crawl.

You start by learning to kick your feet up and down. Get into water that's just deep enough for you to place your hands on the bottom when you lie down with your feet extended backward. Move the feet slowly up and down past each other, with legs straight, toes turned in. Speed it up. Then go out into waist-deep water. Take off for a plunge toward shore and kick slowly, powerfully, until you reach land.

Try the arm stroke on dry land before you use it in the water. Extend your right arm directly ahead from the right shoulder. Swing the arm straight down to the hip. Then raise elbow upward and extend the hand straight forward. Do the same with your left arm, then with both arms alternately. Go into chest-deep water, plunge forward, and pull yourself ashore, using arm stroke only.

Legs and arms together now! Plunge forward. Put the feet in

298



Breathe in by turning your face sideways. Practice a smooth rhythm.



Best way to learn to swim
the crawl stroke is to
begin with the leg kick.

action, then the arms. Use easy and slow movements—get your money's worth out of each stroke. Beat your legs six times for each full movement of the arms and make your breathing fit your stroke—turning your face sideways to breathe in, downward to breathe out.

8b 🍀 *Jump feetfirst into water over your head in depth. Swim 50 yards. During the swim, stop, make a sharp turn, and resume swimming.*

First Class Swimming. As soon as you know a swimming stroke you can try for the First Class swimming test. For this, you have to jump overboard feetfirst in water slightly over your head, swim 25 yards, make a sharp turnabout, level off, and return to the starting point. That's 50 yards altogether.

The First Class swimming test is just a start. To become a good swimmer, follow up with practice and still more practice. And don't stop with learning one stroke only—go in for side stroke, elementary backstroke, and breast stroke, in addition to crawl. You'll then be well on your way toward earning the Swimming merit badge.

299

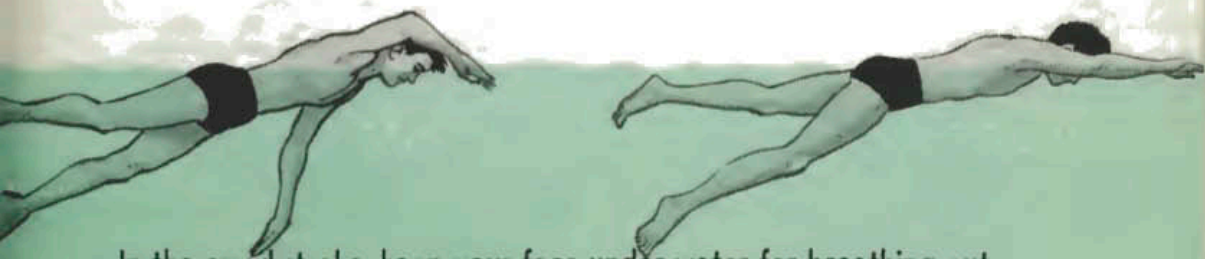

In the crawl stroke, keep your face under water for breathing out.



GET A MESSAGE THROUGH

In a fraction of a second, a message can speed its way around the world when transmitted by the latest electronic equipment. But with all the advances in communication have you noticed how difficult it is to convey your thoughts to your buddy so he understands exactly what you mean?

When you asked your little brother to do something for you and he did it wrong—was it your fault because you did not make him understand what you wanted? Your success in getting along with your best friend or being successful in a school or playing on a team depends on good communications, on being understood.

Your success in life may depend on your skill in communicating with the rest of the world. The Gold Quill Award, described on page 368 of this book, will help you get started.

Samuel Morse, who developed his widely used Morse code, added greatly to solving the communication problem. His system of dit-dahs is part of the communications of Scouting.

When you know signaling you are able to send a message from mountain to mountain, or across lakes. You can send for aid in a serious accident or for fighting a forest fire. You can help when regular means of communications break down in hurricanes, earthquakes, or floods. You can Be Prepared.

Signaling is for *stickers* only. It takes determination, practice, and patience to become a good signaler. But when you stick it out and become good, there's lots of fun to it.

9 🍀 *Send and receive a message of at least 20 words, using either international Morse or semaphore codes and necessary procedure signals.*

MORSE CODE SIGNALING

Learning the Morse Code. There's no quick trick to mastering the Morse code—it's a matter of settling down to learning it, letter by letter, until the whole alphabet sticks in your mind.

The principle of the Morse code is that every letter is made up of combinations of something short and something long. Each letter can be made by short or long sounds, short or long light flashes, short or long electrical impulses.

The quickest and most effective way of learning the Morse code is by sound. Get yourself a buzzer signaling kit, or put one together as shown in the illustration. Then line up a buddy to help you and go to work. Have your buddy send while you receive, then change over and have him receive while you send.

Learn the letters according to the frequency in which we use them in the English language:

ETAOINS HRDLUCM PFWVYB GJQKXZ

Break the letters up into groups of six or seven letters each and learn one group at a time until you recognize each letter quickly and without hesitation. Learn all the numerals at one time.

Get into the habit of a smooth, even rhythm. Make short buzzer sounds that will each sound like a snappy *dit!* and sounds three times as long that will sound like *dah!* Make the intervals between

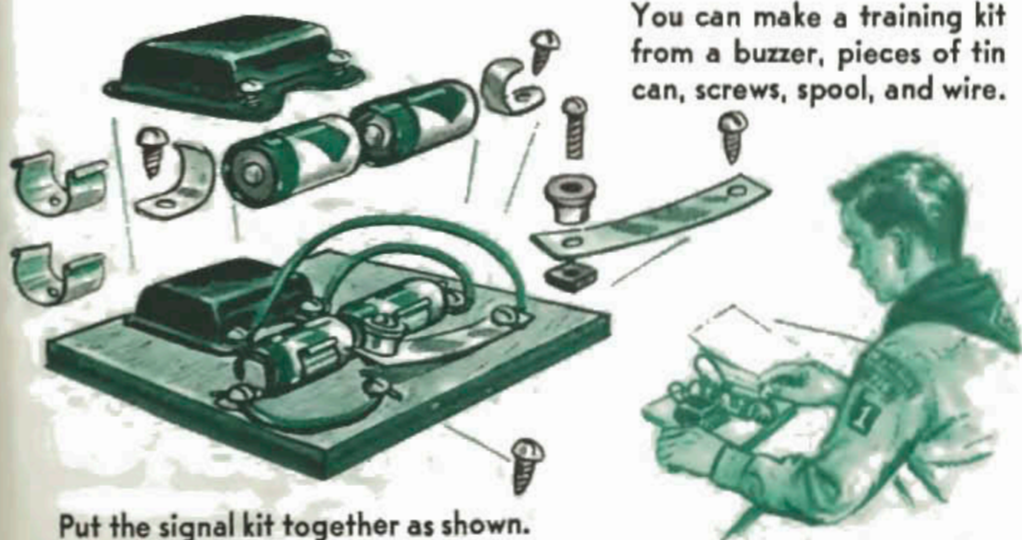

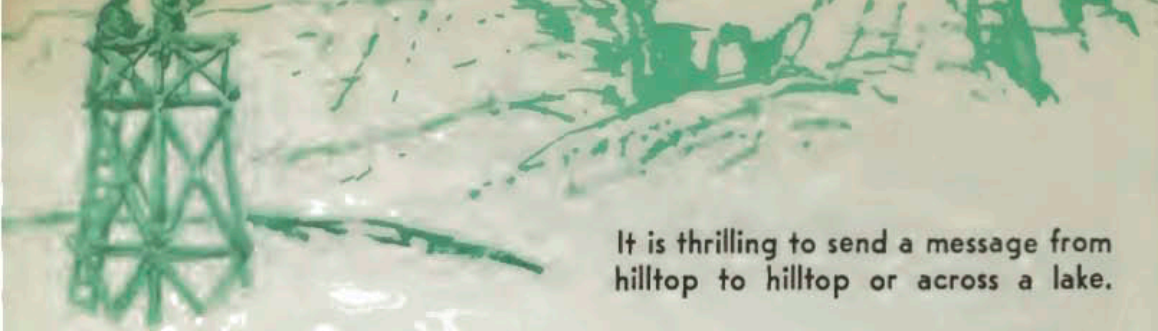

It is thrilling to send a message from hilltop to hilltop or across a lake.

dots and dahs the same length as a dit, the interval between letters three times as long.

As soon as you know a few letters, send and receive words.

When it has become simple for you and your buddy to receive all letters, start the slow sending of short messages. Always remember to divide the work evenly. It is easy to become lopsided—better in sending than in receiving. You want to be equally good in both.

For complete messages, it is not enough that you know the Morse code letters—you must also know a few *procedure signals* for getting a message through. In sending, you use the procedure signals for “attention,” “error,” “end of word,” “end of sentence,” “end of message.” In receiving, you’ll have use for the procedure signals for “go ahead,” “repeat,” “word received,” “message received.”

Using the Morse Code. As soon as you have mastered the Morse code, make use of it.

You’ll get a kick out of signaling games at patrol and troop meetings, but the real adventure comes when you use signaling outdoors—first at short distances, then some day over distances so great that you may need field glasses to see the sender.

The Morse code gives you several means of sending a message. In the daytime, you can do it by flags or by flashes from the sun in the mirror of a heliograph. At night you can use flashlight, auto light, or fire. By day or night you can send your message by whistle, bugle, auto horn, blinker, or short-wave radio.

Making Up a Signal Station. To do the job well, a signal station should consist of two Scouts.

When sending, one Scout dictates the message, word by word; the other Scout swings the flag.

When receiving, one Scout reads aloud the letters sent by the distant station; the other Scout writes them down on paper.

International Morse Code

Letters

A	di-dah	J	di-dah-dah-dah	S	di-di-dit
B	dah-di-di-dit	K	dah-di-dah	T	dah
C	dah-di-dah-dit	L	di-dah-di-dit	U	di-di-dah
D	dah-di-dit	M	dah-dah	V	di-di-di-dah
E	dit	N	dah-dit	W	di-dah-dah
F	di-di-dah-dit	O	dah-dah-dah	X	dah-di-di-dah
G	dah-dah-dit	P	di-dah-dah-dit	Y	dah-di-dah-dah
H	di-di-di-dit	Q	dah-dah-di-dah	Z	dah-dah-di-dit
I	di-dit	R	di-dah-dit		

Numerals

1	di-dah-dah-dah-dah	6	dah-di-di-di-dit
2	di-di-dah-dah-dah	7	dah-dah-di-di-dit
3	di-di-di-dah-dah	8	dah-dah-dah-di-dit
4	di-di-di-di-dah	9	dah-dah-dah-dah-dit
5	di-di-di-di-dit	0	dah-dah-dah-dah-dah

Procedure Signals

Used by **SENDER** (Letters with line over them sent as one letter)

Morse	Semaphore	Meaning	Explanation
— AAAA	Attention	Attention	I have a message for you. Are you ready?
8 E's	8 E's	Error	I made a mistake. I will repeat beginning with last word that I sent correctly.
Front or Pause	Front	End of word	End of word. More coming. (Front with flags; pause in other methods.)
— AAA	AAA	Period	End of sentence. More coming. (Punctuation is usually spelled out in long messages.)
— AR	AR	End of message	That's all for now; did you get it?

Used by **RECEIVER** (Letters with line over them sent as one letter)

Morse	Semaphore	Meaning	Explanation
K	K	Go ahead	I am ready to receive. Start sending.
— IMI	IMI	Repeat sign	Please send again; I missed it.
T	C	Word received	I understood word. TO BE SENT UPON RECEIPT OF EACH WORD (not used in telegraph and radio receiving).
R	R	Message received	I got it OK.

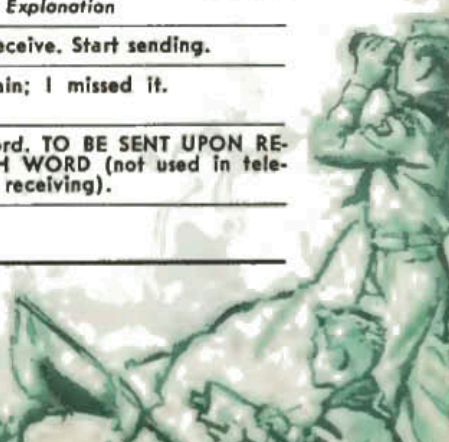

Wigwagging. The most common Scout method of sending a Morse message in the outdoors is by a single signal flag—swinging it to the right for a dit, to the left for a dah. That is called *wigwag*. The flag is about 2 feet square and is attached with tapes to a staff 4 to 6 feet long. In an emergency you can use your Scout neckerchief. Before you attempt to send a message, learn the right position with the flag and the right way to use the flag for making dits and dahs.

Face squarely the person to whom you want to wigwag. Spread the feet apart for a firm stand. Grasp the butt end of the staff with your left hand and hold it firmly against your belt. Place the right hand about a foot higher. Slant the staff forward a little. This is the upright position. It is used between letters.

To make a wigwag *dit*, keep the end of the staff in place with the left hand and, with the right hand, bring the flag down to the right, almost to the ground, then back again to upright position, pausing here. In this movement, in which you twist your body slightly to the right, the tip of the staff should make a figure 8 through the air to prevent the flag from getting wrapped around the staff. The *dah* is the same movement of the flag to the left and back to upright.



Swing flag to left to signal "dah." Use a figure-8 motion.



Use a dark flag when background is bright.



Flag held upright indicates the end of letter.



Letters with several dits or dahs must be made without stopping between the movements of dits and dahs. If you stop in the middle of A (di-dah), for instance, the receiver will read it as E (dit) and T (dah). So train in sending di-dahs and dah-dits by swinging the flag from one side to the other in large figure 8's.

Use front movement to indicate the end of a word. It is made by bringing the staff down in front of you until it almost touches the ground and up again to upright position.

Now, suppose you want to send a message to the Panther Patrol of Troop 5 camping on the other side of the lake.

First, attract the attention of the other patrol by the attention signal—AAAA, sent as one letter.

As soon as you are seen, the signaler of the Panthers gets out his flag and sends the letter K to show that he is ready to receive, and you begin your message.

Keep watching the Scout to whom you're sending the message. As long as he makes the letter E after each word you send, everything is all right. But if he suddenly sends the letters IMI as one letter, it means that he failed to understand you and wants you to repeat the last word.

If you make a mistake yourself in the middle of a word, bring

Swing flag to right to indicate "dit."
The figure-8 movement will prevent the flag from wrapping itself around pole.

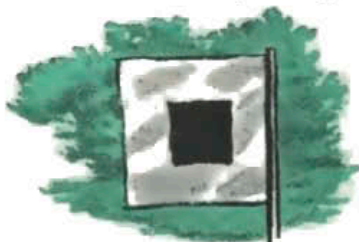

Use a light flag when the background is dark.



Flag down means end of a word.

You will be surprised at the distance over which a flashlight will carry your message at night.

your flag down immediately in a front movement, make eight dits—EEEEEEEEE—to indicate correction, another front, and start the word over.

Finish your message with AR sent as one letter and wait for the receiver to send the letter R. That tells you that he got your message. No message is considered sent until its receipt has been acknowledged in this manner.

Wait for an answer if you expect one.

Don't worry about speed in signaling. Speed will take care of itself as you practice with your buddy. The important thing is to get the message through. It is better to take your time and have the receiver read every letter, than to give him a hodgepodge that doesn't make sense. In a message of 20 words (100 letters) there should be no more than five errors and none to garble the meaning of the message.

Other Morse Signaling Methods. Instead of signaling with a flag, you can send a Morse message by sound or by light.

For signaling by *sound* when you are on a hike, you can use a whistle or a bugle. In camp you can rig up a loud-sounding buzzer or an auto horn. Make the sound for dah about three times as long as for a dit. The break between dits and dahs of a letter should be the length of a dit, the interval between letters the length of a dah. To make up a message, use the same procedure signals that you are accustomed to use when Morse signaling with flags.

Signaling at night by flashes of *light* is exciting. You can use a flashlight or an auto headlight. Make the dits and dahs and intervals the same length as in signaling with sound.



SEMAPHORE SIGNALING

Another way to send a message by flags is by the semaphore system. In semaphore signaling two flags are used. They are usually 18 inches square and divided diagonally into two parts, one red, the other white. The flags are tied about 2 feet long, with the red part at the top and next to the staff. Semaphore is the quickest method for sending a flag message, but it can only be used in the daytime, and only over short distances.

Learning Semaphore. Semaphore letters are formed by placing two flags at certain angles to each other. Each flag must be held so that the staff is a continuation of your forearm. Place the forefinger along the staff to make sure of this.

All movements take place in the shoulder joints, with the arms kept stiff. Whenever you cross a flag in front of you to make a letter, twist your body slightly in the same direction.

Get a buddy to help you from the start, so that he can check to see that you make the angles correctly. Learn the letters of the first "circle" group of letters, then send them to your buddy and try to make up words for them. Take up the next group and try to make up words for them. Take up the next group and so on through the list. Since it is harder to receive than send, you should have your friends send to you, more than half the time.

Sending the Semaphore Message. To send a semaphore message, get the receiver's attention with the *attention signal*, made by waving both flags repeatedly overhead in a scissor-like motion. When the receiver sends the letter K, then you can go ahead.

Send the letters of each word by going directly from the position



A

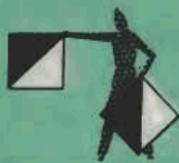

B



C



D

8



H

9



I



K



L



O



P

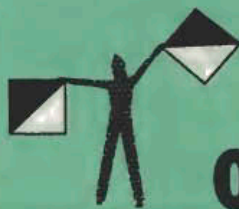

Q



R



T



U



Y

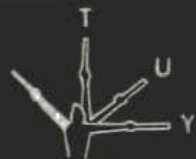

C CIRCLE



J



V



D CIRCLE



W



X



E CIRCLE



Z



F CIRCLE

Learn one "circle" at a time. Make up words and send and receive. Finally, send messages.

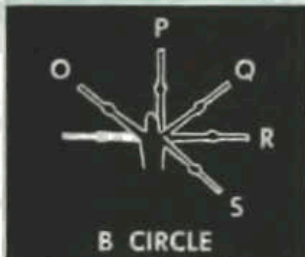
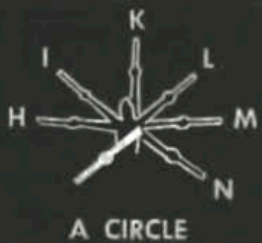

In the semaphore alphabet, letters are arranged in clock-like circles. Letters A to G ("grand circle") is made with one flag, the other at front. Other circles have one flag in A, B, C, D, E, or F position.

of one letter, without stopping, into the position of the next, pausing in each. If you have to think of the next letter, hold the letter you are making until the next one comes to mind.

To indicate end of word, give the *front signal* by bringing the flags down in front of you, with the staffs crossing each other.

Whenever double letters appear in a word, front is used to separate them. Make the first letter, then front, and immediately, without pause, bring the flags again in position of the letter.

The receiver acknowledges each word by sending C. If he suddenly sends IMI, it means that he did not catch your last word. You repeat it and continue from there. If you have made an error, yourself, you immediately send *eight E's* and start again from the beginning of the correct word you want to send. Finish the message with AR and wait for the receiver to make the letter R. Then you'll know that he has received your message correctly and can act on it.

ATTENTION signals message to come. **FRONT** separates words of a message. **NUMERAL** indicates numbers follow instead of letters.

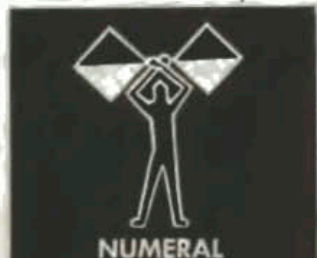



BE PREPARED FOR ACCIDENTS

To read a book you must first know the letters of the alphabet. It's the same with first aid. To go in for advanced first aid, you must first master the simple kind. To go in for First Class first aid, you must first make sure that you still know the first aid you learned for Second Class.

10a 🍀 *Show that you have retained your Second Class first aid knowledge by being able to demonstrate any of it asked for by your examiner.*

Review First Aid. So go back over the Second Class first aid section, pages 186 to 196. Test yourself on the knowledge, and have a buddy or your patrol leader try you out.

When you are sure of yourself, build on what you know and take the next step in learning first aid so that you will be prepared for any emergency that may happen.



SIMPLE WOUNDS

You already know that the proper care for a small wound consists in washing it and covering it with a sterile pad.

Whatever the size of the wound, think of this little rhyme:

Treating wounds, heed this reminder:

Clean it—dress it—put on binder.

CLEANING A WOUND—The best way to clean a wound is to wash it with soap and water. At home, use water out of the faucet. In camp or on a hike, use water from your canteen or from a clear stream or lake. If you don't have water, simply cover the wound with a dressing until water for washing is available.

DRESSING A WOUND—The dressing for a wound should be sterile—that is, free of germs. Your first aid kit for hike or camp should contain several of these dressings, each in a germproof envelope. Open the envelope carefully. Pull the dressing out by one corner and place it on the wound, making sure that the part of it that will touch the wound does not touch anything else first and thereby pick up germs.

PUTTING ON BINDER—When the wound is dressed, the dressing must be kept firmly in place. This is done with a binder—strips of adhesive tape, a gauze bandage, or a triangular bandage, such as a Scout neckerchief. A triangular bandage is sometimes used open, sometimes folded into a narrow binder: a cravat bandage.

10b 🌿 *Show how to use a triangular bandage for arm sling and as a binder for wounds on head, hand, knee, and foot.*

ARM SLING



ARM SLING—An arm sling is used to keep an injured hand or arm protected. Tie an overhand knot—"pig's tail"—at the point of the triangular bandage. Place the bandage over the chest, with the "pig's tail" at the elbow of the arm that is injured and one

TRIANGULAR BANDAGE FOR HEAD



HEAD BANDAGE—Dress the wound. Spread your triangular bandage out flat and fold the long edge into a 1½-inch hem. Place the bandage on the patient's head on top of the dressing,



end over the shoulder of the uninjured arm. Bring the other end of the bandage up to the other shoulder. Tie the two ends together on the side of the neck in such a way that the hand is held about 3 inches higher than the elbow.



with the hem over the forehead, close to the eyebrows. Tie the two ends in the back. Pull the point of the triangular bandage until bandage lies firmly over the head. Tuck point and free ends in.

HAND BANDAGE



HAND BANDAGE—After the wound has been dressed, place the patient's hand on the triangular bandage, with the wrist at the

KNEE BANDAGE



KNEE BANDAGE—Place dressing on the wound and hold it in place with the long edge of the triangular bandage. Wrap the

TRIANGULAR BANDAGE FOR FOOT



FOOT BANDAGE—Put dressing on wound. Place foot on middle of bandage, with heel at the long edge. Cover foot with point,



long edge. Fold point over. Wrap the long ends of the bandage around the wrist and tie them with a square knot. Tuck in ends.

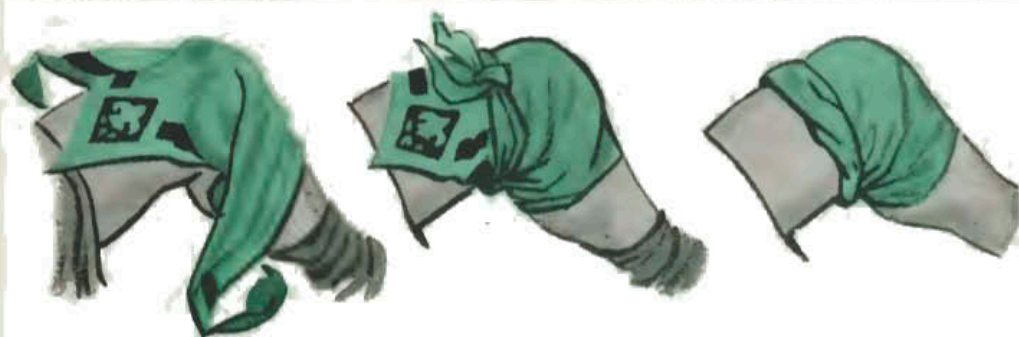

two long ends around the calf first, then around the thigh. Tie them together with a square knot and tuck them in.



fold in front corners and wrap ends of bandage around ankle. Tie the ends together and tuck them in.

PUNCTURE AND POISONED WOUNDS

10c 🌿 Explain first aid for puncture wounds from splinter, nail, fishhook, dogbite, poisonous snakebite.

Puncture Wounds. Puncture wounds are often deep but rarely bleed freely. They are sometimes small—as when made by a pin, a splinter, a nail, or a fishhook. Stab wounds and wounds from gunshot, blank cartridges, or firecrackers are in the same class. All of these wounds are dangerous—partly because they are hard to clean, but more particularly because the germs of the dreaded tetanus or lockjaw infection may have been carried into them. This germ is found in dirt around gardens, fields, and barns.

FIRST AID FOR PUNCTURE WOUNDS—Squeeze gently around the wound to get it to bleed. If a splinter or a nail is in the wound, pull it out. If it is a fishhook, it must be pushed in and around with a pair of pliers until the point comes out, and the barb must be snapped off with the pliers before it can be pulled out—better let a doctor do this. Treat the wound as a regular wound: Clean it—dress it—put on binder.

Then take your patient to a doctor. If it is needed, he will give the patient an injection of tetanus antitoxin or a booster shot of tetanus toxoid that will prevent the disease from developing.

Dogbite. A dogbite is not an ordinary wound, but one that requires the services of a first-aider, a doctor—and a dogcatcher!

🐍 SNAKEBITE



Cotton-mouth moccasin



Copperhead



Rattlesnake

In poisonous snakebite, swelling starts almost immediately. Tie a constriction band about 2 to 4 inches above the bite.

This is why: The biting dog may be just a nervous pet or a vicious brute, but it is possible that it may be mad—suffering from a disease called rabies or hydrophobia that may cause death to the person bitten. Cats, skunks, foxes, and other animals can have the same disease. There is no way of telling without a laboratory test. The dog may not *act* mad at all. It may seem perfectly normal or may snap at everything or may be partly paralyzed. The only way to find out is to have the animal caught and kept under observation. If it shows signs of sickness it may be necessary to have it shot (NOT in the head) and to have a laboratory analyze its brains. But that is not your job. Your job is to give first aid, to call a doctor, and to have someone—preferably the police—take care of the animal.

FIRST AID FOR DOGBITE—Wash the bite thoroughly in plenty of water—preferably under a water faucet—to remove saliva. Be careful not to get saliva on your own hands. After washing, cover the bite with a sterile dressing. Then to the doctor.

Snakebite. Both harmless and poisonous snakes are apt to strike when cornered. Ordinary first aid for wounds should be given in case of bite by a nonpoisonous snake. Since there is some danger of tetanus, the victim should have medical attention. Fainting may occur because of the emotional upset.

We have four kinds of poisonous snakes in the United States—rattlesnakes, copperheads, cottonmouth moccasins, and coral snakes. The bites of the first three look alike. In each of them you



Apply cold packs to the affected part of the body to help relieve the pain and possibly delay the spread of venom.

will find one or two marks that show where one or both fangs entered and injected their poison. A swelling starts almost immediately, the pain is intense, and shock is present.

FIRST AID FOR POISONOUS SNAKEBITE—Have the victim lie down at once and remain absolutely quiet; try to control his excitement. The affected part of the body should be lower than the rest of the body. Give first aid for shock along with first aid for the bite.

Apply a constriction band about 2 to 4 inches above the bite wound if it is on an arm or leg. The band should be tightened moderately to allow the fingers to be pushed between the skin and the band. A constriction band is *not* a tourniquet. It should be loosened for 30 to 60 seconds every 15 minutes.

Apply cold packs to the affected part of the body to relieve pain and possibly delay the union of snake venom with body tissues.

Transport the patient in a lying-down position to a doctor. Have someone telephone ahead to alert the physician when you will arrive and ask about antivenin, the antitoxin. Doctors and some hospitals do not have antivenin. For that reason it is important to tell the doctor or his representative that you are bringing in a snakebite victim. Then he can call for the antivenin and perhaps have it delivered by the time you arrive.

In desperate cases when you cannot get medical attention or medical advice by telephone, treat as follows: Sterilize a sharp

HEAT EXHAUSTION



In heat exhaustion, patient's face is pale, with cold sweat on forehead. Move patient to a shady spot. Place him on back with head low.

knife or razor blade and apply antiseptic to the skin. Open the wound at the fang marks by making shallow cuts— $\frac{1}{4}$ inch long—in the skin. Cuts should only break the skin and not go deep. Apply suction by mouth or by a suction cup for 30 to 60 minutes.

Do everything you can to make your patient comfortable. Be calm and reassuring.

HEAT, COLD, AND PAIN

10d 🌿 Describe how to recognize and care for victims of heat exhaustion, sunstroke, frostbite.

Heat Exhaustion. Heat exhaustion—as the name indicates—is caused by heat. It usually hits a person in an overheated room, but may also overtake him in the sun.

The patient's face is pale, with cold sweat on the forehead. Breathing is shallow. The whole body may be clammy from perspiration. Vomiting is common. Do not confuse with *sunstroke* which requires an entirely different kind of first aid.

FIRST AID FOR HEAT EXHAUSTION—Since heat exhaustion may be considered *shock from heat*, regular shock treatment is in order. Move the patient to a shady, cool spot, and place him on his back with head and shoulders low. If possible, get him into bed. Give him sips of salted water—1 teaspoon of salt to a glass of water.

SUNSTROKE



In sunstroke, patient's face is red and dry. Get him into shady spot. Place him on back with head raised. Cool him with plenty of cold water.

Sunstroke. Sunstroke is usually caused by exposure to direct sun. It is always serious, and a doctor should be called at once.

The patient's face is like the sun: red, hot, dry. Breathing is slow and noisy—sometimes it sounds like snoring. The body skin feels dry and hot. In severe cases, patient may be unconscious.

FIRST AID FOR SUNSTROKE—While waiting for the doctor, get the patient into a cool, shaded spot, and place him on his back with his head and shoulders raised. Undress him down to his underwear and set out to cool him—especially his head—with cold water or ice if you can get it. Use dripping wet towels, shirts, cloths—keep them cool by pouring water over them or wringing them out in cold water from time to time. If you have a sheet, spread it over the patient and keep it doused with cold water. When the patient's body has cooled, stop treatment for a while to see if he heats up again. If he does, resume cooling. When he regains consciousness, let him drink all the cold water he wants.

Frostbite. When you are out skating or skiing, someone in the crowd may complain of his ears, nose, fingers, or toes feeling numb. Or you may notice that fellow's ears or nose or cheeks are looking grayish-white—sure sign of frostbite.

FIRST AID FOR FROSTBITE—Get the frozen part thawed out. If part of the face is frozen, have the person remove a glove and cover the part with his hand. If a hand is frostbitten, bring it under the armpit next to the skin. Then get the victim into a warm room, give him a warm drink, and rewarm the frozen part by holding it in lukewarm but not hot water, or by wrapping it in warm blankets. When the frostbitten part is rewarmed tell the patient to exercise injured fingers or toes.

10c 🍀 *Explain danger of taking laxative for a stomachache.*

Stomachache. There are stomachaches and STOMACHACHES. There are those that come as nature's punishment for overeating or eating too fast, or for indulging in a diet of green apples, too much watermelon and ice cream, too many frankfurters and pop. And there is the kind that strikes with no apparent cause and continues for hours.

FIRST AID FOR STOMACHACHE—If it is plain that the ache is caused by improper eating, simply have the patient lie down or send him to bed. Half a teaspoon of baking soda in half a glass of water may relieve the pain. Use no laxative.

If the cause of the pain is unknown, or the ache continues, put the patient to bed and call a doctor—the trouble may be caused by an infected appendix. By all means **GIVE NO LAXATIVE**—the action of a laxative may break the appendix and make the patient's condition extremely dangerous.

FRACTURES OR BROKEN BONES

An automobile smashup, a fall, a violent blow, and you may be up against a fracture—a broken bone.

10f 🌿 *Demonstrate first aid for fracture of collarbone, upper arm, forearm, lower leg.*

Simple and Compound Fractures. There's your patient, obviously suffering from shock, complaining of pain in a certain spot of the leg, arm—or maybe head, side, or back. A quick check shows that a bone is broken—the patient can't move the hurt part; it may look bent or shortened or have a bump. If touched, the patient will register increased pain. A swelling is setting in.

If that is the general picture, your patient is lucky. His fracture is a simple fracture—one in which there is no open wound. It will heal in a few weeks. But if the sharp edges of a splintered bone have cut through flesh and skin to the surface, your patient is suffering from a compound fracture—a fracture plus a wound. Several months in the hospital may be necessary to heal it.

The terrible danger in fractures is that incorrect handling by a well-meaning first-aider may turn a simple fracture into a compound fracture that may cripple the patient or even endanger his life. So in fractures, what you **DO** is only part of the picture—what you **DO NOT** do is often far more important!



Simple fracture

Compound fracture

FIRST AID FOR FRACTURES

DO let the patient lie with as little motion as possible exactly where he is while you render first aid—making him as comfortable as possible with something over and under him, such as coats or blankets.

DO call a doctor or an ambulance immediately.

DO treat for shock.

COUNT TO THREE 1. Make patient comfortable.

IMPORTANT: In a compound fracture, cover the wound with a sterile dressing. If blood is spurting from an artery, stop it with hand pressure as described on page 190. It is good practice

SPLINTS

Splints. In case of extreme emergency—when an accident has happened on a heavily traveled highway or in faraway wilderness—it may be necessary to move the patient before the doctor gets to him. In such a case, **DO** support the broken limb by making it immovable between well-padded splints. **DO NOT** move the patient before this splinting is completed—**SPLINT HIM WHERE HE LIES!**

A splint is some stiff material that can be tied to the fractured limb to make it rigid and prevent the bone from moving and tearing the flesh with its sharp edges. A splint should always be longer than the bone to which it is applied. Before applying, the splint should be padded with soft material.



Materials for splints: boards, sticks, umbrella, paper, cardboard tube

DON'T let anybody bundle your patient into a car to rush him to the hospital—that's the simplest way of turning a simple fracture into a compound one, 10 times more dangerous!

DON'T try to set the broken bone—that's the doctor's job.

DON'T give a stimulant if there is severe bleeding.

2. Treat for shock.

3. Wait for doctor.

always to put a tourniquet bandage (see page 191) loosely around a limb with compound fracture—if bleeding should start, you are immediately prepared to handle it.

For splints use slabs of wood or lengths of saplings, pieces of bark, canes or umbrellas, broomsticks or shovel handles, rulers, heavy cardboard, signal-flag sticks, heavy wire, wire netting, cornstalks, folded newspapers or magazines.

For padding use cotton or wool batting, moss or grass, stockings or pieces of clothing, pillows or blankets, crumpled paper. Padding makes splints fit better and prevents hurting the patient.

—For tying the splints use neckerchiefs, handkerchiefs, roller bandages, strips of cloth, belts.

In other words, look around, see what is there, use what can be used. Try it this very minute, as you read this. What is within reach that you could use for splints and padding?



Materials for padding: clothing, crumpled paper, pillows, grass, moss

COLLARBONE FRACTURE



COLLARBONE FRACTURE—No splint necessary. Place the forearm in a sling with the hand raised a couple of inches higher than the elbow and tie upper arm against the side of the body with a wide cravat bandage. Make sure the bandage is not so tight that it stops the circulation in the arm.

UPPER ARM FRACTURE



UPPER ARM FRACTURE—Use one padded splint only, slightly longer than distance from shoulder to elbow. Fasten it on outside of arm. Place forearm in narrow sling and tie the splinted upper arm against the side of the body with a cravat bandage.

THIGH FRACTURE



THIGH FRACTURE—Use two padded splints, one for outside of leg extending from heel to armpit, and one for inside

FOREARM FRACTURE

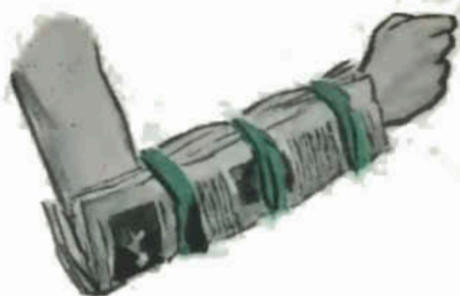

FOREARM OR WRIST FRACTURE—Use splint of magazine or thick newspaper. Or use two padded wooden splints, as long as distance from elbow to finger tips. Place one on inside of arm, the other on outside, and bind together. Place arm in wide sling with the thumb up and the hand a couple of inches higher than the elbow.

LOWER LEG FRACTURE



LOWER LEG FRACTURE—Use two padded splints, as long as the distance from middle of thigh to just beyond the heel. Place one on each side of injured limb and bind together, using at least four binders.

from heel to crotch. Bind together, using four binders around splints and leg and three around upper part of the outside splint and the body. **NOTE:** Because of the strength of the muscles of the upper leg, they often pull the broken parts of a bone out of line and into the flesh. For this reason the method given is early emergency care only. The patient should not be moved any great distance without a so-called traction splint. Ambulances carry such splints; doctor will bring one if told of thigh fracture.



Use walking assist if patient is not seriously hurt and is able to walk with a little help.



If patient is unable to walk yet not seriously injured, you may be able to carry him piggyback.

Transportation of an Injured Person

The transportation of an injured person requires a lot of common sense and care. There is, obviously, a great difference between helping John home from the playground with a sprained toe and getting a man with a broken back down from the mountain where he suffered his injury. One case is simple, the other extremely dangerous.

10g 🍀 *Tell under what circumstances an injured person should or should not be moved.*

Handle With Care. A SERIOUSLY INJURED PERSON SHOULD BE MOVED BY A FIRST-AIDER ONLY IN CASE OF EXTREME EMERGENCY, and then only after having received first aid and having had possible fractures splinted.

FRACTURE OF BACK OR NECK—The most dangerous fracture

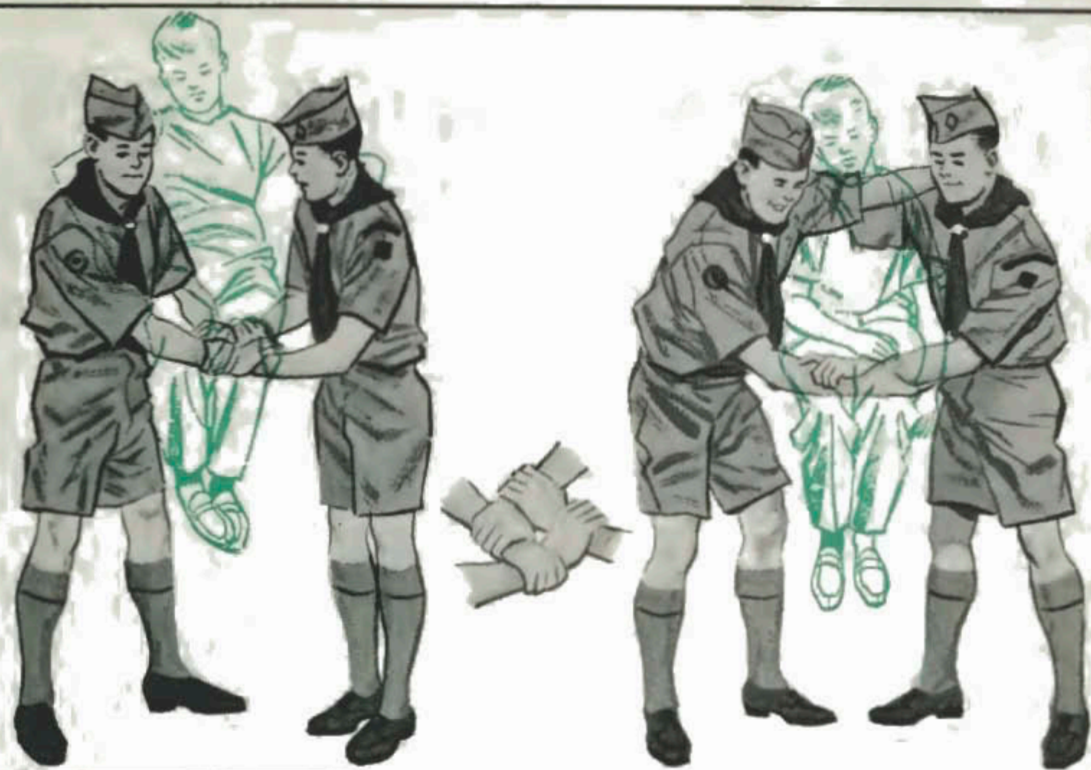

of all! It often occurs in an automobile smashup and may occur when someone dives headfirst into unknown water. Severe pain, often unconsciousness, and paralysis of legs or arms. *The slightest false move may cause the broken bone to cut into the spinal cord, killing the patient instantly, or injuring him so that he will be a paralyzed cripple for life. So: DO NOT MOVE HIM! WAIT FOR DOCTOR OR AMBULANCE!*

10h 🍀 *Demonstrate walking assist, one-man and two-man carries.*

Assists and Hand Carries. WALKING ASSIST—A patient who has suffered a minor accident and feels weak may be assisted to walk. Bring his arm up over your shoulder, holding onto his hand with one of yours, and place your free arm around his waist.

ONE-MAN CARRY is best done piggyback. Bring your arms under the patient's knees; grasp his hands over your chest.

FOUR-HAND SEAT is a good method for two first-aiders to carry

STRETCHERS

Two Scout shirts and two poles will make a strong stretcher. Shirts are used inside out, with all the buttons buttoned.

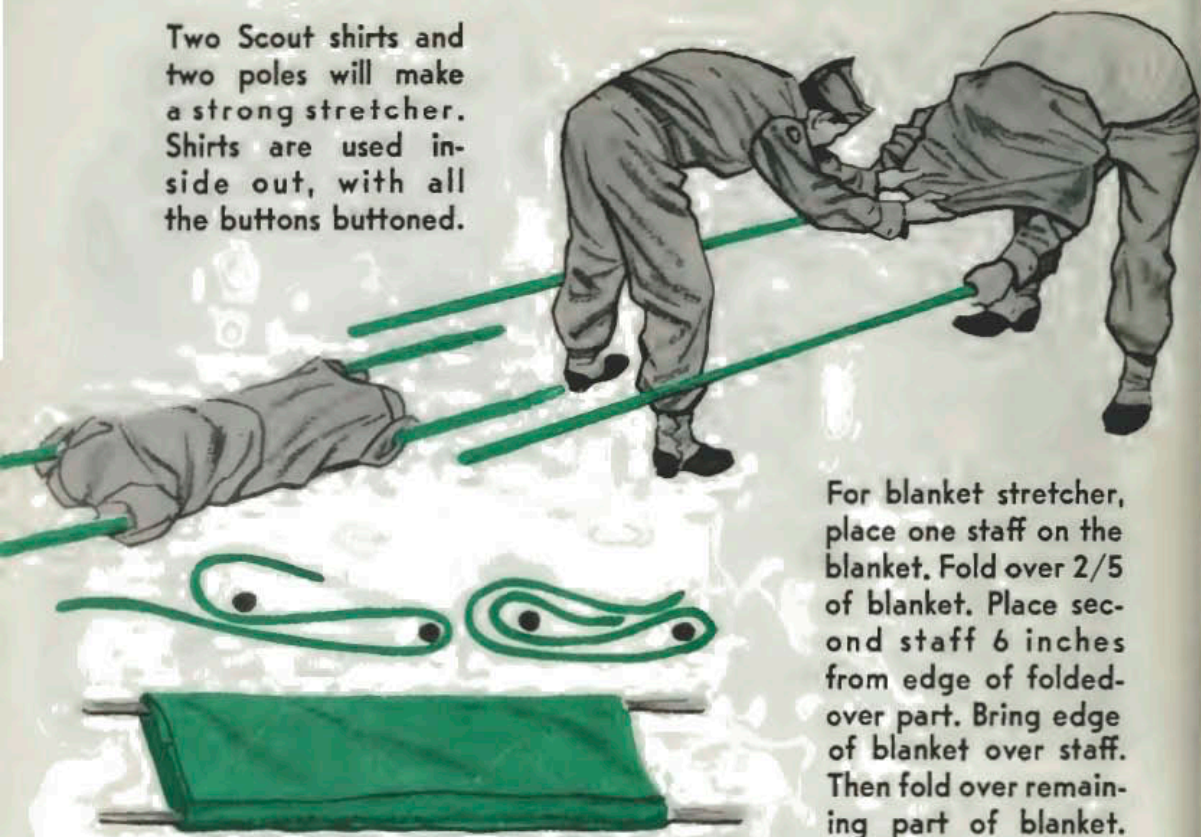

For blanket stretcher, place one staff on the blanket. Fold over 2/5 of blanket. Place second staff 6 inches from edge of folded-over part. Bring edge of blanket over staff. Then fold over remaining part of blanket.

a conscious patient. Each bearer grasps his own right wrist with his left hand, whereupon the two bearers lock hands with each other. The patient places his arms over bearers' shoulders.

TWO-MAN CARRY can be used when patient is unconscious. Bearers kneel on each side of the patient. Each bearer brings one arm under the patient's back, the other under his thighs. The bearers grasp each other's wrists and shoulders and rise from the ground with the patient.

10i 🧑‍🚒 *Improvise a stretcher and, with helpers under your direction, transport a presumably unconscious person.*

Stretchers. When the patient has to be moved for some distance or his injuries are serious, he should be carried on a stretcher.

A not too heavy door, a short ladder, or a gate will make a

If you have no poles for making stretcher but have the whole patrol on hand, you can use a blanket carry.



Place patient on blanket. Roll up edges of blanket close to the patient. Kneel down. Lift by grasping the rolled blanket edges.

satisfactory stretcher if padded with blankets or straw. If no such easy solution suggests itself, make a stretcher from two poles a couple of feet longer than the patient is tall and material suitable for making a supporting bed between them.

For stretcher poles use strong saplings, lengths of pipe or boards, long tool handles, oars.

For the bed part use two or three Scout shirts or coats turned inside out and buttoned up (push the poles through the sleeves); blankets, burlap bags or sacks (with holes cut in bottom corners), chicken wire, rope.

Whatever you use, *the strength of a stretcher must be tested before the patient is placed on it by trying it out with an uninjured person as heavy as the patient.* Otherwise, a collapsing stretcher may cause further injury to the patient.



SCOUT SPIRIT

Some time ago, 3,000 Scouts put on a great pageant in one of our large cities. They called it "The March of Scouting." In a number of exciting scenes the Scout actors showed the spirit of Scouting through the ages: Here were Spartan boys of old Greece participating in body-building exercises, youths of the Middle Ages preparing for knighthood, Indian youngsters learning the woodcraft skills of their tribes, pioneer boys helping build a country.

It was a thrilling spectacle staged with enthusiasm and precision by vigorous, wide-awake Scouts. As you watched it, you couldn't help thinking—

"What a nation we could build with youth as physically fit as the ancient Greeks, as mentally awake as our Indians and early pioneers, as morally straight as the knights of old!"

And why not? That's what Scouting is aiming for! That's the goal that every real Scout is working toward.

LIVING THE SCOUT IDEALS

Your Duties as a Scout. The Scout Oath is a clear statement of good citizenship. You learned it as a Tenderfoot Scout and explained the three great duties it contains in your own words. You have probably repeated it a number of times since at special cere-

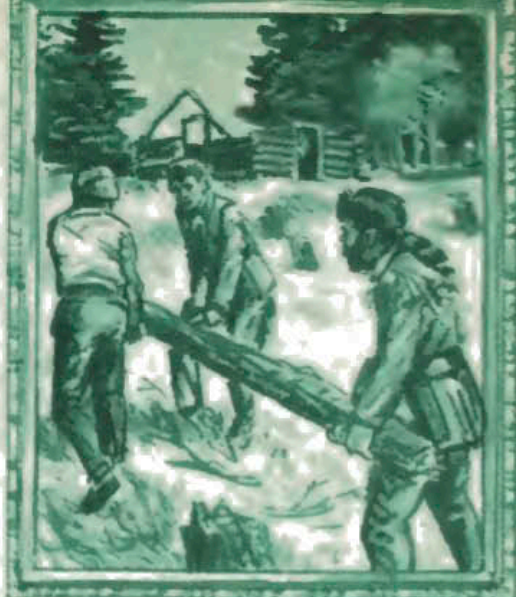

monies and have pledged yourself to it anew as a Second Class Scout. Now, as you prepare yourself to move into First Class rank, you need to deepen your understanding of it; you need to realize more fully that, as a Scout, you have a duty to perform for every privilege you receive.

You have the privilege of life—what is your duty as to its use? You have the privilege of citizenship in these United States—what obligation goes with that? You have friends—what duty does that place upon you? You have your own talents—what obligation do they carry for their development and use?

11 † *After completing the . . . tests, meet with your Scoutmaster (or an adult assigned by him) in a personal conference. At this meeting, complete to his satisfaction the following:*

a. *Discuss your ideas about the meaning of the Scout Oath (or Promise), the Law, motto, and slogan and give examples to show that you do your best to live up to these ideals in your daily activities.*

Three Points. As you try to do your best to live the Scout Oath, think through these great duties:

DUTY TO GOD AND COUNTRY—what is your obligation to God? What is your duty to your church? To believe in God? Of course—but more than that: To prove your faith in your daily deeds, to follow the teachings of your parents and religious leaders.

What is your duty to America? What do you owe the land that

gives you free education, things to enjoy and do, the chance to be what you want to be? To obey her laws? Yes. To respect her institutions? Yes—but more: To live for America as willingly as thousands of patriots have been eager to die for America. To die for one's country calls for supreme courage—but to live for it, to work, to produce, to help, to save, to obey the nation's laws, to be trustworthy, loyal, helpful, friendly, courteous, kind, obedient, cheerful, thrifty, brave, clean, and reverent, day after day, calls for courage over a longer time—and that is good citizenship.

DUTY TO OTHERS—What is your duty to other people? What do they have a right to expect of a Boy Scout? That you shall be friendly? Yes—all citizens expect that from each other. That you shall be fair? Yes, of course—but more than that. People know that the Scout promise to Do a Good Turn Daily means that a Scout helps others without thought of return.

DUTY TO SELF—What is your duty to yourself? What is your obligation to the man you hope to be? You need to grow in stature, in strength, in knowledge, into greater value and usefulness and skill. You need to Be Prepared for whatever life has in store for you. How? The last words of the Scout Oath point the way. They show you the duty you owe to yourself—to keep yourself physically strong, mentally awake, and morally straight. Only when you do that can you have the full measure of fun and happiness and joy from living.

... To Help Other People at All Times ... One of the simplest tests you can give yourself to find out what kind of Scout you have become is to ask yourself, "Do I do a Good Turn daily? Do I go out of my way to help other people?" When once the Good Turn habit has become part of your life your eyes see where help is needed; your mind tells you to go into action; your training as a Scout gives you the ability to help. But also, your eyes get to see and your mind to realize that some Good Turns are beyond a single person. And so you pitch into service projects.

11b  Describe at least one service project in which you have taken part since becoming a Scout and explain how you think it helped others.

Service. Some of these projects may be large-scale Good Turns to your school, your church or synagogue, or to your community—ranging the whole way from usher service at a rally to cleanup of a public park. Some of the projects may have national significance. A number of them will probably have to do with conservation—from stream improvement to forest planting.

Whatever it happens to be, your patrol and your troop will know that you will want to be in there doing your part.

Onward in Scouting

11c  *Discuss the adventure and vocational exploration of the merit badge plan. Look over the requirements for Star rank. Plan the next steps in your progress toward becoming an Eagle Scout.*

“Hitch Your Wagon to a Star.” That old admonition for getting on can be applied directly to Scouting. The next rank you can gain after First Class is that of Star Scout.

The advancement of Scouting, as you know, is designed to encourage you to master new skills, with a badge as your reward when you have completed the work. Some of these badges are the badges of Scout rank. Others—known as “merit badges”—give you a chance to try your hands at various crafts and hobbies, sports and occupational skills, and many other things. Certain numbers of these badges are required for the higher ranks in Scouting.

The whole next section of this book—from pages 355 to 377—is dedicated to showing you how to earn merit badges and how to meet the other requirements that will carry you forward and upward, through the ranks of Star Scout and Life Scout, the whole way up to Eagle. Study it carefully. Then plan your work and work your plan for reaching the top rank in Scouting.





ADVENTURE CAMPING

Summer camp is the biggest event in the whole Scouting year—there's something to look forward to!

But camping for a couple of weeks during the summer still leaves 50 weeks of the year to be accounted for. It's during those 50 weeks that you pick up most of your camping skills on any number of short camping trips of your troop and patrol. You learn camping on year-round trips—you practice it in summer camp.

Active patrols and troops aim for at least 10 nights of camping during the year in addition to summer camp. The success of those short camps depends on each fellow having a job to do—and doing it. There's work to it—but then, everybody works. And there's real joy to it, too—because when every member does his share of the work, everyone has time for his share of the fun.

The better you get at camping, the better you'll want your whole patrol to be—the more eagerly you'll help the new fellows who join the gang so that your whole outfit will get and keep a reputation for being the “campingest” patrol in the troop.

How can you be sure that yours is a good camping patrol?

You'll have a pretty fair idea about it when you camp with the troop. But the best way to find out is to take part in a district or council camporee and match yourself against other patrols.



Camporee Camping. In its simplest form a camporee is a demonstration of the outdoor skills of two or more patrols, or two or more troops, camping together one or more nights for fun and fellowship and for testing each other's camping skills.

Camporee camping boils down to honest-to-goodness patrol camping with a rating plan that'll show how well your patrol camps. The rating plan you'll be using may be developed by your local council or by your troop leaders, or may be the one your patrol leader has in his *Handbook for Patrol Leaders*.

How do you think the judges would rate your patrol at a camporee? To find out, put yourself in the judges' position and look at your patrol from their viewpoint.

You'd start checking your patrol the moment it arrives: How do the packs look? Are they properly packed? Is patrol equipment evenly distributed? Is the personal equipment adequate? Is each Scout correctly uniformed? Did the patrol bring its flag?

Next, for the camp making: Is the patrol organized for efficient camp making? Is a tenting crew busily at work putting up tents, preparing beds, making camp improvements? Is a cooking crew going full blast building a fireplace, getting water and wood, laying out pots and pans, starting to cook?

The camp is up at last. How does it look? Are the tents properly located, neat, with well-constructed beds? Is the kitchen satisfac-



Summer camping with your patrol and troop on the campsite of your local council is one of the best experiences you can have.

tory? Is food well handled? Is there a definite place for tools and are they kept there when not in use? What about garbage and dishwater disposal? Latrine?

And throughout the whole time of the camporee: Does each Scout have a definite duty? Does each boy carry through his responsibilities? Are meals ready on time and served family style? Is the patrol represented in all special events and contests? Is the Scout Law truly the law of the patrol's camp?

If your patrol is up to scratch on all these points, you'll know that it is good. But even more important: If all the patrols of the troop meet the test, you are in for a marvelous troop camp this summer.

Why? Because *a camporee is the perfect dress rehearsal for troop summer camp.*

At the camporee, everything is in shape campwise and everyone is trained for a 2- or 3-day camping event. All you have to do is to multiply by three or four and move the dates up into your summer vacation—and you're all set for the best troop summer camp ever!

Summer Camp With the Troop

The moment troop summer camp is announced in the spring, you'll be raring to go—you'll pitch in with your patrol to plan and work toward this wonderful event, aiming for a 100 percent turnout of the gang.

Troop camping is the Scout way of summer camping. And troop camping simply means that all the fellows in your troop



camp together with your own Scoutmaster and assistant Scoutmasters—usually on a site set aside for it in the local council camp, but occasionally on the troop's own campsite. Here each patrol lives as an individual unit within the troop area, with its own tents, its own kitchen, its own cooking, under the active leadership of its own patrol leader.

You wonder what troop summer camp will be like?

Well, to find out, imagine that you are already out there in camp—that you arrived the day before, that camp sprang up according to schedule, that everything has started to hum the way you trained for it on a number of overnight camps during spring.

A Day in Summer Camp. You awaken to an exciting new day with your best friends. You look out through the open tent door and see a smiling sun in a blue sky—then jump out of bed, grab soap and towel, and join the others for the morning wash. A few moments later you are back in your tent, straightening up things, getting blankets out for airing, putting on your uniform.

The cook sounds off: "Come and get it!" Not a moment too soon! What a breakfast! But then, it has to be hearty to carry you through the excitement that's ahead.

After breakfast there's work to be done. The camp must be made spick-and-span in a hurry—which it is, just in time, too, for the troop leaders are already coming around the bend for the morning checkup. Your patrol gets the honor flag of the day. You knew it would all the time.

You and the rest of the troop gather around the flagpole where Old Glory goes aloft to wave over the activities of your camping day. Your eyes follow the flag—red, white, blue, against a clear summer sky!

After the flag ceremony, you are ready for the day's adventure.

4. **LIFEGUARDS**—Two older Scouts who are good swimmers are stationed ashore as lifeguards, equipped with lifeline.

5. **LOOKOUT**—A lookout stands at a point from which he can watch all swimmers.

6. **ABILITY GROUPS**—The Scouts are divided into three groups: Nonswimmers who are just learning; beginners who have swum 50 feet; swimmers who have made 100 yards, 25 of them on the back, and who can float. Each group stays in its area during the swim.

7. **BUDDY PLAN**—Each Scout is paired with another boy of the same swimming ability. Buddies check in together, keep within 10 feet of each other at all times, and check out together. Whenever a buddy signal is sounded during the swim, buddies grasp each other by the hand and hold their arms high, so that the lookout can check the number of buddy teams.

8. **GOOD DISCIPLINE**—The person in charge of the waterfront sees to it that there is good discipline—with strict attention to the rules, but with a chance for everyone to have a good time.

Lifesaving. It is wonderful to know that you are safe when swimming—but it is even more wonderful when you know that you are able to save someone else who would otherwise drown.

This year, in the United States, more than 6,000 people, mostly boys and men, will drown while swimming or playing in the water—some of them by accident, many as a result of taking foolish chances. You may have the chance to help cut down this number by learning proper lifesaving methods in camp.

Most water accidents happen close to shore or dock. You may be able to **REACH** the victim with a helping hand, a pole, or a branch. If the victim is out too far for that, look for something to **THROW** to him. A properly equipped waterfront will have a



ring buoy prominently displayed, ready for immediate use.

Too far to reach with a rope? Then get into a boat and **ROW** out to the victim, or paddle to him in a canoe.

SWIMMING RESCUE — No equipment around? Then and only then do you **GO**! Strip down quickly to undershorts while keeping an eye on the victim the whole time. Take your shirt between your teeth at the back of the collar. From a level shore, run into the water; from a dock, jump in, feetfirst, in a high, wide open jump, getting out as far as possible. Strike out for the drowning person. When near, grasp the shirt collar in one hand, flip the shirttail into the victim's hands, and tow him ashore.

If there is nothing around that you can carry out with you, swim to the victim's back. Slide one hand across his shoulder and chest and under his opposite arm. Swim to shore with your free arm and with a scissors kick of your legs.

In approaching a drowning person be careful that he does not grab hold of you. That's the reason for using a shirt or for reaching him from the back. If you train yourself in approaching properly, you should have no trouble. If in spite of your precautions a person gets hold of you, take a deep breath and submerge. He will let go!

341

GO to his help by swimming—but only when no other method can be used.



REACH him with a stick.

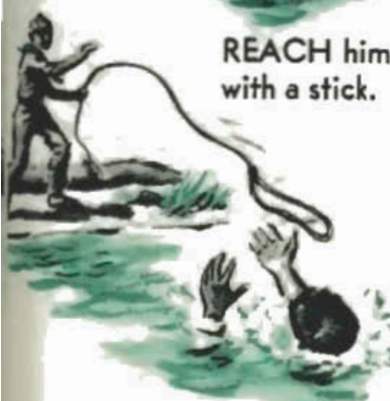

THROW a rope end to him.



ROW to him in a boat.



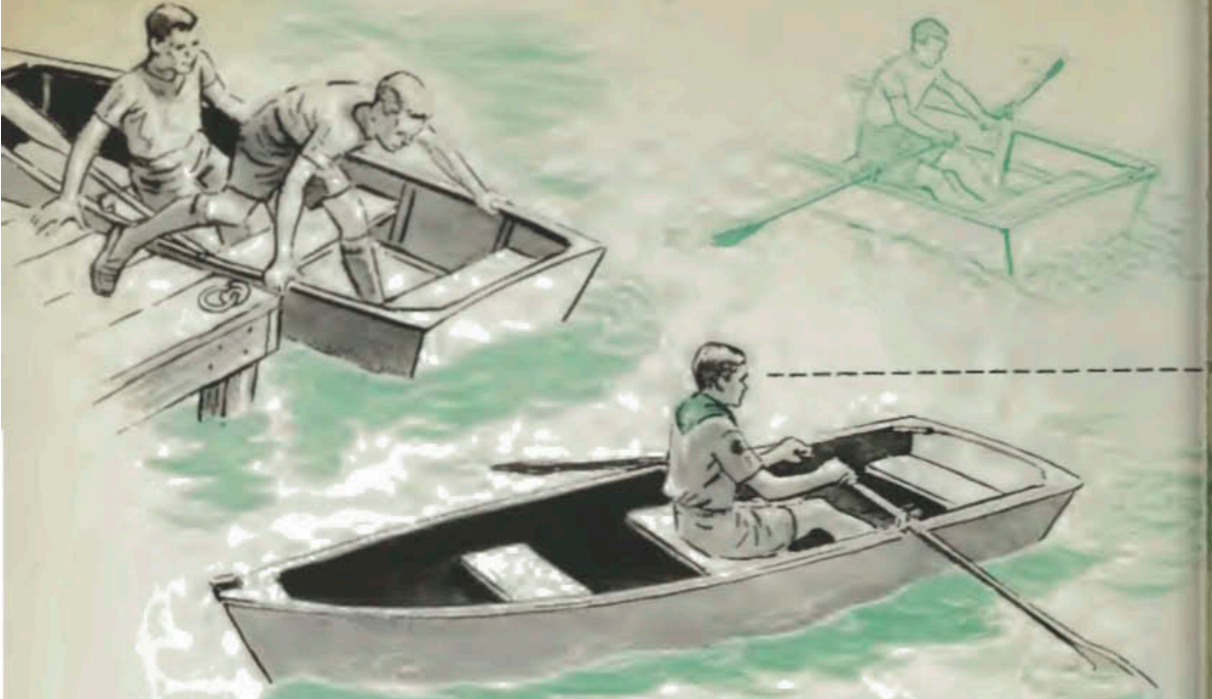

To row a straight course, keep a landmark over the center of stern.

Rowing. In camp you'll probably be singing the old song, "Row, row, row your boat gently down the stream . . ." If you're lucky you'll be doing it, too.

When you get into a boat step well into the middle of it, grasping the gunwales for balance, and immediately take your place on the proper seat so that the boat is correctly trimmed—that is, with your weight the proper distance from bow (front) and stern (back). Bow should be about 3 inches higher than stern.

Brace your feet against the stretcher, the crosspiece on the bottom of the boat. Place the oars in the oarlocks and adjust them. The handle ends should come close together, directly in front of the center line of your body.

ROWING STROKE—There are four parts to the complete rowing stroke: the *catch* in which you bend your body toward the stern, raise oar handles a little, and drop the blades edgewise into the water; the *pull* in which you swing your body backward, arms straight, then bend arms and pull, bringing elbows tightly into the ribs; the "feather" in which you turn your knuckles up, enough to make the oar blade turn flat with the water's surface; and the *recovery* in which you move the oar blades into position for the next stroke by swinging your body toward the stern and turning



Learn to "feather" your oars.

If you should ever be in a boat that gets swamped, stick to the boat—it will stay afloat until help arrives.

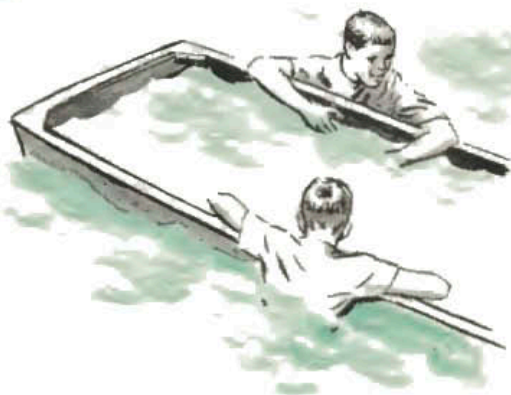

your hands, ready for the next *catch* position. The right way to make the stroke will come to you after practice.

ROWING A STRAIGHT COURSE—To row a straight course, point the bow of your boat directly toward your destination. Looking over the center of the stern, pick out a landmark on shore—a rock or a tree. Then, as you row, try to keep that mark always over the center of the stern.

You'll have to look over your shoulder from time to time to be sure that you have not been carried sideways by wind or current. If you are off your course, pull harder on one oar than on the other to get yourself back. Land by running the bow up on shore while you "ship" your oars.

"DON'T GIVE UP THE SHIP"—If you should ever be in a boat that capsizes or gets swamped with water, stick to the boat. It will float and will easily carry you until someone sees you and comes to the rescue. The worst thing you can do is abandon ship and swim for the shore.

If there are several people involved and they can't all get inside the boat, have half of them hold on to one side, the other half to the other. A swamped 12-foot rowboat has been known to keep 20 people afloat until help arrived.



Best paddling position is the kneeling position. Or kneel on one knee and brace yourself with other leg in front of you.



Canoeing. The canoe was handed down to us from the American Indian. You can just see him paddling along, noiselessly, down the river, in his birchbark canoe! It is a proud sight! And canoeing is a proud sport!

The modern canoe is based on the red man's design. In using it you keep alive an early American tradition.

The canoe used in camps today is made of wood, aluminum, or fiber glass. Give it good care. In handling it on shore always carry it—never drag it over rough ground. For launching, balance it by carrying it amidships, one person on either side, then lower bow into water and ease it forward until it is afloat. The bowman gets in first, and, holding the sides, proceeds to his position, stepping exactly in the center of the canoe and holding on to the gunwales as he goes. The sternman follows, giving the canoe a shove into deep water as he takes his place.

PADDLING—The proper paddling position is a kneeling posture, with the knees well apart on a light kneeling pad, the buttocks resting against a thwart (crosspiece). If your canoe has seats, take them out. From the very beginning get into the habit of using the



Bow stroke is common stroke used by bowman.



kneeling position. It is the safest, because it keeps your center of gravity low. It is also best for speed and for keeping the canoe steady and under control.

When there are two in a canoe, the bowman ordinarily uses a straight *bow stroke*, dipping about two-thirds of the blade in the water and drawing the blade straight aft, while the sternman paddles on the opposite side of the canoe and finishes his stroke with a hook (the *J-stroke*) that serves to steer the canoe. When paddling a canoe alone, you have to be both bowman and sternman. Then it is a matter of knowing both the straight stroke and the stroke with the hook as you paddle in a kneeling position almost in the middle of the canoe.

Practice does it. Then, when you have become an expert canoeist and camper, the day may arrive when you'll set out with a few fellows on a wilderness canoeing expedition—paddling along over quiet lakes . . . swooping down into white water . . . carrying your canoe (portaging) around bad rapids or falls . . . landing at night to make camp . . . starting out again the next morning for more exciting adventure.

Campfires

CAMPFIRE! There's nothing in the world that can compare with sitting with your best friends in a close circle, under the spell of the fire, watching the flickering flames, having a wonderful time together.

The Campfires of Troop and Council. The campfires of the large groups are the spectacular ones.

As dusk falls, the campers gather in the special campfire circle. The leader steps forward and, as the flames soar upward, he opens the fire with an impressive ceremony.

Then follows a program of songs, serious and funny in the right proportion—all of them good, none of them cheap. There are stunts and skits.

Fellows with special abilities—singing, storytelling, or otherwise—do their stuff.

There may be a few campfire games, such as Indian hand wrestling, leg wrestling, dogfight. Perhaps a tall-story contest will be held with fellows of the gang trying to outdo Paul Bunyan and John Henry.

Then, finally, the good-night song and your camp's traditional, impressive closing ceremony.

Your Patrol Campfires. The smaller campfires of your patrol are different. Around them friendship and patrol spirit grow stronger.

As the fire is lit, you talk of the day that has gone and the tomorrow that is to come. You discuss the plans for the rest of the camp. And then, very possibly, you drift into talking about the troop, of Scouting, of something else that's on your mind.

"Let's have a song!" finishes the discussion and starts a new mood. Another song. A story by your patrol leader. Then, after one of those silent pauses where you just sit and watch the flickering flames, someone turns to John: "What about the song you sang at the troop show last winter?" And there goes John—followed by Bill and Jack. More discussion, maybe a stunt, another song.



While the fire is leaping high, your singing will be as gay as the dancing flames. But as the fire burns low, your songs turn into the soft, melodious kind.

The evening has gone miraculously by. It is time for bed. You stand up, facing the fire. You lift your arms over the dying flames, then lower them while you all sing taps, softly:

Day is done. Gone the sun

From the lake, from the hills, from the sky.

All is well. Safely rest. God is nigh.

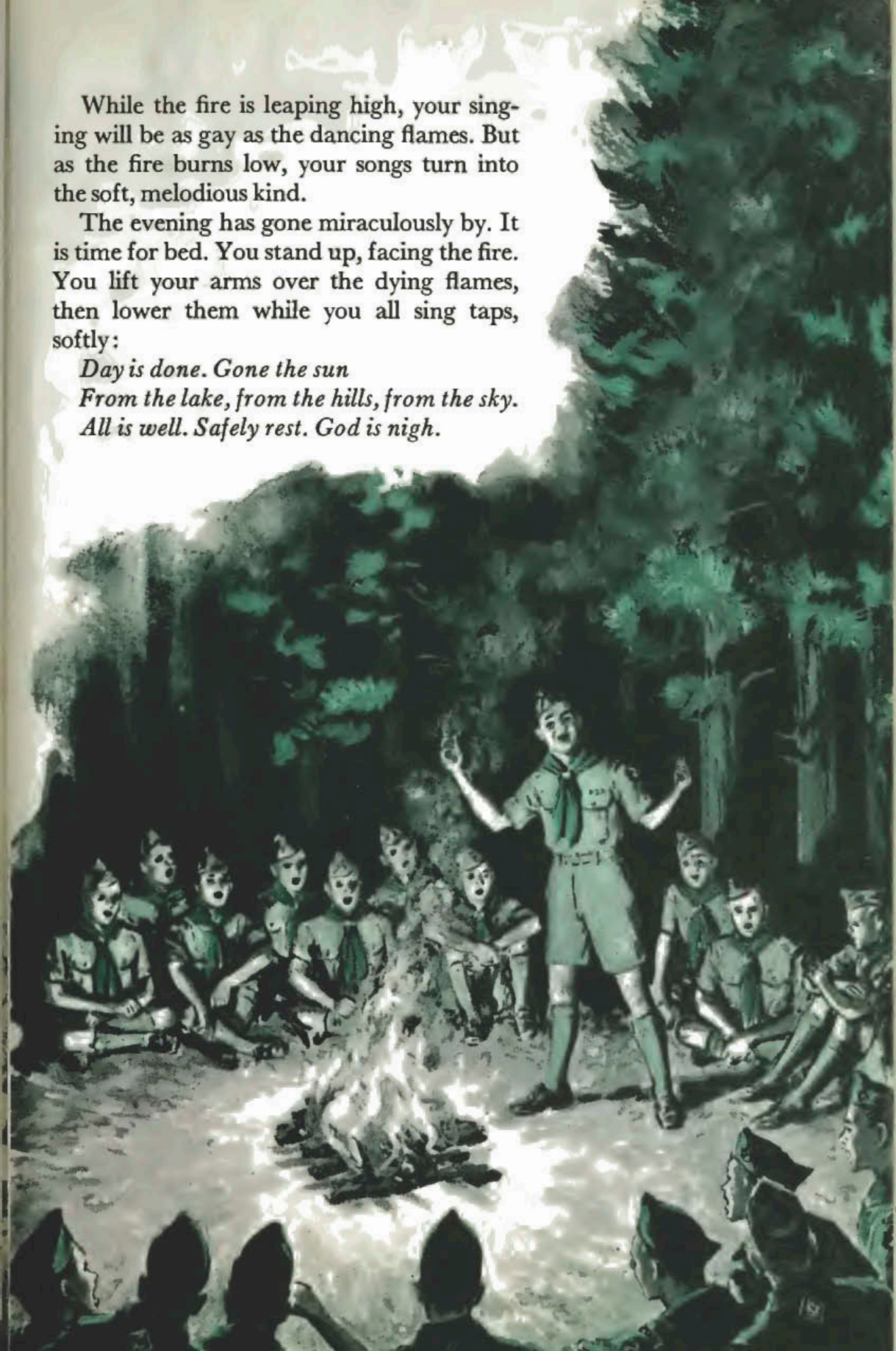



Try Indian camping sometime—but not before you are a good camper.

Primitive Camping

When you have mastered the art of regular camping in patrol and troop, you'll have the necessary skills to go in for the more primitive kind and to enjoy it to the full, making use of all your ingenuity.

Indian Camping. You may like to try Indian camping, for example. For this you take very little equipment. If teepees are available, fine. If not, use your regular tents or build wigwams, by covering frameworks of branches with tarps.

Clothing is an easy matter when you are Indian camping. Moccasins and loincloth are your daylong wear. Your moccasins may be regular Scout moccasins, or homemade from a moccasin kit. The loincloth is best made of outing flannel—red or blue, with a bias binding in a contrasting color, if you like. The cloth should be as long as you are tall, one-third your waist-measure wide.

You will have lots of things to occupy your time in Indian camp—putting up all the gadgets the Indians used, playing Indian games, cooking Indian meals over fires lit by fire by friction as shown on page 349, taking part in campfires that feature Indian songs, dances, and ceremonies.

FIRE BY FRICTION



Spindle is 1 foot long, about $\frac{3}{4}$ inch thick. Cut it octagonal. Round one end, taper the other.



Fireboard is about 4 inches wide, $\frac{1}{2}$ inch thick, 1 foot long. Gouge hollow for spindle. Cut V-shaped cut almost to center of spindle hollow.



Bow is stiff branch, $2\frac{1}{2}$ feet long, with strong leather thong.

Hand piece is chunk of wood with hole to fit spindle top.



Tinder may be shredded cedar bark, fine wood shavings, mouse nest.

Good woods for fire by friction: yucca, basswood, elm, willow, white cedar, aspen, cottonwood.



Place fireboard with notch on tinder. Kneel down, foot on fireboard. Put bowstring around the spindle. Hold spindle upright with hand piece. Rest hand with hand piece against knee. Set spindle spinning with long strokes with increasing pressure. Keep going until heavy smoke rises. Knock ember formed in notch into tinder, blow into flame with steady blow.



Pioneer Camping. In pioneer camping your patrol becomes a gang of old-time pioneers on the backwoods trail, putting up covered-wagon-type shelters or simple lean-tos and going in for real pioneering—making trapper's beds, lashing together tables and benches, cooking your food in Dutch ovens, barbecuing your meats over fires made by flint and steel, building a bridge over a nearby river, constructing a raft for fun on the lake.

FIRE BY FLINT AND STEEL

Fire-by-flint-and-steel set consists of piece of flint, old file, punk, tinder. "Punk" is prepared flammable material for catching the spark struck from the steel. Lamp wicking and charred cloth make good punk. (To prepare lamp wicking, roll up a short piece lengthwise; tie it into a tight cylinder by winding string around it; char one end by lighting it and then snuffing out the glowing ember. To char a strip of cotton cloth, put a stick through one end of it and hold it over a coffee can; light lower end; as flame moves up, lower glowing end of cloth into can; when flame goes out put lid on can and let tinder cool.) To make fire, hold flint and wicking between fingers. With steel, strike glancing blow against flint aimed in such a way that sparks fly into wicking. Place the smoldering wicking in tinder and blow it into flame with long, soft blows. Or place charred cloth on tinder on ground, aim sparks into it. Lift up tinder with smoldering cloth and blow it into flame.



Desert-Island Camping. Desert-island camping is something else again. Here you can take all the equipment you want (remember the boxes of stuff that Robinson Crusoe got off the stranded ship?), but you must live "off the land," as far as possible, using greens and roots, fruits and nuts, and the fish you can catch, for part of your diet. You need plenty of survival training for this kind of camping.

Winter Camping. Winter camping up north when deep snow covers the ground is a special kind of primitive camping that brings out the real HE-MAN in you. Here your main considerations are keeping warm and dry, and sleeping warm and dry.

KEEPING WARM means the right kind of vigorous activities, the right kind of grub with extra heat-producing fats and sugars, and the right kind of clothing. Your clothes should be woolen, loosely fitting garments, with a windproof jacket over them. Your feet need special warmth—so on with a pair of heavy woolen socks over your regular stockings and into greased boots, ski boots, or snow-pacs large enough to allow for the extra socks. Ski cap and mittens—and you're all set.

SLEEPING WARM means proper tenting and bedding. An open-front tent such as a Baker or an Explorer is especially good for winter camping—you can have a large fire burning in front of it. Pick out a spot sheltered from the wind, scrape the snow away, and put up the tent. Then make a bed—from boughs, if available, with a heavy layer of newspapers on top of them—it's hard to beat newspapers for insulation. Next, your ground cloth and your wool blankets or sleeping bag. Gather a large supply of firewood and arrange for shifts to keep a fire going all night.

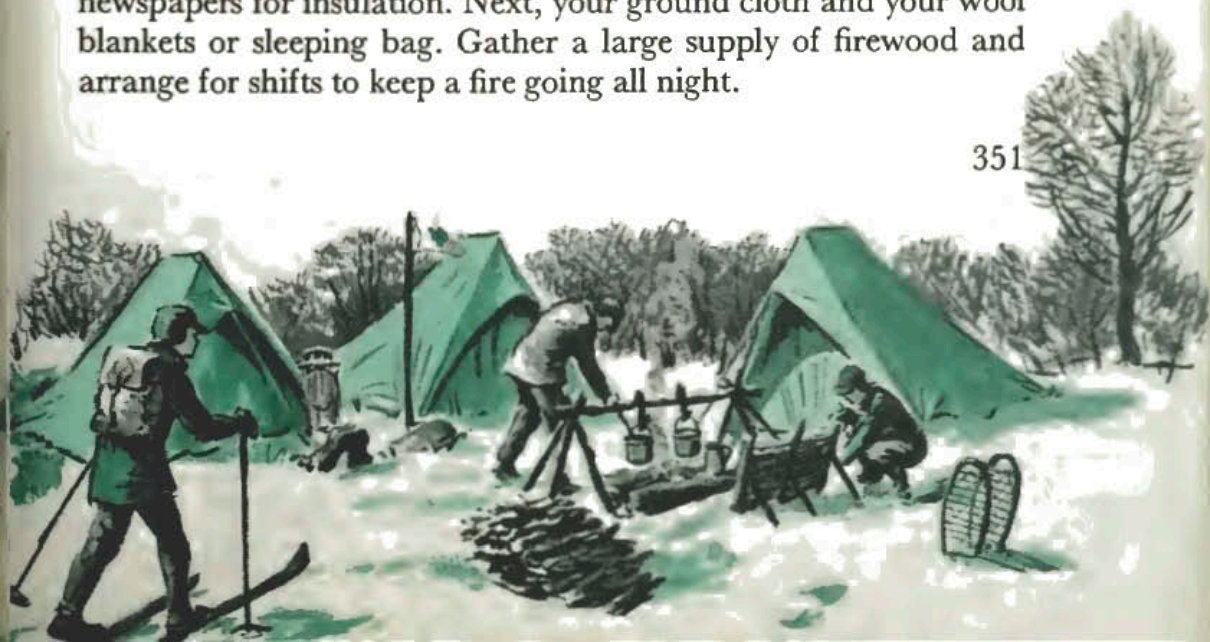



TRAVELING CAMPS

Traveling camps are for experienced campers only. In those, you cover a lot of territory. You need strong leadership and carefully laid plans.

There are plenty of places to go: national parks, historic spots, wilderness trails, canoe waterways. Besides, there is Philmont—and there are jamboree adventures awaiting you.

The main requirement for you to participate in such an outstanding experience is a deep desire on your part to go. It will take effort to earn the necessary funds—but first of all, it takes the right Scout spirit and the largest amount of Scoutcraft knowledge.

Philmont. Some day when you are 14 years of age and have shown real Scout spirit and camping ability, you may have a chance to take part in an unforgettable Philmont expedition—taking on challenging tasks, tackling man-sized obstacles, solving man-sized problems.

Philmont is the national camping area for older Boy Scouts and Explorers. It is located near Cimarron, New Mexico, and comprises 137,000 acres of rugged western country on the slopes of the Sangre de Cristo range of the great Rocky Mountains. Every





year, thousands of Scouts trek across the country to Philmont. For 12 days or longer they disappear into the wilderness—traveling on foot or on horseback, spending a night perhaps at a trail camp, another up a canyon or on a mountaintop.

When you check out after that kind of experience, you'll know that you've had a man's adventure.

Jamborees. The climax of your Scout camping and the most inspiring event in your Scouting life will come the day you travel cross-country to participate in a national jamboree of Scouts from every corner of America with guests from many other countries, or go overseas for a world jamboree of Scout delegates from all around the globe.

World jamborees are normally held every 4 years, national jamborees during the intervals between the world events. As many as 50,000 Scouts have taken part in some of these tremendous brotherhood gatherings.

Through these get-togethers of boys from around the world, the Scout movement is doing its part, in Baden-Powell's words, "to establish friendships among Scouts of all nations and to help to develop peace and happiness in the world and goodwill among men."





TRAVELING CAMPS

Traveling camps are for experienced campers only. In those, you cover a lot of territory. You need strong leadership and carefully laid plans.

There are plenty of places to go: national parks, historic spots, wilderness trails, canoe waterways. Besides, there is Philmont—and there are jamboree adventures awaiting you.

The main requirement for you to participate in such an outstanding experience is a deep desire on your part to go. It will take effort to earn the necessary funds—but first of all, it takes the right Scout spirit and the largest amount of Scoutcraft knowledge.

Philmont. Some day when you are 14 years of age and have shown real Scout spirit and camping ability, you may have a chance to take part in an unforgettable Philmont expedition—taking on challenging tasks, tackling man-sized obstacles, solving man-sized problems.

Philmont is the national camping area for older Boy Scouts and Explorers. It is located near Cimarron, New Mexico, and comprises 137,000 acres of rugged western country on the slopes of the Sangre de Cristo range of the great Rocky Mountains. Every





year, thousands of Scouts trek across the country to Philmont. For 12 days or longer they disappear into the wilderness—traveling on foot or on horseback, spending a night perhaps at a trail camp, another up a canyon or on a mountaintop.

When you check out after that kind of experience, you'll know that you've had a man's adventure.

Jamborees. The climax of your Scout camping and the most inspiring event in your Scouting life will come the day you travel cross-country to participate in a national jamboree of Scouts from every corner of America with guests from many other countries, or go overseas for a world jamboree of Scout delegates from all around the globe.

World jamborees are normally held every 4 years, national jamborees during the intervals between the world events. As many as 50,000 Scouts have taken part in some of these tremendous brotherhood gatherings.

Through these get-togethers of boys from around the world, the Scout movement is doing its part, in Baden-Powell's words, "to establish friendships among Scouts of all nations and to help to develop peace and happiness in the world and goodwill among men."



ON THE ADVANCEMENT
TRAIL TO
EAGLE

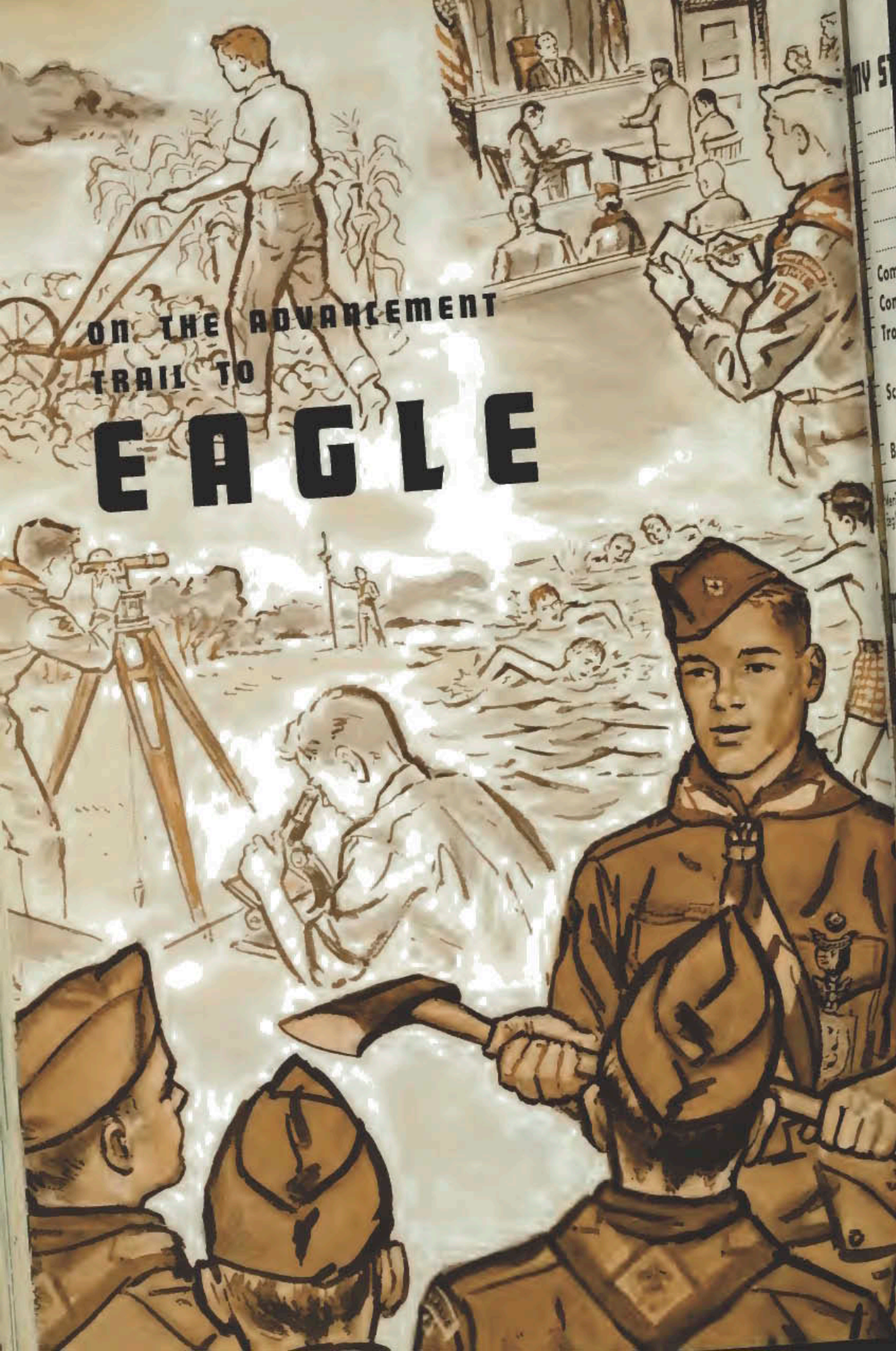

MY STAR SCORE

<input type="checkbox"/> Merit Badge	/	19.....
<input type="checkbox"/> Merit Badge	/	19.....
<input type="checkbox"/> Merit Badge	/	19.....
<input type="checkbox"/> Merit Badge	/	19.....
<input type="checkbox"/> Merit Badge*	/	19.....
<input type="checkbox"/>	Community Service	/	19.....
<input type="checkbox"/>	Conservation	/	19.....
<input type="checkbox"/>	Troop Officer or Service	/	19.....
<input type="checkbox"/>	Scoutmaster Conference	/	19.....
<input type="checkbox"/>	Board of Review	/	19.....

Merit badge from the required Eagle Scout list.

MY LIFE SCORE

<input type="checkbox"/> Merit Badge	/	19.....
<input type="checkbox"/> Merit Badge	/	19.....
<input type="checkbox"/> Merit Badge	/	19.....
<input type="checkbox"/> Merit Badge	/	19.....
<input type="checkbox"/> Merit Badge	/	19.....
<input type="checkbox"/> Merit Badge*	/	19.....
<input type="checkbox"/> Merit Badge*	/	19.....
<input type="checkbox"/> Merit Badge*	/	19.....
<input type="checkbox"/> Merit Badge*	/	19.....
<input type="checkbox"/> Merit Badge*	/	19.....
<input type="checkbox"/>	Community Service	/	19.....
<input type="checkbox"/>	Conservation	/	19.....
<input type="checkbox"/>	Troop Officer or Service	/	19.....
<input type="checkbox"/>	Scoutmaster Conference	/	19.....
<input type="checkbox"/>	Board of Review	/	19.....

Merit badge from the required Eagle Scout list.

MY EAGLE SCORE

<input type="checkbox"/> Merit Badge	/	19.....
<input type="checkbox"/> Merit Badge	/	19.....
<input type="checkbox"/> Merit Badge	/	19.....
<input type="checkbox"/> Merit Badge	/	19.....
<input type="checkbox"/> Merit Badge	/	19.....
<input type="checkbox"/> Merit Badge	/	19.....
<input type="checkbox"/> Merit Badge	/	19.....
<input type="checkbox"/> Merit Badge	/	19.....
<input type="checkbox"/> Merit Badge	/	19.....
<input type="checkbox"/> Merit Badge	/	19.....
<input type="checkbox"/> Merit Badge	/	19.....
<input type="checkbox"/>	Camping MB	/	19.....
<input type="checkbox"/>	Cooking MB	/	19.....
<input type="checkbox"/>	Citizenship in the Com- munity MB	/	19.....
<input type="checkbox"/>	Citizenship in the Nation MB	/	19.....
<input type="checkbox"/>	Nature MB	/	19.....
<input type="checkbox"/>	Soil and Water Con- servation MB	/	19.....
<input type="checkbox"/>	Personal Fitness MB	/	19.....
<input type="checkbox"/>	First Aid MB	/	19.....
<input type="checkbox"/>	Swimming MB	/	19.....
<input type="checkbox"/>	Lifesaving MB	/	19.....
<input type="checkbox"/>	Safety MB	/	19.....
<input type="checkbox"/>	Troop Officer for 6 Months	/	19.....
<input type="checkbox"/>	Community Service	/	19.....
<input type="checkbox"/>	Scoutmaster Conference	/	19.....
<input type="checkbox"/>	Board of Review	/	19.....



how to become an **EAGLE SCOUT**

Your Scout life in the outdoors has helped make your body strong and healthy. Your mind has become trained to make deductions from what you see and hear. You have grown self-reliant and resourceful. And while taking part in the activities of your patrol and troop you have reached your first Scouting goal: You are a First Class Scout.

Your First Class badge shows that you have successfully followed the broad trail of Scouting. But the road goes much farther and, as a real Scout, you want to follow the trail to the end. There are more badges to be earned, more ranks to be reached—until finally, if you have the energy and ability, you succeed in reaching the top in Scout advancement and become an Eagle Scout.

Did you notice that little word “if”? In that word lies the secret to your Scout advancement.

In Scout advancement each boy proceeds at his own speed. Your rate of advancement depends entirely on you. In Scout advancement you are not trying to get ahead of anyone else—you try to better your own previous record. You move as far and as fast as your ambition carries you.

Your first steps in Scout advancement brought you through the basic Scout ranks of Second Class and First Class.

Your next step is to set out to earn merit badges in special fields that interest you as well as the specific merit badges required for the ranks of Star, Life, and Eagle Scout. The earlier in your Scouting career you earn these required badges, the more certain you are of reaching Eagle.

And all along the way, you have to demonstrate your Scout teamwork, Scout spirit, and leadership ability.

MERIT BADGES

Your advancement through Second and First Class ranks was a natural outgrowth of your patrol and troop experiences. In merit badge advancement you are on your own.

Why do we have merit badges in Scouting? For two main reasons: to encourage you to increase your skill in things you like to do and to give you a chance to try out new activities that may result in new interests.

Do you want to become an expert camper? The Camping and other outdoor merit badges will help you. Do you like swimming? The Swimming and Lifesaving merit badges may start you on the way to being a champion. If you live in the country, the projects in the farming merit badges will aid you in becoming a first-rate farmer. Collecting rocks and minerals on a patrol hike for the Geology merit badge may start you on a hobby that will continue all your life. If you like to make things, the merit badges in Electricity, Machinery, and Sculpture may open up fields that are brand-new to you.

Many men who were once Scouts feel that their entire lives were influenced by their merit badge work. Dr. Paul Siple, who as a Scout went with Admiral Richard E. Byrd on his expedition to the South Pole, first became interested in science through his merit badges. He is now one of the nation's leading scientific explorers and was himself the leader of an expedition to the South Pole. Hundreds of doctors, engineers, forest rangers, and naturalists had their ambitions kindled while earning merit badges as Scouts. You, too, may start on your lifework by working on a merit badge.

Look over the list of merit badge subjects on page 359 and the description of related merit badges on pages 370-77. In these groups related merit badges are placed together to suggest

to you how you can go exploring in a broad interest field.

Decide on the badges you would like to earn. Then secure a copy of the pamphlet *Boy Scout Requirements*. This contains the up-to-date requirements for all merit badges. Your patrol probably has one of these pamphlets in the patrol library, or the troop in the troop library. If not, you can get it at your council office, or from the Scout distributor.

Preparing for Merit Badges. When you have made up your mind that you want to earn a certain merit badge, speak to your Scoutmaster about it and get his advice. He will give you a merit badge application signed by himself and put you in touch with the merit badge counselor on the subject you have chosen.

Merit badge counselors are among the finest men of the community. They are men who are successful in their respective fields and interests. They are men who believe in Scouting enough to give valuable time to help Scouts advance.

You make an appointment with the merit badge counselor and go to see him. You talk over the subject with him. He will tell you what is required of you and how and where you can get the information you need. He may suggest several books and he will certainly expect you to secure and study the merit badge pamphlet on your subject. A pamphlet covering each merit badge is published by the Boy Scouts of America. All these pamphlets are available at 35 cents each through your council office and local Scout distributor. Your public library may have the whole set.

After this first interview with your merit badge counselor, you go to work doing the things the requirements call for.

Study the merit badge pamphlet that covers your subject.

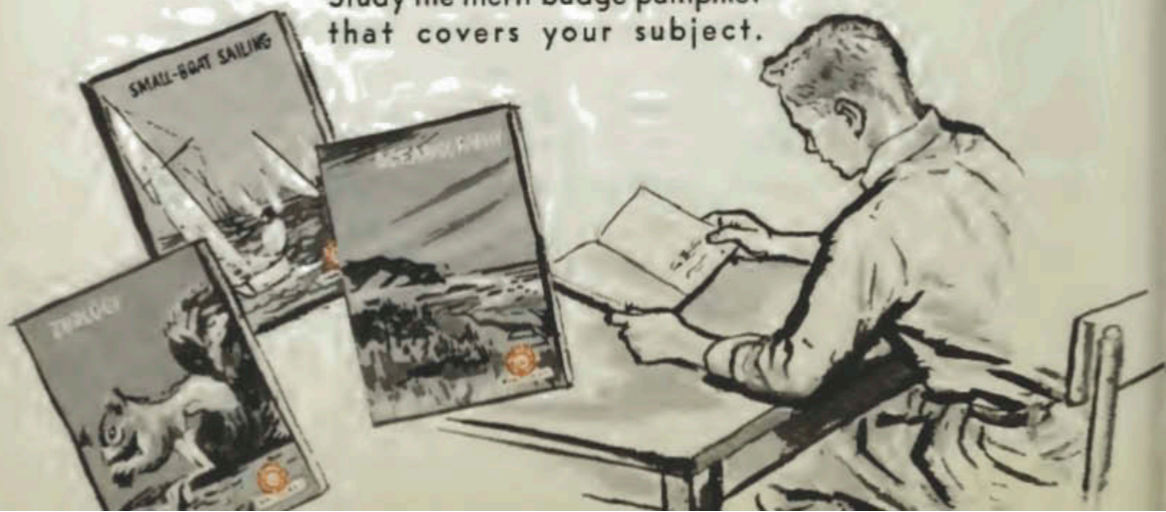

MERIT BADGES

Agriculture*	Farm Arrangement*	Photography
Animal Industry*	Farm Mechanics*	Pigeon Raising*
Archery	Farm Records*	Pioneering
Architecture	Fingerprinting	Plumbing
Art	Firemanship	Pottery
Astronomy	First Aid	Poultry Keeping*
Athletics	First Aid to Animals*	Printing
Atomic Energy	Fishing	Public Health
Automotive Safety	Forage Crops*	Public Speaking
Aviation	Forestry*	Rabbit Raising*
Basketry	Fruit and Nut Growing*	Radio
Beef Production*	Gardening*	Railroading
Beekeeping*	Geology	Reading
Bird Study	Hiking	Reptile Study
Bookbinding	Hog Production*	Rowing
Botany	Home Repairs	Safety
Bugling	Horsemanship	Salesmanship
Business	Indian Lore	Scholarship
Camping	Insect Life	Sculpture
Canoeing	Journalism	Sheep Farming*
Chemistry	Landscaping	Signaling
Citizenship in the Community	Leatherwork	Skiing
Citizenship in the Home	Lifesaving	Small-Boat Sailing
Citizenship in the Nation	Machinery	Small Grains*
Coin Collecting	Marksmanship	Soil and Water Conservation*
Communications	Masonry	Space Exploration
Conservation of Natural Resources*	Metallurgy	Stamp Collecting
Cooking	Metalwork	Surveying
Corn Farming*	Model Design and Building	Swimming
Cotton Farming*	Motorboating	Textiles
Cycling	Music	Weather
Dairying*	Nature	Wildlife Management*
Dog Care	Oceanography	Wood Carving
Drafting	Painting	Woodwork
Dramatics	Personal Finances	World Brotherhood
Electricity	Personal Fitness	Zoology
Electronics	Pets	

*These merit badges may be earned by completing the 4-H Club or FFA projects in the subject.

Meeting the Merit Badge Requirements. When you have trained yourself in the skills and have prepared the things your chosen merit badge requires and feel yourself ready, you get in touch with the merit badge counselor again. This time take with you all the materials, statements, articles required, as well as the application properly filled out.

Most of the merit badges contain requirements for demonstrating your ability to perform certain tasks, ranging from pitching a tent for the Camping merit badge to swimming 150 yards for the Swimming merit badge.

Your merit badge counselor may want you to demonstrate these skills before him, or he may have made arrangements for you to have them certified by others.

When you have met all the requirements to the merit badge counselor's satisfaction, he signs your application to show that you are entitled to the award—that you have actually merited the merit badge.

Receiving the Merit Badge. As soon as the merit badge counselor has approved the application, you turn the blank over to your Scoutmaster. He registers your accomplishment with the local council office and secures the embroidered merit badge.

Shortly afterward, at a troop meeting or at a special event where your parents may be present, your Scoutmaster presents the merit badge to you. There will be pride in his voice when he gives you the badge you have earned—and there will be pride in your heart as you receive it from your leader's hand.

You have reached an important goal—and having reached it, you immediately set yourself another.

There are many future goals ahead of you, many skills to be mastered—many badges to be earned before the Eagle Scout badge is pinned on your uniform.

Wearing the Merit Badge Sash. Most Scouts wear their merit badges on a merit badge sash which is worn over the right shoulder. The merit badges are sewn three across starting from the top as illustrated on page 361. Wear your merit badge sash at courts of honor, troop inspections, flag ceremonies, and when you are on special service projects.

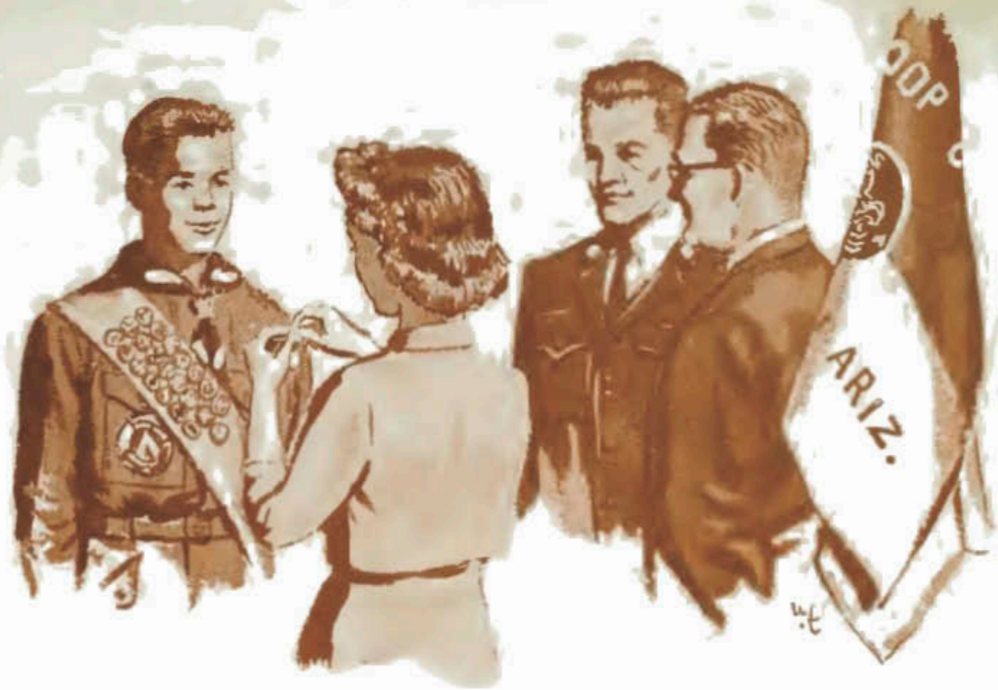

You'll receive your badge at your troop's court of honor.

Scouts may wear up to six badges on the right sleeve of the long-sleeved shirt, in rows of two, the bottom row parallel to the cuff and 3 inches from the end of the sleeve. If the sash is worn, merit badges may not appear on the sleeve.

STAR, LIFE, AND EAGLE SCOUT ADVANCEMENT

One of your big incentives for merit badge advancement is that earning certain merit badges makes you eligible for advancement to Star and Life Scout and, eventually, to the rank a Scout desires most—Eagle Scout.

But those ranks are not gained through merit badges alone. As in all other Scout advancement, the skills you learn are only part of the picture. Merit badges in Scoutcraft and other interests count only for part of the requirements. The other requirements call for service projects, for work in conservation, for leadership, and for evidence of your Scout spirit.

What To Do To Reach Higher Ranks. The most important thing you have to do to reach the higher ranks in Scouting is to make up your mind to do it. It is always easy to drift along with the crowd and say to yourself "I'll get ahead—one of these days."

But that is not the way to make the most out of your life—and certainly not the way to advance in Scouting.

There is no easy road to Star, Life, and Eagle. The higher the rank the tougher the going, the firmer the self-discipline you have to exercise. It takes time and effort and sacrifice to reach the top. But when you get there—boy! what a view of the opportunities that lie ahead of you in life!

MERIT BADGES—As a First Class Scout you are well on your way toward becoming a good outdoorsman and camper. The smartest way to earn the five merit badges for Star is therefore to try for a couple of badges related to the outdoors, and to add to those a couple dealing with your special hobbies or interests and one of the badges specifically required for Eagle.

When you set out to earn the 10 badges required for Life, keep in mind that 5 of these must be among the badges required for Eagle. The others may be in any subjects you like.

For Eagle, 21 merit badges are required. Their selection is even more precisely defined than for Life: 11 specific badges in outdoor, fitness, and service fields—Camping, Citizenship in the Community, Citizenship in the Nation, Cooking, Nature, Soil and Water Conservation, Personal Fitness, First Aid, Swimming, Life-saving, and Safety—and 10 of your own choice.

All of the merit badges you have a chance to earn are shown in full color on pages 370-76.

SERVICE AND LEADERSHIP—To become a First Class Scout you were expected to show **FIRST CLASS** participation in the activities and service projects of your patrol and your troop. Your performance for the higher ranks should be even better.

For Star and for Life your participation, in addition to your active and dependable attendance at all activities, will involve leadership or special work in the troop. You are also required to perform two service projects—one that will benefit your church or synagogue, school, or community, another in the field of conservation.

For Eagle rank the leadership requirement is even more demanding: It calls for the performance of the duties of a troop warrant officer for a period of not less than 6 months. Another service requirement calls for a project to be planned, developed, and carried out by yourself.

STAR SCOUT REQUIREMENTS



To become a Star Scout, you must show by your attendance record that you have been active and dependable in troop meetings and activities for at least 3 months since becoming a First Class Scout and do the following:

Service shall be figured from the date of the board of review to the same date 3 months later. For example, the date of the First Class board of review was January 10. The boy would be eligible for Star review on April 10.

1. Earn five merit badges, including at least one of those required to become an Eagle Scout (Camping, Citizenship in the Community, Citizenship in the Nation, Cooking, Nature, Soil and Water Conservation, Personal Fitness, First Aid, Swimming, Lifesaving, and Safety).
2. While a First Class Scout, take part in at least one service project helpful to your church or synagogue, school or community.
3. While a First Class Scout, take part in a conservation project or make a field trip to learn more about conservation.

This is another project in addition to that carried out in Requirement 2.

4. While a First Class Scout, serve actively as a troop warrant officer (patrol leader, senior patrol leader, assistant senior patrol leader, junior assistant Scoutmaster, instructor, scribe, quartermaster, librarian, den chief) or carry out a Scoutmaster-assigned project to help the troop.
5. After completing the above requirements, meet with your Scoutmaster in a personal conference to discuss your ideas about the meaning of the Scout Oath (or Promise), the Law, motto, and slogan. Give examples to show that you do your best to live up to these ideals in your daily activities. Look over the requirements for Life and discuss your progress toward becoming an Eagle Scout.



The board of review for higher ranks consists of men who are prominent in your community.

SCOUT IDEALS—Your standing as a Scout does not depend so much on the skills of your hands or the badges on your merit badge sash, as on the spirit in your heart—on what you are willing to do for others, on whether you are doing your very best to live the Scout Oath and Law, motto and slogan.

Your Scout leaders will know to what extent you live the Oath and Law in your patrol and troop. But that is not enough. Before they are satisfied, they will ask other people to tell them frankly whether they consider you a worthy Scout. Your attitude in your home shows your parents what Scouting has meant to you. Your teachers judge from your actions in school. Your religious leader estimates the influence Scouting has had on you. By weighing all the evidence your leaders will know what kind of Scout you are.

Much of this will also come to the fore as you sit down with your Scoutmaster in a personal conference—the last requirement for each of the higher ranks in Scouting. In this conference you will have a chance to explain to the leader who has guided you as a Scout what the ideals of Scouting have come to mean to you, what you have done to live up to those ideals since you were awarded your previous rank. And also, you have a chance to discuss with him your plans for further advancement in Scouting, the steps you intend to take for reaching a still higher rank.

The Board of Review for Higher Ranks. When you have completed the required number of merit badges, have served satisfactorily the necessary length of time, and have proved your Scout spirit, your Scoutmaster makes out an application for the rank

LIFE SCOUT REQUIREMENTS



To become a Life Scout, you must show by your attendance record that you have been active and dependable in troop meetings and activities for at least 3 months since becoming a Star Scout and do the following:

Service shall be figured from the date of the board of review to the same date 3 months later. For example, the date of the Star board of review was January 10. The boy would be eligible for Life review on April 10.

1. Earn 10 merit badges (these 10 may include the 5 merit badges earned for Star), including at least 5 selected from those specifically required for Eagle (Camping, Citizenship in the Community, Citizenship in the Nation, Cooking, Nature, Soil and Water Conservation, Personal Fitness, First Aid, Swimming, Lifesaving, and Safety).
2. While a Star Scout, plan, develop, and carry out Scoutmaster-approved projects in each of the following areas—
 - a. Church or synagogue, school, or community service.
 - b. Conservation.

Submit one from a and one from b.

3. While a Star Scout, serve actively for a period of at least 3 months as a troop warrant officer (patrol leader, senior patrol leader, assistant senior patrol leader, junior assistant Scoutmaster, instructor, scribe, quartermaster, librarian, den chief) or carry out a Scoutmaster-assigned project to help the troop.
4. After completing the above requirements, meet with your Scoutmaster in a personal conference to discuss your ideas about the meaning of the Scout Oath (or Promise), the Law, motto, and slogan. Give examples to show that you do your best to live up to these ideals in your daily activities. Look over the requirements for Eagle and discuss your progress toward becoming an Eagle Scout.

you are seeking, signs it, and arranges for you to appear before a board of review. For Star and Life, this board may be in your troop. For Eagle, it may be a troop, district or council board.

The members of the board of review are men in your community who are interested in Scouting—and specifically interested in helping you and other boys like yourself have the best possible Scout experience. They are your friends. They will not re-examine you in Scoutcraft requirements, but will question you on what you have accomplished. They will ask you about your service in the troop and to the community. They will want to know how well you live up to the Scout Oath and Law, slogan and motto.

If they are satisfied that you have met all the requirements, they will approve your application and send it to your local council office. Your service record for your next rank begins on the date the board of review approves your application.

Court of Honor for Higher Ranks. Your Star and Life badges may be awarded at some important occasion within your troop. Your Eagle badge may be presented at a troop or a public court of honor ceremony. In some local councils, new Eagles are recognized at special ceremonies.

It is a proud moment for you—but it is an equally proud occasion for your Scoutmaster, your parents, and your friends. All of them have had a share in helping you reach your goal—through their interest and guidance and active help. They deserve your gratitude and your thanks.

It's a proud moment when
you're called up to re-
ceive your Eagle badge.



EAGLE SCOUT REQUIREMENTS



To become an Eagle Scout, you must show by your attendance record that you have been active and dependable in troop meetings and activities for at least 6 months since becoming a Life Scout and do the following:

Service shall be figured from the date of the board of review to the same date 6 months later. For example, the date of the Life board of review was January 10. The boy would be eligible for Eagle board of review on July 10.

1. Earn a total of 21 merit badges, including the following that are required: Camping, Cooking, Citizenship in the Community, Citizenship in the Nation, Nature, Soil and Water Conservation*, Personal Fitness, First Aid, Swimming, Life-saving, and Safety. (Merit badges earned for Star and Life can be used for the Eagle total.)
2. While a Life Scout, serve actively as a troop warrant officer (patrol leader, senior patrol leader, assistant senior patrol leader, junior assistant Scoutmaster, instructor, scribe, quartermaster, librarian, den chief) for a period of not less than 6 months.
3. While a Life Scout, plan, develop, and carry out a service project helpful to your church or synagogue, school, or community approved in advance by your Scoutmaster.
4. After completing the above requirements, meet with your Scoutmaster in a personal conference. At this meeting, complete to his satisfaction the following:
 - a. Discuss your ideas about the meaning of the Scout Oath (or Promise), the Law, motto, and slogan. Give examples to show that you do your best to live up to these ideals in your daily activities.
 - b. Talk over your future in Scouting and what earning the Eagle Scout rank means to you.

* Conservation of Natural Resources will be the required merit badge after December 1, 1967.

OTHER SCOUT AWARDS

Gold Quill Award. This award requires demonstration of ability to write or speak so others can understand. It is awarded by your Scoutmaster. Complete details are in the Gold Quill Award Scoreboard. Earning the Gold Quill gives you credit toward the Communications merit badge.



Eagle Palms. As an Eagle Scout you may earn Eagle Palms for every 5 additional merit badges beyond the 21 required for Eagle rank. The Bronze Palm is awarded for 5, the Gold Palm replaces the Bronze for 10, and the Silver Palm supersedes the Gold Palm for 15. A satisfactory service period of 3 months is required between each award. If you go beyond the Silver Palm, you wear the Silver and Bronze Palms one-eighth of an inch apart on the ribbon of the Eagle badge to represent 20 merit badges, the Silver and Gold Palms for 25, and two Silver Palms for 30.

Trails Awards. The 50-Miler Award and the Historic Trails Award are available to your troop. For complete details see the *Boy Scout Requirements* pamphlet.

Aquatics Awards. Scout Lifeguard and Mile Swim BSA encourage you to improve your skill to help others and to develop physical fitness. See *Boy Scout Requirements*.

Hornaday Award. If you are interested in the conservation of our country's natural resources, you may set out to earn the William T. Hornaday Award, named after the first director of the New York Zoological Society. Applications are available at your council office.

Order of the Arrow. The Order of the Arrow is the national brotherhood of Scout campers. Its purpose is to recognize those campers who best exemplify the Scout Oath and Law in their daily lives and to develop and maintain camping traditions and spirit. The honor of becoming a member of the Order of the

Arrow is one that you cannot set out to earn on your own. This honor is bestowed on a Scout by his fellow campers when he has proved himself worthy of receiving it by being an outstanding Scout in his patrol and his troop and a good and unselfish camper.

Awards by the National Court of Honor

The National Court of Honor makes awards for unusual Scoutlike action and for saving life.

Medal of Merit. A Medal of Merit is awarded by the National Court of Honor to Scouts who perform some outstanding act of service, putting into practice Scout skills and ideals, not necessarily involving risk of life.

Honor Medal and Certificate for Heroism. The highest special award in Scouting is the gold Honor Medal for saving life. This is awarded by the National Court of Honor to Scouts who save life or attempt to save life at the risk of their own and show heroism, resourcefulness, and skill. The Honor Medal is awarded with crossed palms in exceptional cases. A Certificate for Heroism may be awarded for saving life where less risk is involved.



Hornaday Award



Honor Medal



Medal of Merit



Mile Swim BSA



Order of the Arrow



Eagle Palms



50-Miler Award



Historic Trails Award



Scout Lifeguard

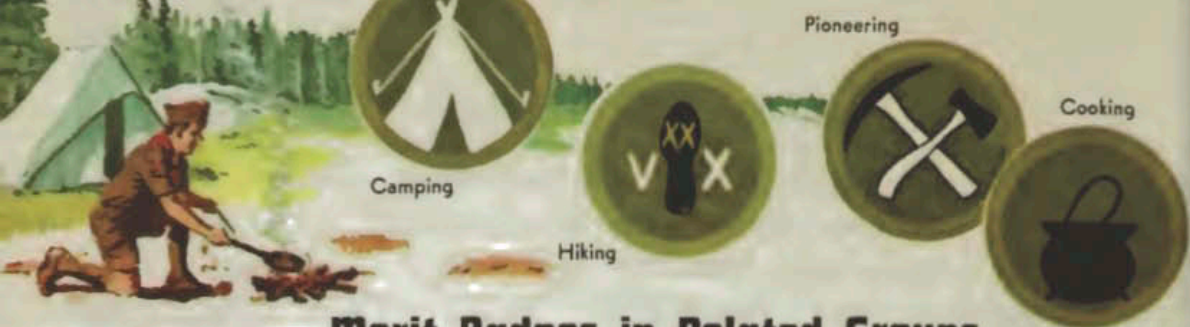

Merit Badges in Related Groups

Campcraft. In this group you will find the most Scouty merit badges. You have already had a taste of the subjects working for your First Class badge—now you can get deeper into them and earn the related merit badges. Camping and Cooking go together like ham and eggs—when you have mastered the requirements for these merit badges, you can make yourself at home anywhere in the open. Both of these merit badges are required for Eagle Scout rank.

Crafts and Collections. Do you like to make or collect things? In this group you will find several merit badges that should give you a further interest in pursuing your hobby. One of the craft merit badges may result in gaining a skill that will enable you to earn a little money. One of the collecting merit badges may lay the foundation for a collection which you will want to continue for years to come.



Archery



Marksmanship



Cycling



Horsemanship



Fishing



Athletics



Skiing



Outdoor Sports. Are you the vigorous outdoor type—or would you like to be? Then you'll find the merit badges in this group to your liking. Here are sports you can pursue year round—from fishing in the spring to skiing in the winter. Some of these merit badges—Archery and Marksmanship, for instance—you may have a chance to earn in summer camp. Hiking may be the outcome of a patrol activity. Horsemanship may be earned by completing 4-H Club or FFA projects in the subject.

Aquatics. "Every Scout a swimmer"—that's one of the physical fitness goals of the Boy Scouts of America. Swimming and lifesaving are practiced in every Boy Scout summer camp. Many of these camps also have the facilities and equipment for rowing and canoeing. Therefore, the simplest way to earn these merit badges is to get to summer camp and spend as much time as possible in the water. Swimming and Lifesaving merit badges are required for Eagle Scout rank.

Small-Boat Sailing



Motorboating



Swimming



Canoeing



Rowing



Lifesaving





Personal Development. In this group are included merit badges that will help you in your efforts to be physically strong and mentally awake. The Personal Fitness badge is required for Eagle—it lays a firm foundation for personal health that may benefit you for the rest of your life. Some of the other badges in this group may start you on your lifework. The Farm Records badge may be earned by completing 4-H Club or FFA projects in the subject.

Conservation. There is an ever-growing awareness in our country of the importance of conserving and using properly our natural resources—our soil and waters, our forests and grasslands, our wildlife, our mineral wealth. Working on one of the subjects of the conservation group, you are not only earning a merit badge, you are also doing an important job for our country's welfare. You may also earn these merit badges by completing 4-H Club or FFA projects. Soil and Water Conservation is required for Eagle.

372



Wildlife Management

Forestry

Soil and Water Conservation

Conservation of Natural Resources

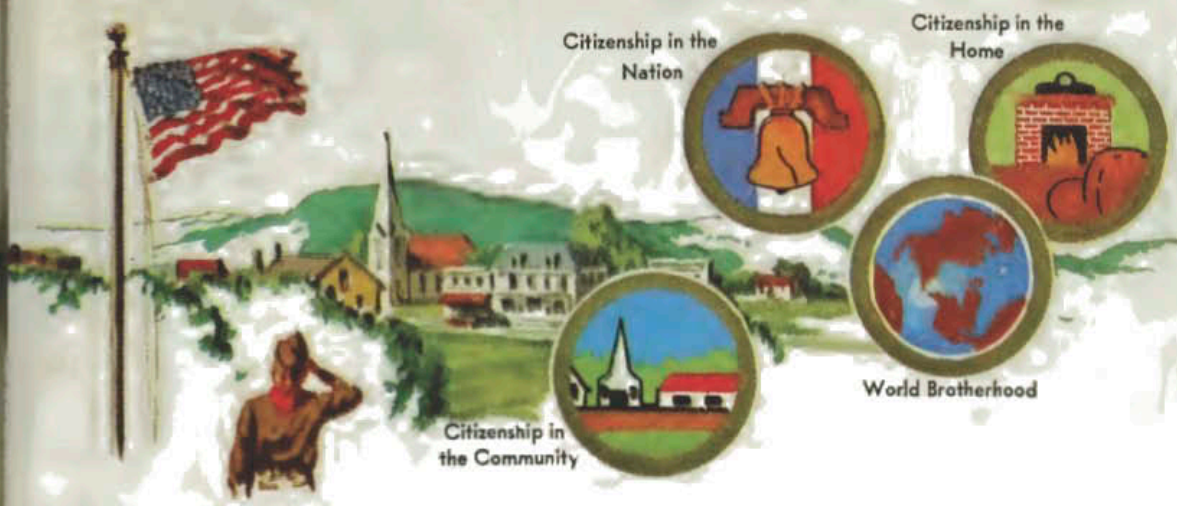

Citizenship in the Nation

Citizenship in the Home

Citizenship in the Community

World Brotherhood

Citizenship. One of the main purposes of the Boy Scout movement is to help boys become good citizens. The Scout Oath and Law point in that direction, many of the tests for the different Scout ranks aim to do the same. One of the finest ways in which you can show what kind of citizen you are is to earn citizenship merit badges—they are not just to be passed, but knowledge that will benefit you in later life. Citizenship in the Community and Citizenship in the Nation are required for Eagle.

Public Service. "To help other people at all times . . ." That's part of the promise you give as a Boy Scout. To be able to do this effectively, you must learn the skills that make it possible for you to be of service. A number of these skills are covered in the merit badges in this group. They are considered so important in Scouting that two of them—First Aid and Safety—are required for Eagle Scout rank.

Firemanship

Fingerprinting

Safety

Public Health

First Aid



Rabbit Raising



Pigeon Raising



Sheep Farming



Dog Care



Hog Production



First Aid to Animals



Poultry Keeping



Pets



Dairying



Animal Industry



Beekeeping

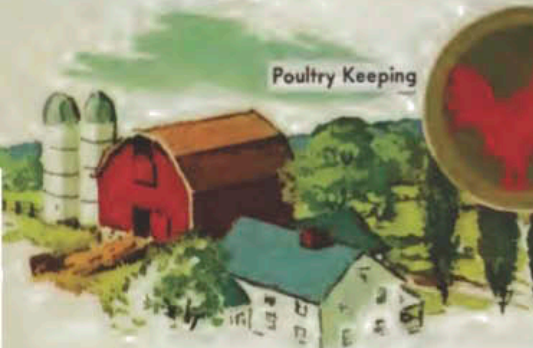

Animal Science. If you live in the country you probably already have had a chance to take care of farm animals or have raised your own rabbits or pigeons. These merit badges should therefore be right in line with your daily interests. Besides passing the Boy Scout requirements, you may also earn the merit badges marked * on page 359 by completing 4-H Club projects in the subjects or in a similar program as an FFA member.

Communications. Knowledge is of little use to us, if we cannot communicate with other people. This group of merit badges offers opportunities for you in a tremendously expanding field that we could call "communicating ideas." Radio and TV, advertising, public relations, printing, public speaking, news writing, and even letter writing are included among these subjects.

Bugling



Radio



Journalism



Communications



Electronics



Printing



Signaling



Public Speaking





Automotive Safety



Aviation



Space Exploration



Transportation. The world is moving so fast these days that a knowledge of transportation is vital to any business effort. The Space Exploration merit badge is included, because its eventual goal is transportation to other worlds, as well as making all parts of our own world accessible in a few minutes.

Arts. Do you have a hobby that requires self-expression or art appreciation? If so, you are almost certain to find a merit badge for it in this group. If you are the creative type, you may want to go in for the Art, Photography, or Sculpture merit badges. If you like to act or play an instrument, you may choose Dramatics or Music. Indian Lore combines several art skills—making things and expressing yourself through dances and ceremonies.



Art



Sculpture



Photography



Drafting



Music



Wood Carving



Pottery



Indian Lore



Dramatics



Architecture



Natural Science. If you are interested in the outdoors or in science, this group will suggest many possibilities. It contains some of the most fascinating subjects in the whole merit badge field. One of them may turn into a lifelong hobby or even into your lifework. Most of these merit badges are a direct continuation of your life as a Scout in the open. Only a couple of them take you indoors for laboratory work. The Nature merit badge is required for Eagle.

Plant Science. If you like to grow things and live on a farm it will be easy for you to earn several merit badges in this group. The subjects to choose will depend on the part of the country in which you live. A couple of the merit badges in this group—Gardening and Landscaping—may also be earned quite easily in the suburban section of a town. You may earn any of these badges by completing 4-H Club or FFA projects in the subject.





Building. The building industry is one of the fastest growing industries in our country. The need for experts in this field will be greater and greater as the population grows. One of the merit badges in this group may open up a career for you. Even if it doesn't, the skill learned will make it possible for you to help with many things around your home. The subjects marked * on page 359 may also be earned by completing 4-H Club or FFA projects.

Materials Science. The use of materials in atomic and space industries has given new impetus to a search for better metals and alloys, plastics, fuels, etc. Scouts who learn all that these merit badges have to offer will have a good start on this important group of scientific subjects.



Metallurgy



Geology



Chemistry



Atomic Energy

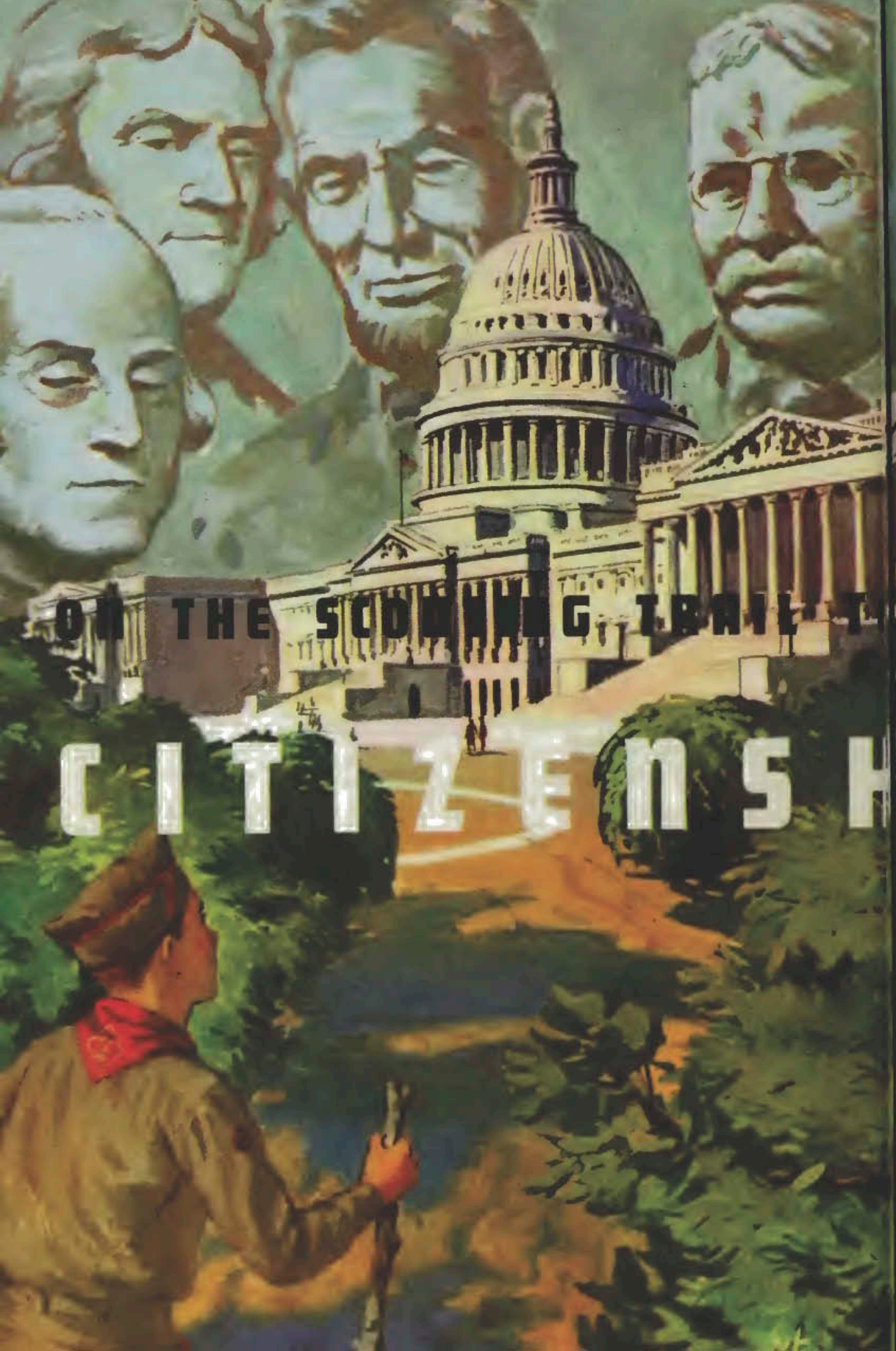

ON THE SCORNING TRAIL TO

CITIZENSHIP

FROM BOY TO MAN



What kind of man do you want to be? There is a simple way to find the answer—by first answering another question: “What kind of man do I most admire?”

Sit down quietly and alone with a pencil and a piece of paper. Then ask yourself: “Which men from America’s past and present do I look up to?” Put their names down. “Why do I admire them? What do I like about them?” Write down the whys and the whats.

High on your list may be your father. And perhaps the names of relatives, your Scoutmaster, your religious leader, your best friends.

Your list may include Americans like Washington because of his loyalty to his country . . . Lincoln for his simplicity and steadfastness . . . Theodore Roosevelt for his enthusiasm and fighting spirit . . . Edison for his energy and perseverance . . . heroes from our wars for their daring and self-sacrifice . . . athletes for their endurance and sportsmanship . . . men of science and arts for their accomplishment in adding to human knowledge and understanding.

You have made your list. There before you in black and white are the qualities you admire most in others, the things that make you like them.

Study those things closely.

See how they add up until they cover each part of the Scout Oath.

They are bound to come out that way, because in the Scout Oath you have the qualities that make men fine and great.

"ON MY HONOR . . ." The signers of the Declaration of Independence pledged to each other their lives, their fortunes, and their sacred honor. Heroes have died rather than betray their honor. As a Scout, you count your honor one of your most valuable possessions.

". . . I WILL DO MY BEST . . ." No person who has accomplished anything worthwhile did this by doing his second best—or his third or fourth best. He gave the very best that was in him—his best thoughts, his best work.

". . . TO DO MY DUTY TO GOD AND MY COUNTRY . . ." The kind of man you will be depends on your ability to know your duty and to do your utmost to live up to your obligations.

". . . AND TO OBEY THE SCOUT LAW . . ." That law fits you as a boy. It will fit you just as well when you become a man—for a *real* man is everything the Scout Law stands for.

". . . TO HELP OTHER PEOPLE AT ALL TIMES . . ." It is not enough to have the willingness to help other people—you need to have the ability as well. You develop this ability as you advance in Scout rank and learn how to act in an emergency.

". . . TO KEEP MYSELF PHYSICALLY STRONG, MENTALLY AWAKE, AND MORALLY STRAIGHT." You owe it to yourself, to your country, and your God to develop your body, to train your mind, to strive to be a boy and man of high character.

In all these things Scouting helps you. By taking part enthusiastically in all activities of patrol and troop, by learning the skills that Scouting has to offer, by living up to the ideals of Scouting, you will become the man you want to be.

"IN GOD WE TRUST." As individuals and as a nation we depend on God.



DUTY TO GOD

The men who founded our nation held the strong conviction that all men "are endowed by their Creator with certain unalienable rights." When they signed their names to the Declaration of Independence they did this "with a firm reliance on the protection of divine providence."

But these courageous men recognized also that for these "unalienable rights" and that "protection," they owed certain obligations and duties to the Heavenly Father of us all.

You learn what these spiritual duties are in your home and in your church or synagogue. Your own spiritual leader, minister, priest, or rabbi teaches you how to know God, how to love Him, and how to serve Him.

By following these teachings in your daily life, by taking part in the practices of your faith, by making use of your leadership ability in your religious activities, you are performing your duty to God as a Scout.

Remember, as you do your duty to God, to be grateful to Him.

As a Scout, living in close contact with nature, you can't help knowing God's handiwork more deeply. As you see the wonders around you, your reverence toward God is strengthened. Sometime when you look up into the starlit sky on a quiet night and realize that Almighty God made this sky with all its stars, thank Him as the Creator of all things.

Also, there are ways in which you can show your gratefulness by deeds.

God has given you a wonderful body and a thinking brain. He has given artists the gift of painting so that they can inspire their fellowmen. He has given writers the power of words so that they can form word pictures of beauty and can lead others to beauty. Composers can stir other people with their music, statesmen can work in the service of their country.

The way to thank God for the abilities He has given *you* is to develop these abilities to the fullest and make the best possible use of them.

You and all men are important in the sight of God because God made you. One way of expressing your thankfulness to God is by helping others—and this, too, is a part of your Scout Oath.

Religious Programs for Scouting

"A Scout is reverent." All Scouts show this by being faithful in their religious duties, but some go further and carry out a program of study, action, and service in their church or synagogue. This may qualify them for a religious emblem. Such an emblem is not a Scouting recognition. It is conferred on the Scout by his religious leader.

To achieve this emblem, you must advance to First Class, give 1 year of service, and learn your specific duties from your own minister, priest, rabbi, ward bishop, or spiritual adviser. The emblem consists of a medal suspended from a colorful ribbon and is worn centered over your left pocket or to the left of your Eagle badge.

The AD ALTARE DEI program is for Scouts who are Roman Catholic. The emblem is a bronze cross suspended by a ribbon in national and papal colors.

The *Ad Altare Dei Record Book* (No. 3093) may be obtained from your priest, your Scoutmaster, or local council office. A *Catholic Manual for Scouts* (No. 3554) will help you prepare yourself.

The GOD AND COUNTRY program is for Scouts of the Protestant faith. The design is taken from the shield of the crusaders, featuring a red cross on a white background. The ribbon is blue.

The requirements for achieving this emblem are described in the *Service Record Book* (No. 4024) available through your Scout leader, your minister, or your local council office.

PRO DEO ET PATRIA is the Lutheran religious emblem. The design is the same as the God and Country emblem, but the inscription on the bar is in Latin instead of English.

For this emblem, secure application form by writing to Lutheran Committee on Scouting, Room 320, 122 West Franklin Avenue, Minneapolis, Minnesota 55404.

The GOD AND COUNTRY emblem for Scouts of the Episcopal Church also uses the crusaders' shield for its design, but the upper left field of the medal contains nine small, white crosses, and the ribbon is red.

382



The *Service Record Book* is available from the National Council, Episcopal Church Center, 815 Second Avenue, New York, New York 10017.

NER TAMID is the religious emblem for Scouts of the Jewish faith. The design represents the Eternal Light found above the Holy Ark in every synagogue.

The *Ner Tamid Program Record Book* (No. 3182) and *The Ner Tamid Guide for Boy Scouts and Explorers* (No. 3178) available from your rabbi, Scout leader, or council office will give you the required information.

The "DUTY TO GOD" emblem may be earned by Scouts of the Church of Jesus Christ of Latter-day Saints. The design is a buffalo skull with a replica of the Salt Lake City temple.

Application cards and requirements may be secured from "Mormon" Relationships Service, Box 2637, Ft. Douglas Station, Salt Lake City, Utah.

The SANGHA emblem is for Buddhist Scouts. The symbol is the Wheel of the Most Excellent Law.

For application form and requirements, write to the Relationships Division of the Boy Scouts of America, New Brunswick, New Jersey 08903.

The ALPHA OMEGA emblem is for Scouts of the Eastern Orthodox-Catholic Church. It is an equal-armed Greek cross in white with a superimposed three-barred cross in red.

Application forms and service record books for this emblem are available from the Eastern Orthodox-Catholic Committee on Scouting, Boy Scouts of America, New Brunswick, New Jersey 08903.

The "IN THE NAME OF GOD" emblem is for Scouts of the Muslim faith. The award, a medallion bearing the inscription "Glory and praise to God is above all," is suspended from a green ribbon.

Application forms and requirements for this award may be secured from the Islamic Committee on Scouting, 3061 West Point, Dearborn, Michigan.

The RELIGION IN LIFE emblem is for Scouts in Unitarian Universalist or other liberal religious groups. The emblem is a red flaming chalice on a white silver-grid globe suspended from a blue ribbon.

The requirements for this emblem are described in the booklet *Religion in Life*, which may be obtained from the Unitarian Universalist Association, 25 Beacon Street, Boston, Massachusetts 02108.



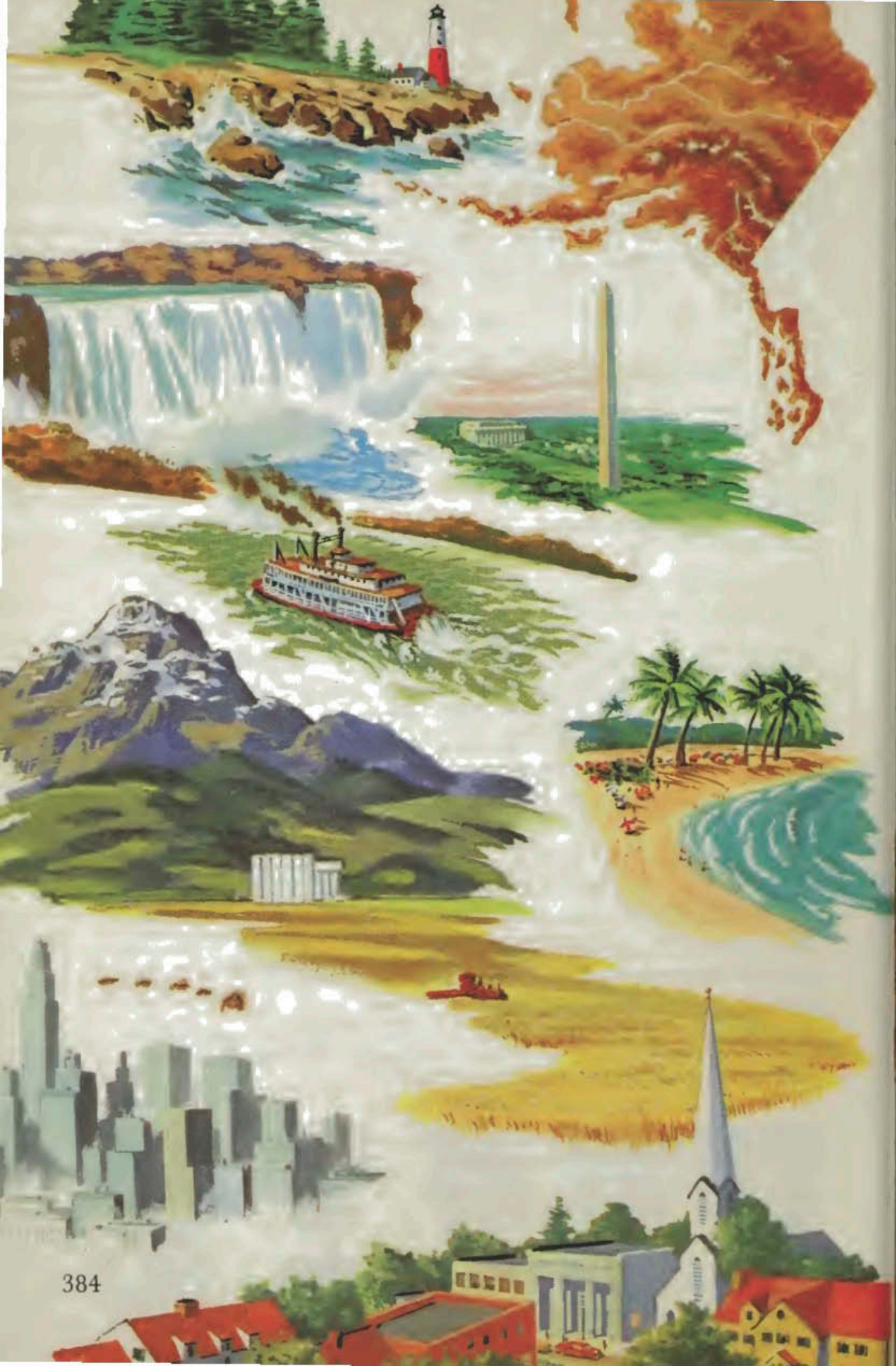

MY DUTY TO MY COUNTRY

The baby in its cradle, the boy or girl at school or at play, the man or woman at work or caring for a family or enjoying their leisure are all American citizens.

Citizenship is your privilege, your right—no one can take it away from you. You are a citizen, now, this very minute.

But because America so generously bestows its citizenship upon you, you owe it to your country to become a good citizen, to do your best to become a true American boy who will eventually grow into a true, upright American man—not to wait until you grow up to become a great man, but to be a **GREAT BOY, NOW!**

The way to become a good citizen is first to **KNOW** and then to **DO**.

America is a land, a people, and a way of life. By getting to know your country you will come to love it. By "helping other people at all times," by working with them, you will come to know the kind of people that Americans are and will learn to get along well with all of them. By studying the past, by learning about the American way of life, you will become an informed citizen who will know what is needed to keep America great.

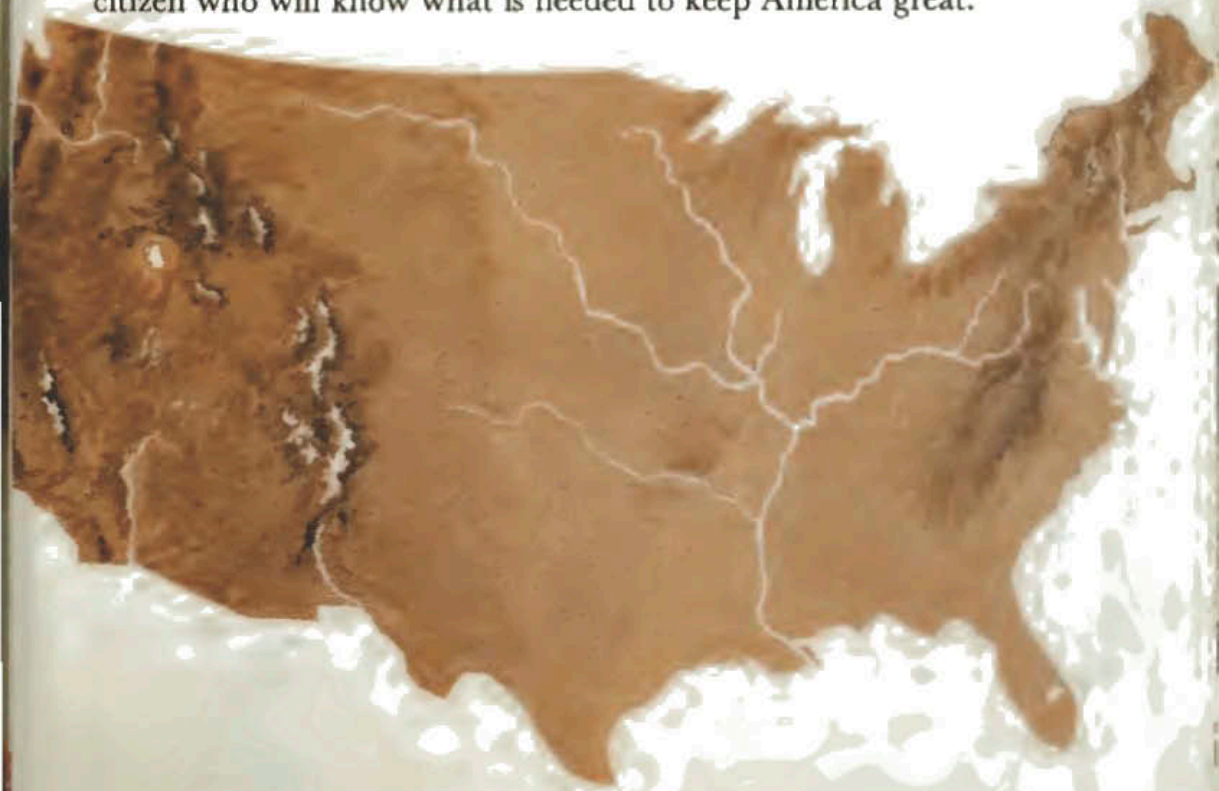

Get To Know America

How well do you know America—your country? How much does it mean to you?

As a Scout you have hiked over its fields, camped in its woods. You have listened to the winds that speed across its plains, the brooks that gurgle through its meadows. But do you really know America? Have you realized its vastness, its beauty, its riches?

Get out a map of the United States of America. Spread it out before you. Look at it with new eyes.

Do you see the sweep of our country—from east to west, from north to south?

Up here, New England shakes a finger at the Atlantic. Down there Florida dips a toe into the Caribbean Sea. The Great Lakes break into the straight line that separates us from Canada to the north. To the south, the Rio Grande forms a winding line along the Mexican border. Way up to the northwest, Alaska stretches a hand toward Asia. The waters of a gulf and two oceans lap against our shores and against the beaches of our outposts—Hawaii, Puerto Rico, and other islands to the west and the south.

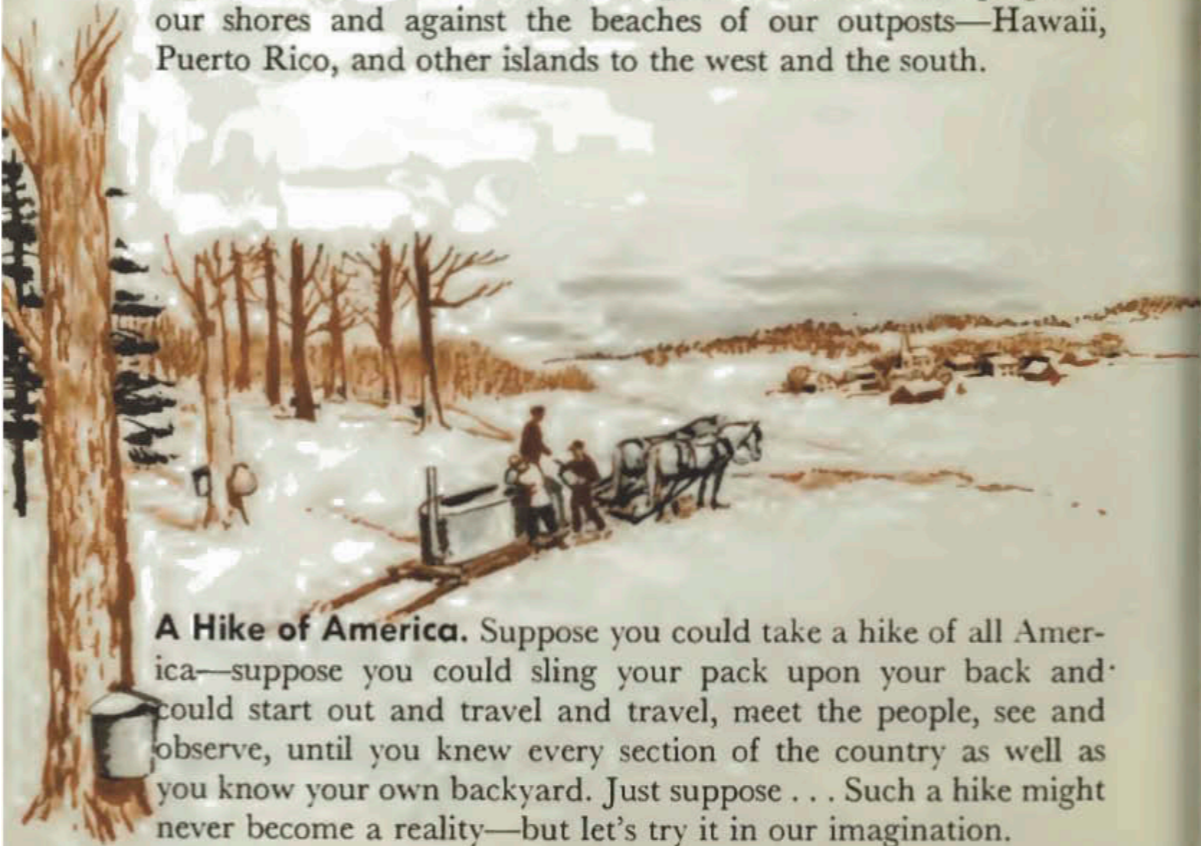

A Hike of America. Suppose you could take a hike of all America—suppose you could sling your pack upon your back and could start out and travel and travel, meet the people, see and observe, until you knew every section of the country as well as you know your own backyard. Just suppose . . . Such a hike might never become a reality—but let's try it in our imagination.

An illustration of a coastal scene. On the left, a small house with a chimney sits on a rocky shore. A wooden pier extends into the water, with a small boat docked. In the foreground, several large logs are stacked on the ground. The background shows a rocky coastline with more buildings and a boat in the distance.

MAINE, NEW HAMPSHIRE, VERMONT, MASSACHUSETTS, RHODE ISLAND, CONNECTICUT . . . We will set out from New England on an early day in spring, at the time when the sap is running strong in her maples, snow still covering the Boston Common. The waves are breaking over the "rock-bound coast" of Maine, singing around Plymouth Rock. Clouds roll low over Mount Katahdin, over the White and Green Mountains, down the bridge of Concord, the village green of Lexington where the first blood was shed for American independence.

An illustration of a statue on a pedestal. The statue depicts a man on horseback, facing left. Behind the statue is a tall, white church steeple. The scene is rendered in a sketchy, artistic style.

. . . NEW YORK, NEW JERSEY, PENNSYLVANIA, DELAWARE, MARYLAND . . . From the thunder of the Niagara Falls to the hubbub of America's largest city we will hike through New York State, then continue through the fertile farmlands of New Jersey, and along the beaches of Delaware Bay. We'll stop at Valley Forge and at Gettysburg and feel ourselves in tune with our country's past. We'll stand before the Liberty Bell and although it will never ring again, we shall hear it in our minds pealing out its message of liberty throughout the land.



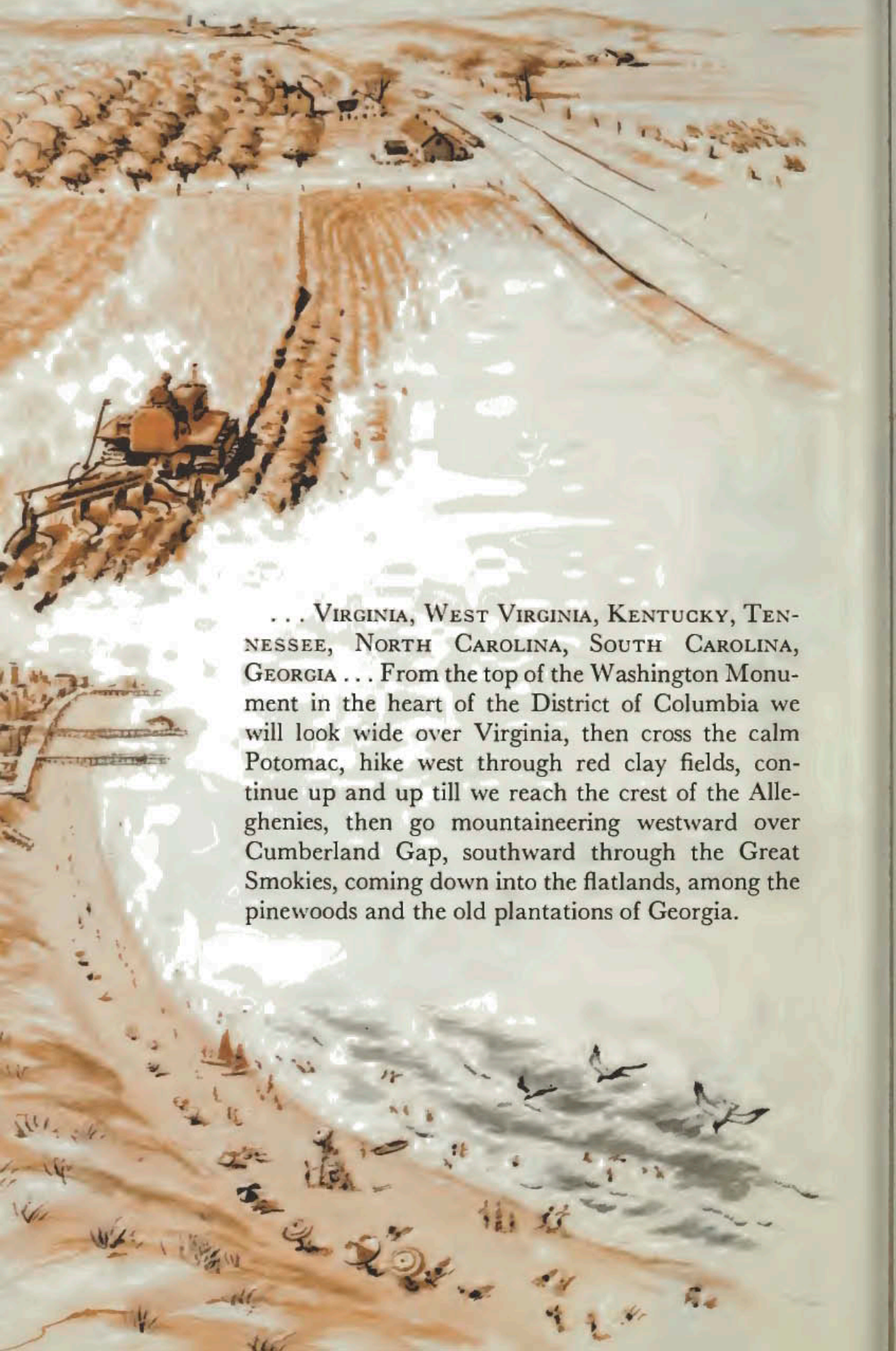

... VIRGINIA, WEST VIRGINIA, KENTUCKY, TENNESSEE, NORTH CAROLINA, SOUTH CAROLINA, GEORGIA ... From the top of the Washington Monument in the heart of the District of Columbia we will look wide over Virginia, then cross the calm Potomac, hike west through red clay fields, continue up and up till we reach the crest of the Alleghenies, then go mountaineering westward over Cumberland Gap, southward through the Great Smokies, coming down into the flatlands, among the pinewoods and the old plantations of Georgia.



. . . FLORIDA, ALABAMA, MISSISSIPPI . . . We will bask in the sun under Florida's swaying palms, explore the Everglades, then follow the old Spanish Trail along the Gulf where the moss dangles in long beards from gnarled live oak trees, till we strike the "long-flowing" Mississippi—"Old Man River" himself.

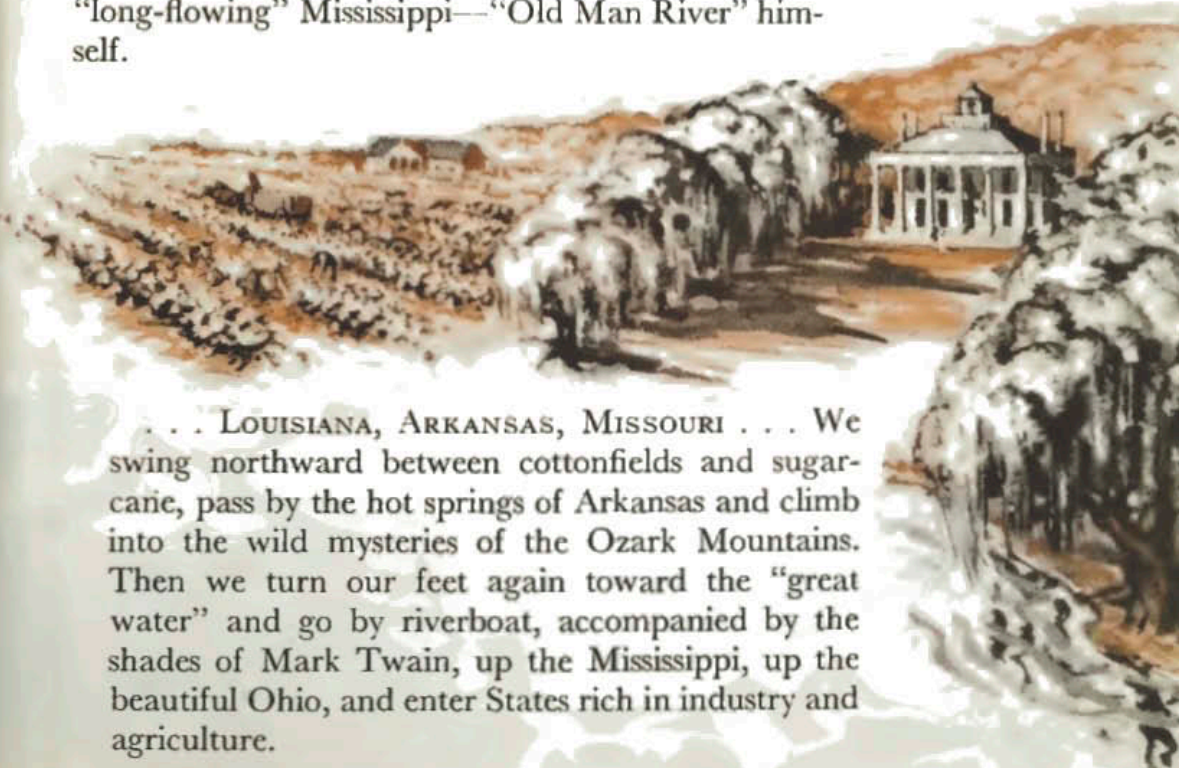

. . . LOUISIANA, ARKANSAS, MISSOURI . . . We swing northward between cottonfields and sugarcane, pass by the hot springs of Arkansas and climb into the wild mysteries of the Ozark Mountains. Then we turn our feet again toward the "great water" and go by riverboat, accompanied by the shades of Mark Twain, up the Mississippi, up the beautiful Ohio, and enter States rich in industry and agriculture.

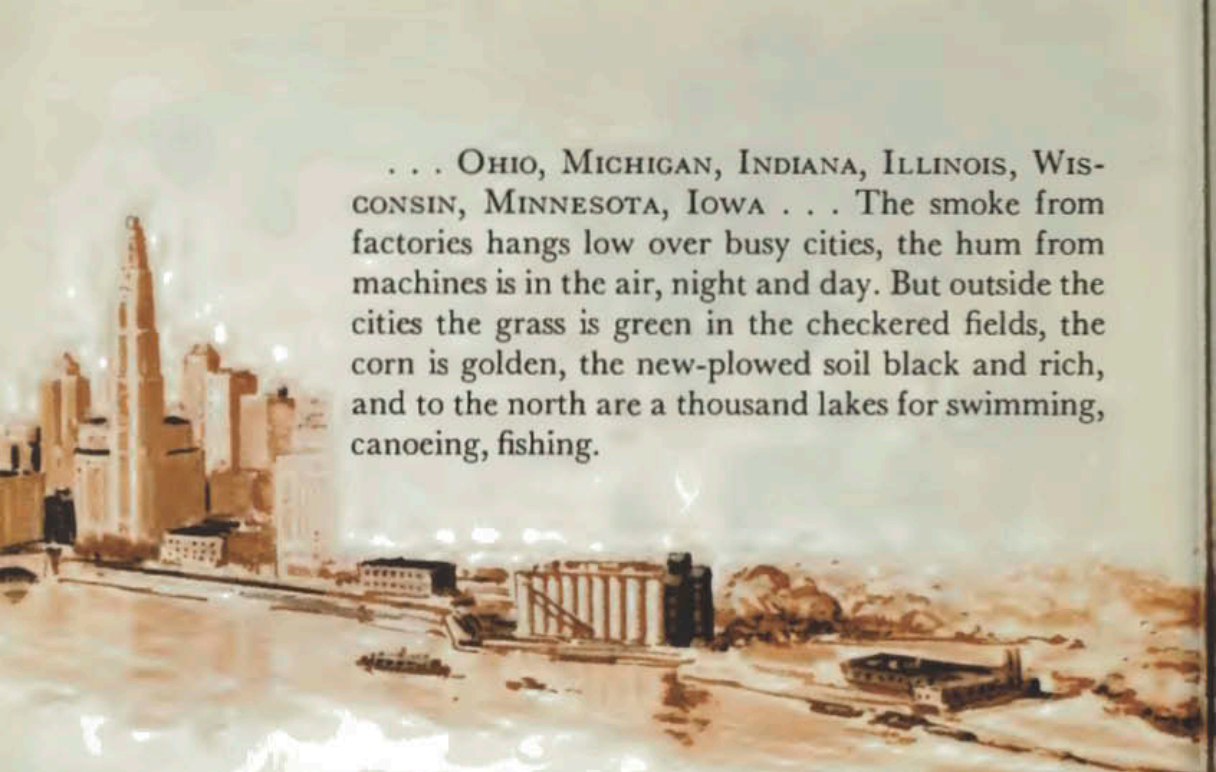

. . . OHIO, MICHIGAN, INDIANA, ILLINOIS, WISCONSIN, MINNESOTA, IOWA . . . The smoke from factories hangs low over busy cities, the hum from machines is in the air, night and day. But outside the cities the grass is green in the checkered fields, the corn is golden, the new-plowed soil black and rich, and to the north are a thousand lakes for swimming, canoeing, fishing.

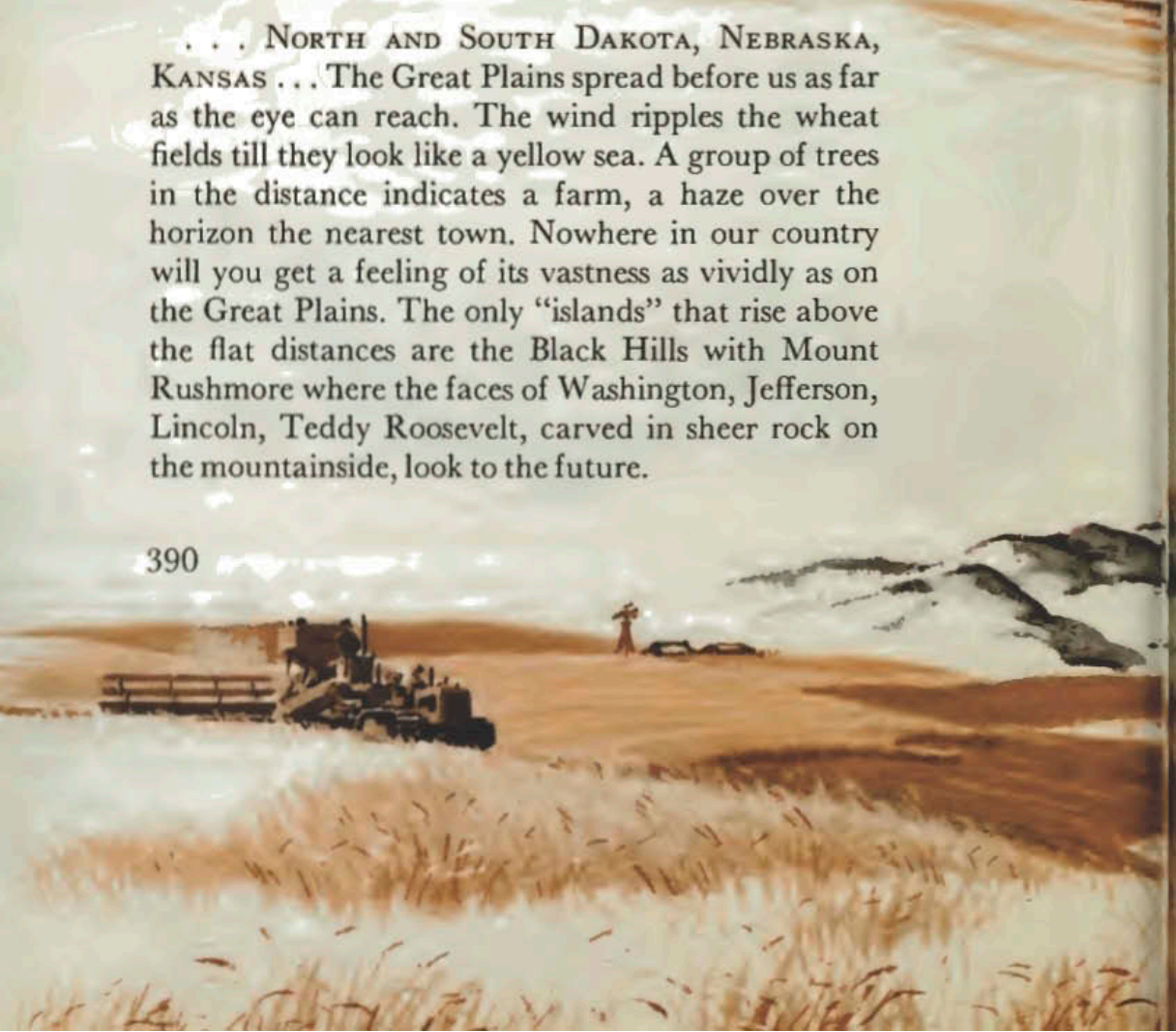

. . . NORTH AND SOUTH DAKOTA, NEBRASKA, KANSAS . . . The Great Plains spread before us as far as the eye can reach. The wind ripples the wheat fields till they look like a yellow sea. A group of trees in the distance indicates a farm, a haze over the horizon the nearest town. Nowhere in our country will you get a feeling of its vastness as vividly as on the Great Plains. The only "islands" that rise above the flat distances are the Black Hills with Mount Rushmore where the faces of Washington, Jefferson, Lincoln, Teddy Roosevelt, carved in sheer rock on the mountainside, look to the future.

. . . MONTANA, IDAHO, WYOMING, COLORADO,
UTAH . . . Beyond the hills the plains stretch out
again, and we follow them as they roll westward
into still more States. But presently the plains become
wavy hills that bump up higher and higher until we
climb into the majestic beauty of the Rockies. As we
follow the snaking roads, snowcapped mountains
rise high above us to one side, to the other are sudden
drops of a thousand feet or more. In Yellowstone
Park we watch Old Faithful send up its steaming
plume. We walk along the white shores of the Great
Salt Lake that lies glimmering in the sun, and we
scale Pikes Peak that stands like a monument to our
Western pioneers.

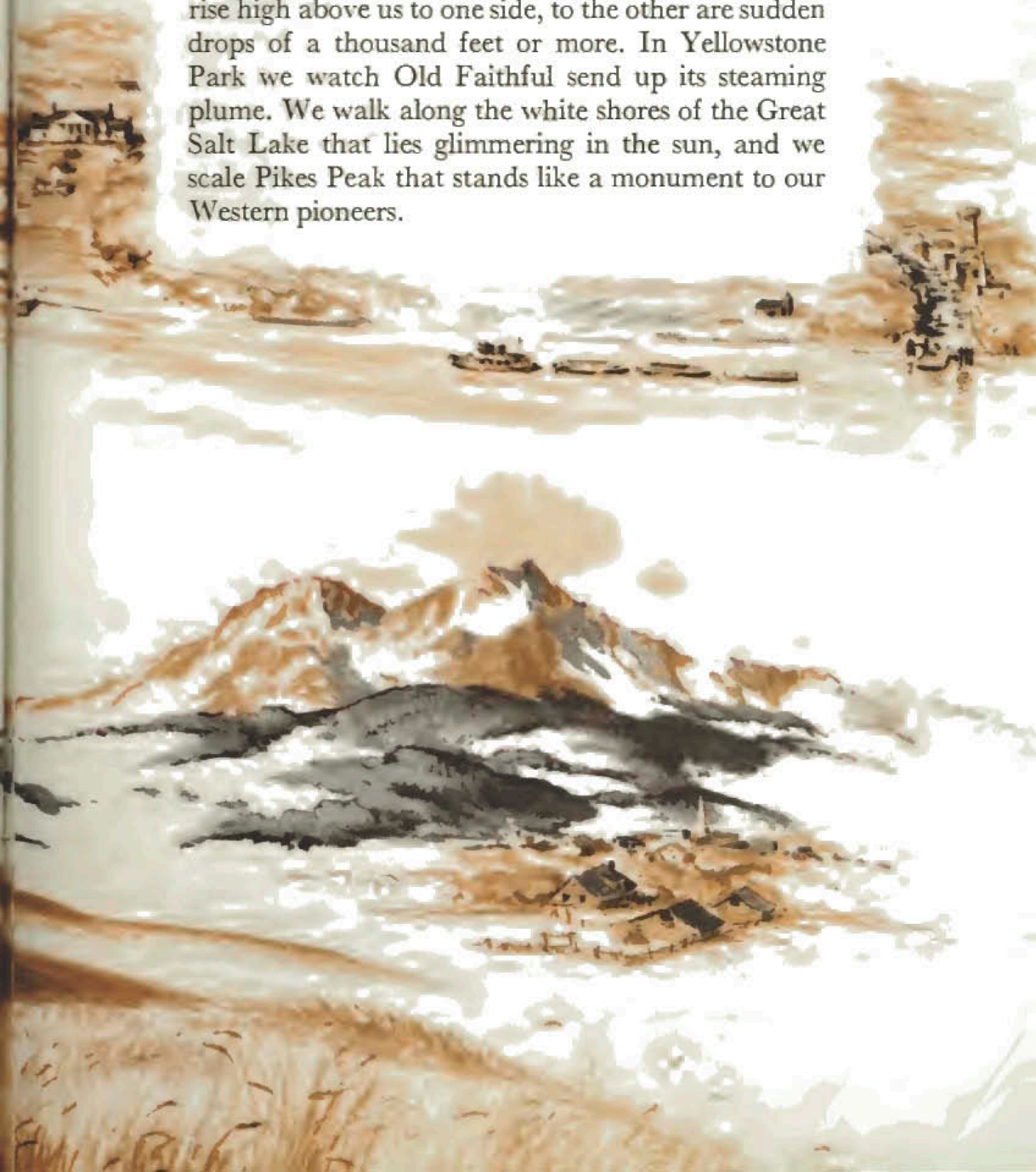



... OKLAHOMA, TEXAS, NEW MEXICO, ARIZONA
... We roam through the oil lands of Oklahoma, the
hunting grounds of the old Cherokee Indians, into
the immensity of Texas. We are in the land of the
cowboy. Cattle by the thousands glare at us from be-
hind strong wire fences. Then we lose ourselves in the
underworld caves of New Mexico and heave a sigh
of relief when again we see the sky above us, and hike
through deserts, glaring yellow and orange and red
in the broiling sun, with cactus plants as tall as trees
standing solemnly on guard.





. . . CALIFORNIA, NEVADA, OREGON, WASHINGTON, ALASKA, HAWAII. California greets us with its sunshine as we wander through it from south to north. But high above the orange groves of the valleys the dark green pines of the snowy Sierras invite us to follow the trail of the eagle—higher, ever higher: Lassen Peak, Mount Shasta, Mount Hood. Then across the mighty Columbia River, and up again, up Mount Rainier itself, till we reach the shining blue waters of Puget Sound where roses bloom in January. After a jump over vast territories of Canada we reach Alaska—one-fifth the size of all the rest of the United States. And finally, we leap across the Pacific to Hawaii—"the loveliest fleet of islands anchored in any ocean," according to Mark Twain.

Our hike is done. We have seen America.
It is vast. It is beautiful. It is rich.
It is OURS—ours to know and to love.



Protect and Conserve the Land

Yes, our country is beautiful, our country is rich. But it will remain beautiful and rich only if every American keeps it so. One of your duties to your country as a Scout is to strive to protect and conserve our land.

The way to do it is to let yourself be guided by the four parts of the Outdoor Code, in your thinking and in the way you act in the outdoors.

Be Clean in Your Outdoor Manners. We sing of America: "O beautiful for spacious skies, for amber waves of grain, for purple mountain majesties above the fruited plain . . ." But as you travel across the country you will find this beauty desecrated by millions of thoughtless litterbugs who have scattered their trash far and wide along our highways, across the countryside, throughout our State and National parks.

It costs more than 50 million dollars a year to pick up the trash along the borders of America's main highways alone. Fifty million dollars! Who pays that enormous bill? Your father does

—your father and every other American taxpayer. Imagine how much good that money could accomplish if we did not have to spend it to clean up after thoughtless people!

The money waste is bad enough. But think also of the forests that go up in flames because of cigarettes thrown from the cars of some speeding litterbugs. Think of streams being choked with discarded cans, pop bottles, cartons, metal trash, old tires. Think of bathing beaches made unsafe to bathers by broken glass. Think of the beauty of our countryside made unsightly by tons of garbage, newspapers, tin cans, bottles, cardboard boxes, wrappers of all kinds.

The way to stop this litter plague is for you to make up your mind that you will never be a litterbug yourself, to do your part to keep your family from ever scattering any litter, and to join the "war" against litter by helping your local authorities remove the trash that is destroying the beauty of the place where you live. A number of Scout patrols throughout the country have pitched in to clean up 500 feet of roadside each. If every Scout patrol did this we would soon have every one of America's highways free of litter.

Be Careful With Fire. Throughout your Scouting experience, care with fire has been an important consideration in your hiking and camping. You know exactly what to do to have a safe fire: how to pick the proper spot for it, how to be positive that the fire can't possibly spread, how to extinguish it completely after use.

As a Scout, with eyes in your head, you may occasionally have to watch out for other people's fires. You will immediately, of course, report any forest fire or grass fire to the proper authorities. But besides, if you live in a forest area, you should find out about fire-fighting methods from local wardens or conservation agencies and be prepared to assist in putting out forest fires.

Be Considerate in the Outdoors. When you are visiting other people you always try to behave in such a way that they will want to invite you back.

Behave the same way in the outdoors.

When the first settlers arrived in America, the whole vast country belonged to everybody. Today, every square inch belongs to

somebody—it is privately owned, or State or Federal property. Wherever you go, you are someone's guest—act like one!

No guest would think of breaking his host's windows or carving up his host's furniture—neither would a Scout damage property he comes upon hiking, or destroy trees and shrubbery where he is camping. No guest would keep a household awake by brawling far into the night—neither would a Scout keep nearby campers from sleeping by loudmouthed behavior.

Be Conservation-Minded. The early explorers found America a land full of natural resources of tremendous value. Forests covered a large part of the country. There was an abundance of fertile soil. Woods, prairies, and streams teemed with wildlife. Minerals of all kinds lay hidden in the ground. The resources were so vast that it seemed as if they could never be used up. So forests were cut and prairies broken and turned into farmland. Water from rivers and lakes was used for factories and mills. Wildlife was slaughtered for food or for sport. Minerals were used in great quantities.

Within a short time, the results became obvious. Where previously forest soil held the water, the exposed land shed heavy rains, causing destructive floods. Fertile topsoil was washed away—or blew away in dust storms. Rivers were filled with silt from eroding farms and wastes from factories. Timber shortages seemed to threaten. Minerals and oil showed signs of giving out.

At last America woke up! Forward-looking Americans realized that a strong conservation program was needed if future citizens were to share in the resources that are the heritage of every American.

From the day of its founding, the Boy Scouts of America has been one of the strongest fighters in the conservation battle. You will want to be in there fighting, too!

Two things are required: first, that you recognize the need for conservation; second, that you do something about it.

To recognize the need, all you have to do is to look around you. Wherever you hike in the outdoors you will notice where



good conservation practices are followed and where they aren't. You will learn from the good ones—and may be able to help improve the situation where poor practices are used.

To do something about conservation, you must know how to go about it. One of the best ways is to earn the three conservation merit badges. In working for the Soil and Water Conservation badge, for instance, you'll learn the importance of soil and water to human welfare; you will have a chance to experiment with these resources; you will find out how best to conserve them; you will carry out projects that will benefit your community. While earning the Forestry merit badge, our great dependence on our forests will become evident to you; you will learn the best practices for growing a forest, for improving it, for harvesting mature trees. The requirements for the Wildlife Management merit badge will take you out into woods and fields to find how wildlife lives; you will get to know the needs of mammals, birds, and fish—how to provide them with food and cover, what practices are necessary to maintain a healthy stock of them for the future.

In addition to working on conservation merit badges as an individual, you will have a chance to work with your patrol and troop on conservation projects. Then, as your interest deepens, you may be the one to set up projects for the other Scouts in the patrol and the troop—showing in this way that you have truly become “conservation-minded.”

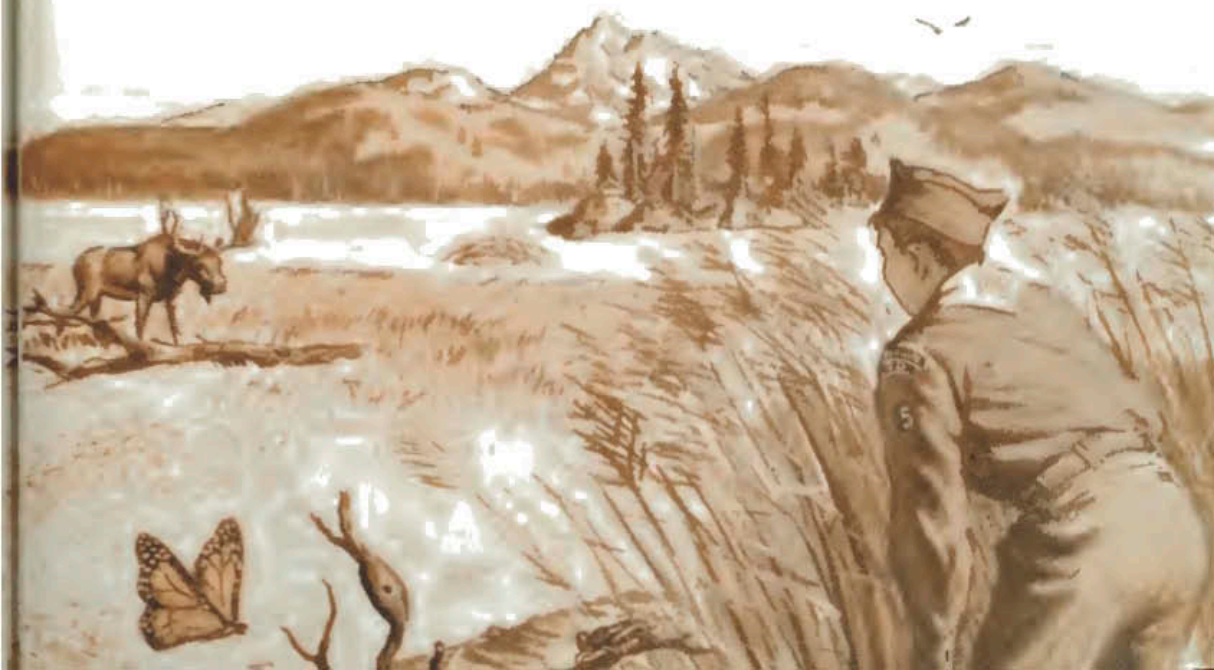



The American's Creed

I believe in

the United States of America as a ¹

Government of the people, by the people, for the people; ²

whose just powers are derived from the consent of the governed; ³

a democracy in a republic; ⁴

a sovereign Nation of many sovereign States; ⁵

a perfect Union, one and inseparable; ⁶

established upon those principles of freedom, equality, justice,

and humanity for which American patriots sacrificed their

lives and fortunes. ⁷

I therefore believe it is my duty to my country

to love it; ⁸

to support its Constitution; ⁹

to obey its laws; ¹⁰

to respect its flag; and ¹¹

to defend it against all enemies. ¹²

Our Democracy

To you and me, America is the finest country in the world. But it is not just the land we love, it is also the kind of life for which America stands—our democracy.

It is your duty as a Scout and as an American to help keep that democracy alive. To do this, you must know the true meaning of America, you must believe in her form of government, you must be willing to do your part to keep America great.

The American's Creed sums up, in the words of great Americans, the things for which America stands. It points out your rights and privileges and your duties as an American citizen.

"I BELIEVE IN THE UNITED STATES OF AMERICA . . ." The United States of America—that's the name of our country, given it by the men who founded it. United, the people of America have worked to give it its present high standards of living. United, we can go on to even greater prosperity and happiness.

". . . AS A GOVERNMENT OF THE PEOPLE, BY THE PEOPLE, FOR THE PEOPLE . . ." Of, by, and for the people—not just some of them, but all of them. Not just the rich or the poor, not just people of one race or one creed, but *all* the people—the people to which the Declaration of Independence refers when it says: "All men are created equal . . ."—not equally gifted or equally rich, but equal under law.

". . . WHOSE JUST POWERS ARE DERIVED FROM THE CONSENT OF THE GOVERNED . . ." Every year, on election day, adult Americans have the right and duty to go to the polls and cast their

The American's Creed was developed by William Tyler Page, clerk of the United States House of Representatives in 1917, in answer to a national contest for such a creed. He incorporated in a brief, clear statement the basic American traditions and ideals, as expressed by the founders of our country and by its leading statesmen and writers.

Key to The American's Creed: 1. Closing words of Preamble to the Constitution; 2. Lincoln's Gettysburg Address; 3. Declaration of Independence; 4. James Madison in *The Federalist*, No. X; 5. Speech by Daniel Webster, Jan. 26, 1830; 6. Preamble to the Constitution; 7. Adapted from closing words of Declaration of Independence; 8. Speech by John Hancock; 9. United States Oath of Allegiance; 10. George Washington's Farewell Address; 11. War Department Circular, April 14, 1917; 12. Oath of Allegiance.

vote about the way they want to be governed. The will of the majority becomes the will of the people—but nothing interferes with the right of the minority to think and say what they like.

“... A DEMOCRACY IN A REPUBLIC . . .” The word “democracy” itself tells of our form of government. It has come to us from the Greek: *demos*, the people, and *kratein*, to rule. But imagine more than 190,000,000 people getting together some place at one time to rule a country! Such “absolute” democracy works all right in a small body such as a Scout patrol, but it wouldn’t work in a whole country where the people are spread out over millions of square miles. Our democracy is therefore the “representative” kind of democracy in which the governing is done by representatives who are elected by the people and are responsible to them. A country ruled in this way is called a “republic.”

“... A SOVEREIGN NATION OF MANY SOVEREIGN STATES . . .” The government of our nation is located in Washington, District of Columbia, the capital of our country. Here, the Congress enacts Federal laws, the Supreme Court interprets them, the executive branch of our government carries them out. But in addition, 50 separate State governments in 50 State capitals enact laws to suit the conditions of their “sovereign” States.

“... A PERFECT UNION, ONE AND INSEPARABLE . . .” The aim of the Founding Fathers was to establish “a perfect union.” But they realized that no union could be “perfect” if it were based solely on human beings with all their faults. They therefore relied



of these many Americans to *die* for our country should make all of us even more determined to *live* for it.

“ . . . I THEREFORE BELIEVE IT IS MY DUTY TO MY COUNTRY TO LOVE IT . . . ” America is your country—her soil feeds you, her laws protect you and give you “the right to life, liberty, and the pursuit of happiness.” America deserves your love. America has a right to expect you to express that love in your deeds, in the way in which you train yourself for American citizenship.

“ . . . TO SUPPORT ITS CONSTITUTION . . . ” The Constitution of the United States explains your rights as a citizen of our country—your right to religious liberty, to freedom of speech and of the press, to assemble peaceably, “to petition the government for a redress of grievances,” to be secure in your person and property, to justice under law. By supporting the Constitution you keep all these rights. But remember that the rights that are yours are the rights of others as well. You have the right to worship God in your own way—see to it that others retain *their* right to worship God in *their* way. You have the right to speak your mind without fear of prison or punishment—ensure that right for others, even when you do not agree with them.

“ . . . TO OBEY ITS LAWS . . . ” The laws of our country, the laws of your State, are written by the representatives of the American people for the good of all Americans. These laws govern much of our behavior in our daily lives. They draw the line between what is right and what is wrong and protect us against those who may want to do us ill. By obeying them you strengthen them and maintain the protection they afford.

“ . . . TO RESPECT ITS FLAG . . . ” The flag is the symbol of our country. When we show it our respect we show our respect and love for all that is America—our land, our people, our way of life. As a Scout you have learned how to handle the flag respectfully, how to display it, how to salute it. By following this teaching all through your life you will always know how to pay the flag the respect it deserves.

“ . . . AND TO DEFEND IT AGAINST ALL ENEMIES.” It is the fervent prayer of all of us that never again shall American men

die on the battlefield. The way to ensure this is to help keep America strong and prepared to stand up against any foreign power that might desire to destroy us. But it is just as important to defend America against the enemies within our own borders—enemies who sow the seeds of distrust among our people, who try to stir up hatred, who attempt to ruin others by lies and smears, who break our laws.

The American's Creed is *your* creed as an American boy. By studying the creed you will know what is expected of you. By following it you will prove yourself a true American.

The Constitution of the United States of America took effect in 1789.

We the People

of the United States, we do hereby give to ourselves, our posterity, and to the People of all the States, the best form of Government that has ever been devised for the good of all.

Article I

Section 1. All legislative Powers herein granted shall be vested in a Congress of the United States, which shall consist of a Senate and House of Representatives.

Section 2. The House of Representatives shall be composed of the whole Number of free Persons, who were bound to Service, in the several States, who shall have attained to the Age of twenty five Years, and seven Years of Citizenship of the United States, and who shall, when elected, be seven Years of Age.

Section 3. The Senate shall be composed of two thirds of the whole Number of free Persons, who were bound to Service, in the several States, and who shall have attained to the Age of thirty Years, and nine Years of Citizenship of the United States, and who shall, when elected, be nine Years of Age.

Section 4. The Electors in each State shall have the Qualifications requisite for Electors in that State.

Section 5. The Electors in each State shall have the Qualifications requisite for Electors in that State.

Section 6. The Electors in each State shall have the Qualifications requisite for Electors in that State.

Section 7. The Electors in each State shall have the Qualifications requisite for Electors in that State.

Section 8. The Electors in each State shall have the Qualifications requisite for Electors in that State.

Section 9. The Electors in each State shall have the Qualifications requisite for Electors in that State.

Section 10. The Electors in each State shall have the Qualifications requisite for Electors in that State.

Section 11. The Electors in each State shall have the Qualifications requisite for Electors in that State.

Section 12. The Electors in each State shall have the Qualifications requisite for Electors in that State.

Section 13. The Electors in each State shall have the Qualifications requisite for Electors in that State.

Section 14. The Electors in each State shall have the Qualifications requisite for Electors in that State.

Section 15. The Electors in each State shall have the Qualifications requisite for Electors in that State.

Section 16. The Electors in each State shall have the Qualifications requisite for Electors in that State.

Section 17. The Electors in each State shall have the Qualifications requisite for Electors in that State.

Section 18. The Electors in each State shall have the Qualifications requisite for Electors in that State.

Section 19. The Electors in each State shall have the Qualifications requisite for Electors in that State.

Section 20. The Electors in each State shall have the Qualifications requisite for Electors in that State.

Section 21. The Electors in each State shall have the Qualifications requisite for Electors in that State.

Section 22. The Electors in each State shall have the Qualifications requisite for Electors in that State.

Section 23. The Electors in each State shall have the Qualifications requisite for Electors in that State.

SCOUT LAW

A Scout is

TRUSTWORTHY • LOYAL • HELPFUL

FRIENDLY • COURTEOUS • KIND

OBEDIENT • CHEERFUL • THRIFTY

BRAVE • CLEAN • REVERENT

OBEYING

THE SCOUT LAW

What Others See. Several points of the Scout Law have to do with your behavior toward people with whom you come in contact. These people have a chance to judge whether you are trustworthy, loyal, helpful, friendly, courteous, kind, obedient,

and cheerful. You prove these things in your everyday actions.

The most important of these people are the members of your own family. They must be able to depend on you. The way you act in your own home shows better than anything else what kind of boy you are.

Other people you deal with soon discover that you can be trusted by the way you keep your promises. They see your loyalty in the way you act at home and in school. They notice your willingness to be of help. They feel your friendliness and courtesy. They observe your kindness to animals and your obedience to your parents, your teachers, your leaders. They respond to your cheerfulness.

You will know from the way they act toward you how well you are obeying these points of the Scout Law.

What You Know Within Yourself. The way you live up to the remaining points of the Scout Law—thrifty, brave, clean, and reverent—is hidden to other people. Some of these traits have certain outward signs—but it is what happens within your heart that makes you know to what extent you have obeyed them.

Thrift, for instance, is more than going to the bank teller's window and passing over money—it is the way you make use of your earnings, your time, your abilities. Bravery is not often shown in heroic deeds—it is more often a matter of overcoming your fear, a decision within yourself to do what is right regardless of the consequences. Cleanliness is more than having a clean face and clean hands—only you know whether your thoughts are clean. Reverence is more than going to church or synagogue—it is the way your faith makes you act when only God is your witness.



HELPING OTHER PEOPLE

When you dedicated yourself to the Scout Oath, you promised to "help other people"—not once or twice, but "all the time."

As you have moved onward and upward in Scouting, your eyes have been opened to the needs of other people, you have learned skills for serving these needs, and the daily Good Turn has become a habit.

To people who know about Scouting the daily Good Turn is one of the finest features of our movement. The record of Good Turns, small and large, that have been done by Scouts since the day Scouting was founded is truly impressive. You have every reason to be proud of the record made by your brother Scouts.

Think of the small everyday things done by individual Scouts, by patrols and by troops: assistance to the weak and the old, service to the sick, first aid to injured people, help in directing traffic, tree planting, bird feeding, and numerous other things.

Then think of the services Scouts have done for their country in two world wars—service upon service, day in and day out: salvaging aluminum, paper, rubber, and iron; selling bonds; distributing government pamphlets and posters; helping the Red Cross; doing civil defense duty. And the services during peace time: our National Conservation and Safety Good Turns, our get-out-the-vote campaigns.

And think of the part Scouts have played over the years in great natural disasters—the Mississippi flood, the St. Louis tornado, the New England hurricane—caring for wounded, putting up emergency kitchens, establishing messenger service, aiding the

police, helping relief workers. The accounts of those disasters carry with them the story of service by Scouts—at times, service until death.

What Scouts have done, Scouts can do! What has been done by others YOU can do! But remember: those others were trained, prepared, willing to help other people.

So get yourself trained to meet any accident, any emergency. Then when the chance comes, you will be ready to do your part, ready to keep alive the tradition of Scout service.

Fires

A Building on Fire. Every year, more than 6,000 Americans are burned to death! You may help hold down this ghastly number by going into action at once if you see a building on fire.

The first thing to do is: **GET THE PEOPLE OUT!** Yell, hammer on the door, ring the bell—**GET THEM OUT!** If the building has an alarm system, set it off.

Next: **CALL THE FIRE DEPARTMENT.**

While waiting for the fire engines, figure out if there is something you can do—then do it with a cool head.

Finally, **OFFER YOUR HELP** where you are needed most.

A Person on Fire. A person's clothes may catch fire from an open flame, or from burning kerosine, oil, or gasoline. The victim's first impulse is to run. It is the worst thing to do. Instead of putting out the fire, running fans the flame.

Rush up to the person, get him quickly to the ground, then

Clothes on fire! Get the victim to the ground and beat out the flames.



roll him over slowly, beating out the flames with your hands. But be careful that your own clothes do not catch fire. If there is a blanket or a rug handy, wrap it around the victim to smother the flames. When the fire is out give him first aid for his burns.

Live Wires

After a storm, someone may stumble over a live wire that has been knocked down; or someone trying to fix an electrical outlet may get a shock; or under certain conditions faulty house wiring may cause an electric accident. Often the victim getting the shock is thrown clear of the wire that caused it and can be given first aid right away. However, if he is still grasping the wire, or lying over it, then it is a matter of fast thinking and fast action.

Electric Accident From House Current. If someone in a home is in contact with a live wire, you can shut off the current by pulling the main switch. Or you can grab the electric cord at a place where it is not bare or wet and pull it from the socket.

If you don't know where the main switch is and can't get the plug pulled out, you will have to try to remove the wire from the victim. To do this, take a DRY handkerchief, DRY towel, DRY sheet, or other cloth, encircle the wire with it, and pull the wire from the victim. Don't touch the wire or the victim. And don't touch grounded objects, such as water pipes.

If you can't encircle the wire with the cloth, use it instead to pull the victim from the wire. Do not touch the victim until he and the wire are separated.

Be sure, in the case of a bathroom accident, to be particularly careful. It is probably best to pull the main switch or call the electric company. There are too many grounded objects in the bathroom. Also, the floor may be wet and it might be hard to get the victim away from the wire.

If the victim is not breathing after the rescue, start artificial respiration immediately. Call a doctor.

Electric Accident From Outdoor Powerline. Rescuing a person in contact with a live powerline outdoors is extremely dangerous business. Do not attempt such a rescue yourself. Call the electric company, police, or fire department instead.

Drownings

Water Accidents. This year, about 6,500 people—mostly boys and men—will drown while swimming or boating or playing in the water. You may have the chance, someday, to prevent one of these drownings.

If you have done lots of camping, you'll have learned to swim and will have had training in lifesaving. When a water accident occurs, it is simply a matter of making use of what you have learned.

The methods are described and illustrated on pages 340-41.

Ice Rescues. During the winter, many people drown by falling through ice. If you witness such an accident, be quick—but think clearly! Decide on a safe way of saving the victim. If you rush headlong out on the ice you'll pretty certainly go in yourself.

If you can reach the victim from shore with a *pole* or a *coat* or a *rope*, do so. Tie a loop in the rope for the victim to put his arm through. It will be hard for him to hold on with numb fingers. At lakes where there is skating, you will often find an emergency ladder. Push the ladder out until the victim can reach it.

If you have to get to the victim over the ice, the main thing is to distribute your weight over as great a surface as possible. Lie down flat and snake out over the ice until you get close enough to throw the rope. When the victim has a firm grasp on it, dig in your skates, then pull him out.

If helpers are available, form a human chain. You crawl out on the ice while someone holds on to your ankles, someone else to his. Grasp the victim by the wrists and snake back.

After you have removed a victim from the ice, keep him moving, if possible. Help him *run* home. Running will bring back some of the body heat. At home, he should undress, rub down with a towel, get into bed. Give him a hot drink.

Of course, if the victim has stopped breathing, artificial respiration should be started immediately.





Other Emergencies

Tornadoes. Almost every year certain sections of our Southern and Central States are swept by tornadoes.

A tornado is a violent whirlstorm, sweeping along from southwest to northeast as a funnel-shaped cloud. In its terrific fury it can lift houses off the ground, tear up trees. Fortunately, its path is usually narrow, only a couple of hundred feet wide, so the chance of being caught is not very great.

The safest place to be during a tornado is underground in a storm cellar. In a home without a storm cellar, a corner of the basement nearest the approaching tornado is safest. If in a basementless house, seek shelter elsewhere.

If you are caught in the open with a tornado cloud directly southwest of you, and you can't get to safety, lie down flat in the nearest ditch, ravine, or other depression. Sometimes you can sidestep a tornado by running quickly toward the northwest or southeast, at right angles to its path.

Floods. In river valleys the thaws of early spring may bring ruin and destruction. When a sudden warm spell melts the snow in upstream mountains and sends the water foaming down, rivers often rise above their normal banks.

Most of the time there's plenty of warning before real danger comes. You can be of service to the authorities by helping people move out of their homes and directing them to high ground.



Someone falls through the ice! Form a human chain and attempt to reach the victim.

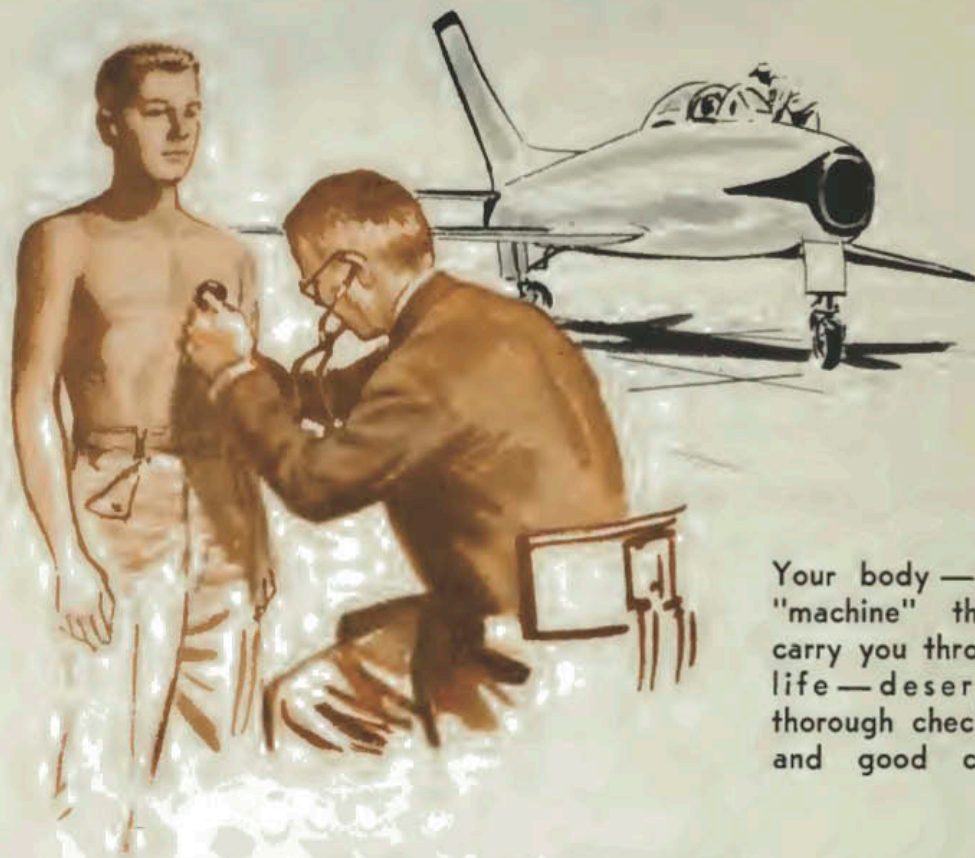

Your body — the "machine" that'll carry you through life — deserves thorough checking and good care.

PHYSICALLY STRONG

Imagine yourself at Kennedy International Airport—one of the busiest air terminals in the world. A whole string of tremendous jet planes are lined up for hops to Europe or South America or around the world. The passengers stream on board. The crew members are at their posts.

The pilots know exactly where they are going and the steps for getting there. But how do they make sure that they'll reach their goal and return?

Do they have their planes thoroughly checked before takeoff? You bet your life they do.

Do they have their instruments tested? Of course they do!

Do they have all possible defects corrected before they speed down the runway? Well, what is your guess?

They don't even trust themselves, alone, to make the final check. They call in master mechanics to inspect the engine, experts to test the instruments, specialists to look over the wings and fuselage and landing gear.

Checking Your Machine. Your body is much like a plane in which you set out on your trip through life. But it is a far more wonderful and far more complicated machine than any built by human hands.

You are its pilot. You should know if it is in order for the journey.

Part of the checking you can do yourself.

If you are in perfect health, you should hardly feel your body at all.

There should be no pains in it and no discomforts. Your appetite should be good. You should wake in the morning cheerful and refreshed, full of pep for the day's play and work. And you should go to bed at night, tired, perhaps, but quickly dropping off to sleep.

But there may be a "knock" in the "engine" somewhere, or a weak part of which you are not aware and which someday may cause you trouble. That's why the proper thing to do is to have an expert give your body a thorough check at regular intervals, say once a year. The expert, of course, is a doctor, and the check is known as a medical examination. This check should be made by your family physician or some other doctor in whom you have confidence.

If he finds your body in fine working order, he will give you a clean bill of health. If he discovers any weak points, he will tell you how to strengthen them.

Growing Into Manhood. In building health and strength, you should keep in mind that you may feel like a man, act like one—but your body itself is not yet that of a man. Your muscles and bones are still growing. Your heart and lungs are steadily increasing their capacity. Glands inside your body are changing from day to day.

From being a boy you are becoming a man.

The way to help build your future health is to keep remembering that you are not yet fully grown and make use of your will-power and patience and common sense.

By following simple and sensible rules of health, you can build a body ready for action, with plenty of reserve energy to carry you through life.

THE FOUR BASIC FOOD GROUPS



1. Meat, poultry, fish, and eggs



2. Milk and milk products

Meat, poultry, fish, eggs—

At least two helpings every day. At least three or four eggs a week.

Milk and milk products—

At least 1 quart of milk daily. Also cheese, ice cream.

Vegetables and fruits—

Citrus fruits or tomatoes every day.

Dark-green or deep-yellow vegetables at least every other day.

Potatoes, other vegetables, and fruits twice a day or as you like.

Bread and other flour products—

At least four helpings daily.

Proper Nourishment

Your Food. Practically anything you eat and drink gives you a certain amount of nourishment. Even a hot dog and a bottle of soda pop contain some nourishment. But if you should try to get along on a steady diet of frankfurters and pop you would soon run into trouble because they lack a lot of things you need.

The food you eat should do three things: it should help you grow; it should give your body tissues and organs (liver, spleen, and others) the material they need to maintain themselves; it should provide you with the energy for your many activities.

The food groups described above and on page 263 form the basis for such a balanced diet. They contain all the foodstuffs, vitamins, and minerals that are necessary for good health.

FOR GROWTH AND GOOD HEALTH



3. Vegetables and fruits



4. Bread and other flour products



Drink Water. Besides solid nourishment and milk, you need plenty of water during the day. Water is necessary for the digestion of food and for carrying away waste. It is also important for regulating the heat of the body.

Getting Rid of Waste. If you eat a variety of foods, get a reasonable amount of exercise, drink plenty of water, you'll develop a regular time for elimination. Don't worry about how often your bowels move—worrying is a frequent cause of constipation. And don't take a laxative if you feel constipated—it throws your automatic mechanism out of gear. Simply drink three glasses of water before breakfast, don't worry—and your trouble will be over.

The idea that your bowels should move once a day or every other day is out of date. The only right schedule is your own schedule.

Plenty of Exercise

If you want strong arms, you must use them—you must pull, push, and swing them in work and play, lift with them, throw with them. If you want to strengthen your legs, you must walk and hike, run and jump. If you want to have an agile, supple body, covered with flat, firm muscles, you must bend it, twist it.

Daily Exercise. When you are out Scouting with your patrol or your troop you get plenty of exercise through hiking, games and contests, swimming, rowing, axmanship, signaling, and many other activities.

Swing into an active Scout life in your patrol and troop. Take advantage of all the outdoor activities of Scouting to build a strong and healthy body.

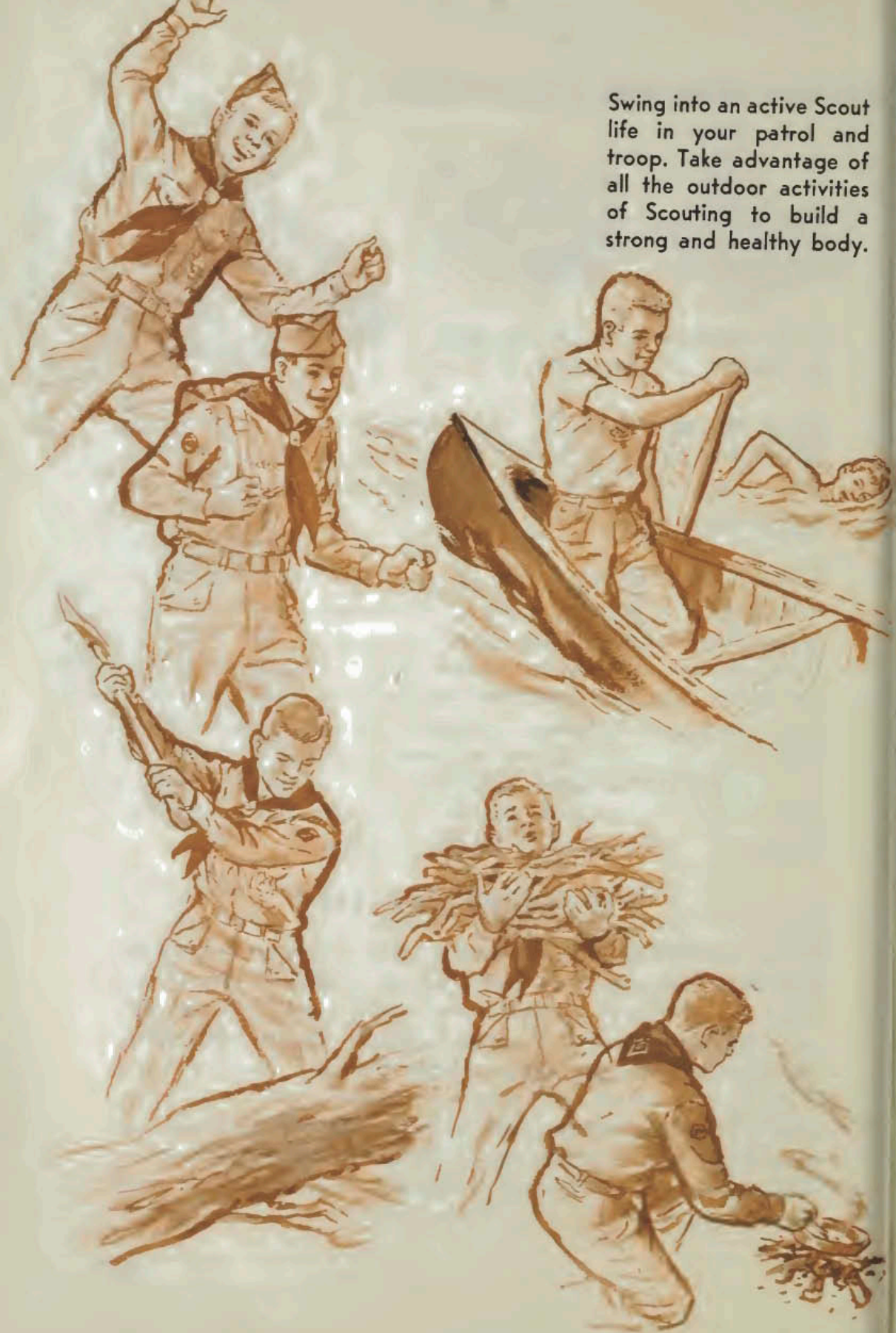

The main thing is to carry some of these activities over into your daily life. Play good swift games—baseball, football, or basketball. Swim in the old swimming hole or in the local pool. Try your skill at skating and skiing if you live in one of our Northern States. Play tennis or golf if that is your ambition. Go in for simple gymnastics and easy athletics.

Do your utmost to improve your body every day during your growing years. The strength, agility, coordination, power, and endurance you build into your body today will benefit you the rest of your life.

Test Yourself. There are three steps involved in making certain that you are actually improving your body. The first step is to test yourself in five simple tests and to compare the result with the standards that are expected of a boy of your age. The next step is to go in for exercises in the tests in which you are weak. The third step is to retest yourself at regular intervals.

Here are the five tests that show how physically fit you are:

SIT-UPS—Lie on your back with legs extended, feet about a foot apart, with a partner holding your ankles. Clasp hands behind neck with fingers interlaced. Now sit up in an erect position, turn body to the left, touch right elbow to left knee and return to starting position. Next time, sit up, turn body to the right, touch left elbow to right knee and return to starting position. One complete sit-up is counted each time you return to starting position. Do as many sit-ups as you can and write down the number on your personal fitness chart on page 417.

PULL-UPS—Put up a bar high enough and easy to grip. Grasp bar with palms facing forward. Hang with arms and legs fully extended and feet not touching the ground. Pull body up with arms until you can place your chin over the bar, then lower body until arms are fully extended. The pull must not be a snap movement, knees must not be raised or legs kicked, body must not swing. One pull-up is counted each time chin is placed over bar. Write down the number on your personal fitness chart.

STANDING BROAD JUMP—Stand on a level surface with feet comfortably apart and toes behind takeoff line. Prepare to jump by flexing knees and swinging arms back and forth rhythmically. Take off from the balls of feet and jump, swinging arms forcefully

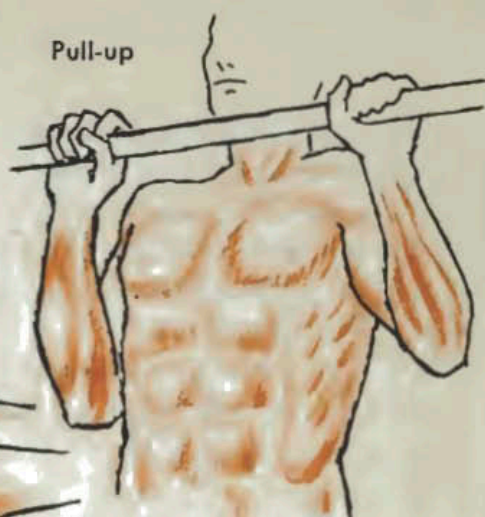
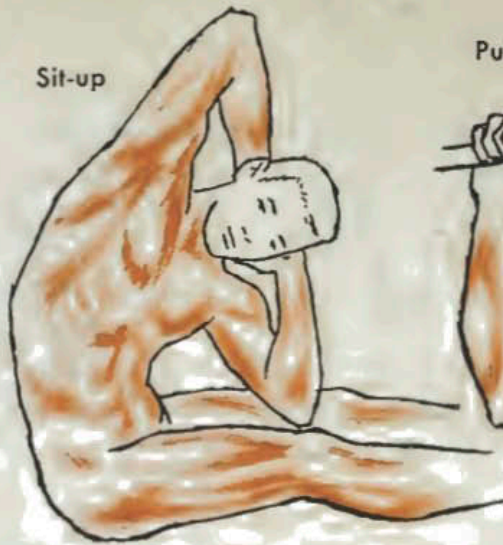
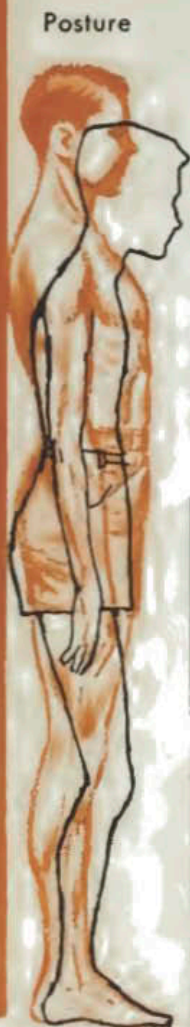

Your Age	SIT-UPS		PULL-UPS		BROAD JUMP		50-YARD DASH		600-YARD RUN (WALK)	
	Good	Excellent	Good	Excellent	Good	Excellent	Good	Excellent	Good	Excellent
	number of times		number of times		FL. in.	FL. in.	Sec.	Sec.	Min.	Min.
11	50	67	4	6	5 4	5 10	7.9	7.3	2:24	2:12
12	51	78	4	7	5 8	6 2	7.5	7.0	2:19	2:5
13	54	83	5	8	6 0	6 8	7.2	6.5	2:13	2:0
14	60	99	6	10	6 7	7 2	7.0	6.5	2:5	1:50
15	60	99	7	10	7 0	7 8	6.7	6.2	1:59	1:43
16	63	99	9	12	7 3	8 0	6.4	6.1	1:51	1:40
17	63	99	10	13	7 8	8 4	6.3	6.0	1:51	1:36

forward and upward. Measure distance jumped from the takeoff line to the heel or any part of body that touches the ground nearest the takeoff line. Record the best of three jumps in feet and inches on your fitness chart.

50-YARD DASH—Measure out a 50-yard course and indicate starting and finish lines. Take your position behind the starting line and place a partner to act as starter at the finish line, with a stopwatch. Starter raises one hand, then brings it down smartly. As he hits his thigh, you start running. As you cross the finish line, the starter notes the time in seconds to the nearest tenth. Write down the time on the chart.

600-YARD RUN (WALK)—Measure out a 600-yard course and in-

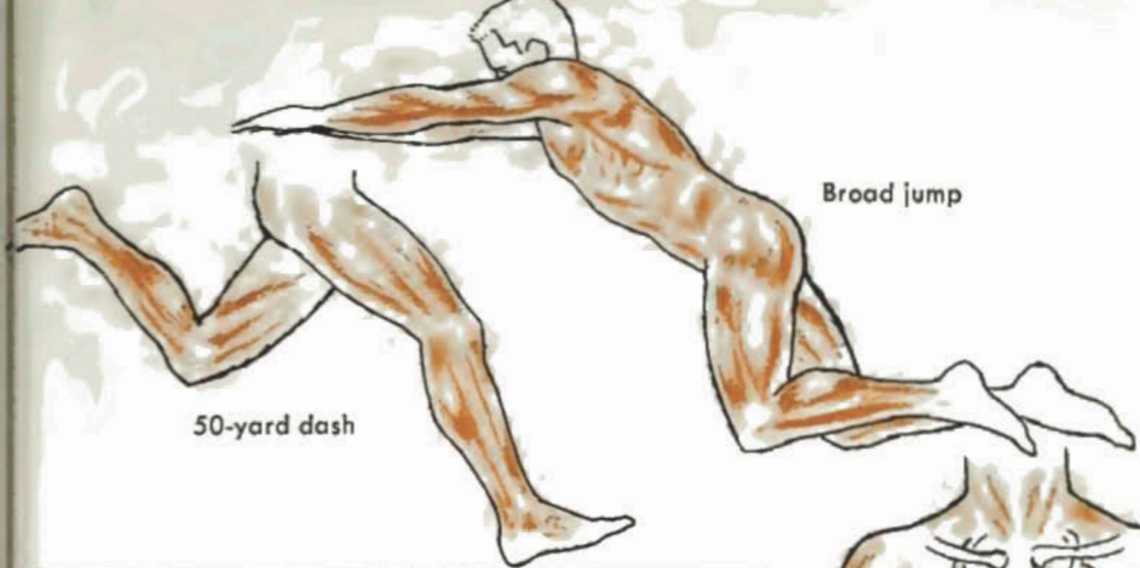

50-yard dash

Broad jump

	SIT-UPS	PULL-UPS	BROAD JUMP	50-YARD DASH	600-YARD RUN (WALK)
DATE	AIM:	AIM:	AIM:	AIM:	AIM:

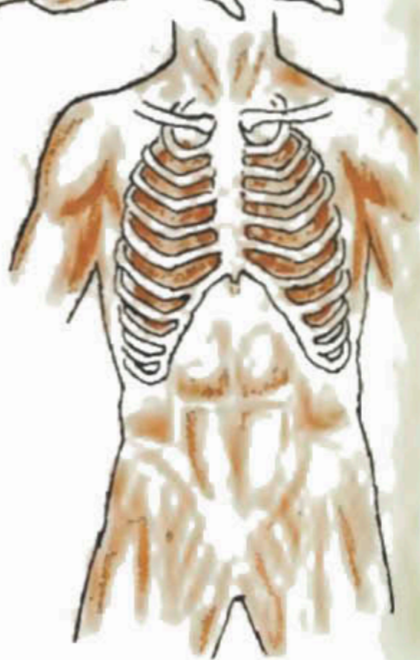

Run (walk)

dicating starting and finish lines. You stand behind starting line. On the starter's signal, "Ready!—Go!" you begin running the 600-yard distance. You are permitted to walk when necessary, but the object is to cover the distance in the shortest possible time. Record time in minutes and seconds on the chart.

Now take a look at the chart on page 416. Find the line for your age and check the standards for boys of your age under each of the five tests. Decide whether you want to be GOOD or EXCELLENT. Write the standards you plan to aim for on the top line of your personal chart and compare them with the way you came out in your tests.

Then set out with determination to improve your record. Train

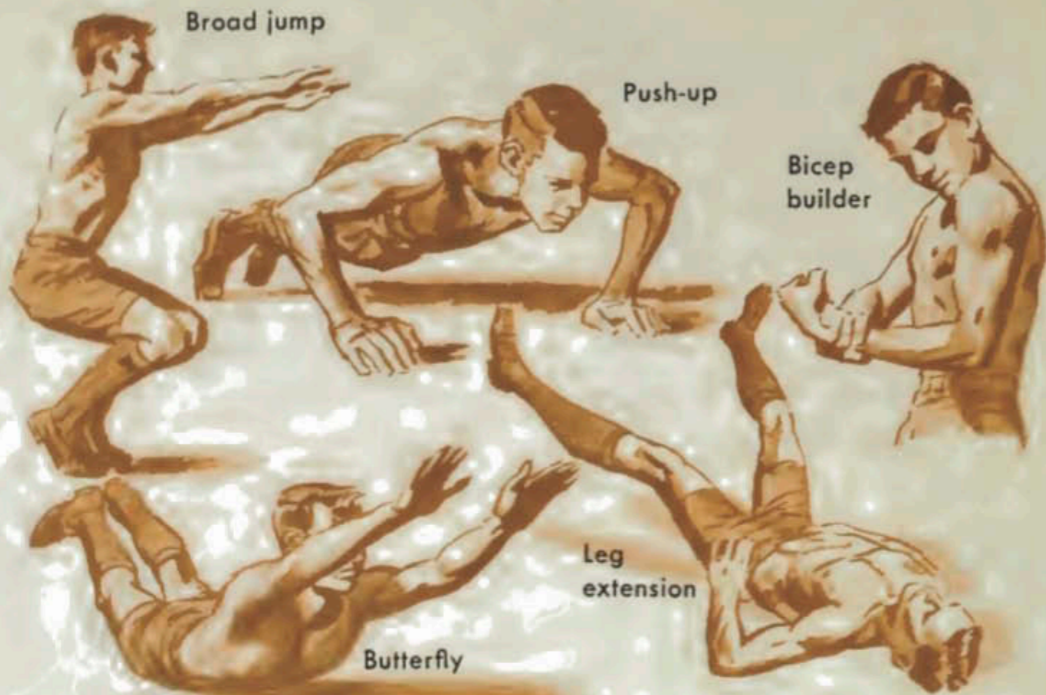

in the five tests and do some of the exercises shown on these two pages—those on this page alone, those on page 419 with a buddy.

After you have exercised regularly for a full month, retest yourself in the five tests and record the result on the chart. How did you make out? Did you show definite improvement? Fine! Keep up improving yourself until you reach the EXCELLENT standard for your age in each of the five tests.

Stand Tall. Proper exercise will help you strengthen your back and stomach muscles. Keeping your back straight is important, too.

There is a very simple trick to good posture: When standing, walking, and sitting, just make yourself as tall as you really are. It should be a comfortable position, a trained effort, not a strained one—shoulder blades flat, shoulders held in an easy natural position, chest up, stomach in.

Thorough Cleanliness

A clean body is a good defense against disease.

The skin is far more than just a covering of the body. Unbroken, it is an armor that keeps out germs, but also, the skin is the largest organ of the body and an important one—two strong reasons for keeping it clean.

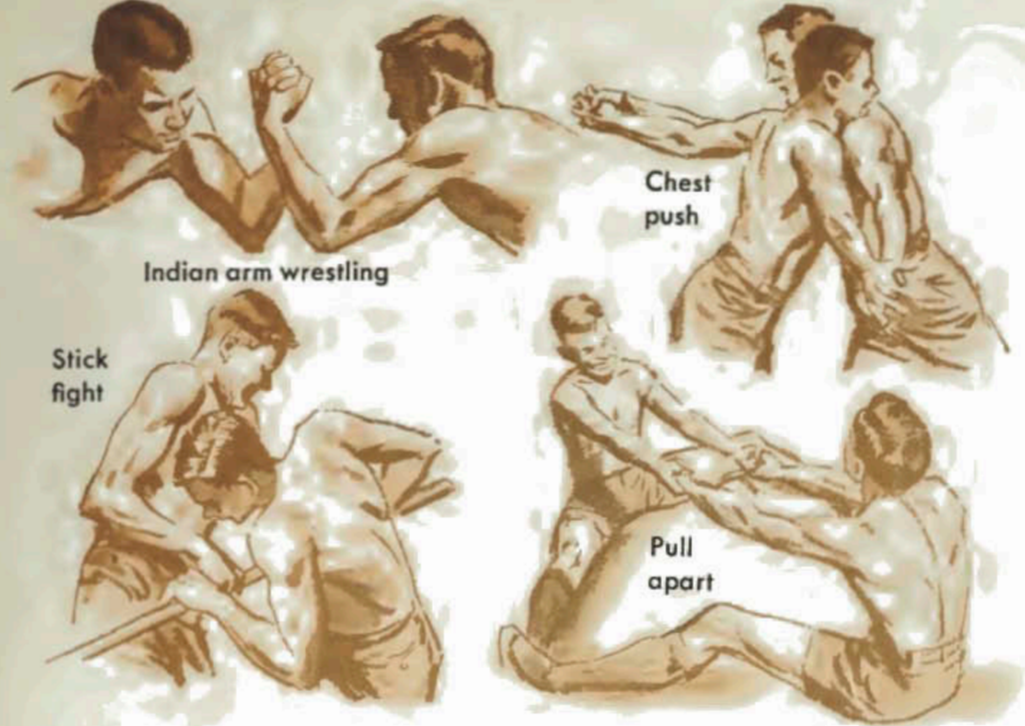

Indian arm wrestling

Chest
push

Stick
fight

Pull
apart

Bathing. Bathe regularly—daily if possible. If you can't get a full bath or shower, you can wash your whole body every day with a wet cloth or towel and follow this by a brisk rubdown, until your skin tingles.



In addition to this quick daily bath, take a more leisurely bath, with plenty of soap and warm water, twice a week, or oftener, and always after a hike or a camp or a strenuous game when you come home grimy and perspiring.

Your Hands. Look at your hands. Other people do and often judge you by the kind of hands you have. If they are clean, with well-kept nails, they give a good impression of you. If they aren't—well. . . .

Get into the habit of washing your hands with soap and nail-brush morning and night, before each meal, following each trip to the toilet, and at such other times as they need it. Then dry them thoroughly.

Here is a hint: If you do a lot of work that causes dirt to collect under the nails, scrape them over a piece of soap before starting work. The soap under the nails keeps dirt out and makes washing so much easier for you.

Trim your nails regularly to proper length with a nail file or



A clean body is one of the signs of a gentleman. Your work may make you dirty—but soap and water will make you clean again.

small pair of curved nail scissors. After cutting your nails, use the thumbnail to push back the skin around the lower part.

Your Feet. Your feet have to support you and move you around throughout your lifetime. Take good care of them. Keep them clean at all times. Cut the nails straight across to prevent ingrown toenails.

Use shoes that are straight on the inside and wide enough to give all the toes room to move. Your socks or stockings should be the right size for your feet. If the foot part is too long it may wrinkle and cause irritation. If too short it will prevent the toes from having free play. Change frequently to clean socks.

Your Hair. Wash your hair about once a week and exercise your scalp by daily brushing and massaging with your finger tips.

Your Teeth. Your teeth are important to your appearance and digestion. Keep them in good working order.

Brush your teeth or rinse your mouth thoroughly after each meal so that all food particles are removed. If you haven't brushed them after supper, be sure to before you go to bed—the chemical action in the food particles will have about 10 hours during the night in which to attack your teeth without being disturbed.

Cleaning the teeth is only one part of tooth care. Have your teeth

examined by a dentist twice a year. That should be done not only for the sake of your teeth but to ensure health for your whole body.

Your Eyes and Ears

Your Eyes. One of the worst calamities that can happen to you is to lose your sight. You have only two eyes. Take care of them!

Look in the mirror to see whether the pupils of your eyes are black and bright and the white a clear white. They should be. If your eyes are bloodshot, or if they hurt or get watery often, it is a sign of eyestrain, which may be caused by wind or smoke, lack of sleep, reading too much in poor light, or an eye defect.

If your eyes bother you in any way, have them examined by an eye specialist and follow his advice. Without your knowing it, poor eyesight may be holding you back in school.

Your Ears. As far as your ears are concerned, keep the outside part of them—the “trumpet”—as clean as the rest of your head by using a damp cloth over the end of a finger. Let nature take care of the inside. Never dig in your ear with any kind of hard object. You may infect the canal or even break the eardrum and lose your hearing.

Eardrums are sometimes broken by headfirst high diving. Diving feetfirst without holding the nose may force water through the nostrils up into the inner ear and cause trouble. In swimming, if the water bothers you by filling your ear canal use rubber ear stops.

If you have any trouble with your ears, such as constant ringing in them, “running ear,” or earache, see your doctor.

Sun and Fresh Air

How To Tan. Every real boy prefers the suntanned skin of the outdoorsman to the pasty-white skin of the stay-at-home. So, by all means, use every opportunity to let the sun play, but not work, on your body. .

Take pride in getting a tan instead of a burn. If your skin is sensitive, the way to get a perfect tan is to expose your skin the first day for not more than 10 to 15 minutes. If your skin is red the

next morning, wait until most of the redness has disappeared before another exposure. Then get into the sun for another 10 or 15 minutes. After this, you can usually add 15 minutes a day so that within a couple of weeks you have a deep tan and can be exposed to the sun most of the day. If you tan easily, you may increase the length of exposure much faster.

Breathing Properly. To live and grow, each cell of your body must have a steady supply of oxygen from the air, day and night. If your air supply were cut off you would die within minutes.

If it were just a matter of getting air to the lungs, it wouldn't make much difference whether you used your nose or mouth for breathing. But it isn't. The nose prepares the air for the lungs, the mouth doesn't. The damp lining of the nose moistens the air. The warmth of the nasal chambers heats it. The numerous tiny hairs that cover the inside of the nose stop the germ-filled dust. Thus, by breathing through the nose the lungs receive moist, warm, filtered air. By breathing through the mouth, cold, dry, dirty air fills them.

So keep your mouth shut and the passage through your nose clear. Always blow your nose gently and one nostril at a time, never both together. If you have trouble breathing through your nose, let a doctor take a look at it.

Sufficient Rest and Sleep

By the time you are 60 years old you'll have spent 20 years in bed. A terrific waste? Not at all! Sleep is nature's way of charging the human battery, of storing up new energy in the body. It also gives the body the chance to replace old tissues and to build new—in other words, to grow.

How much is sufficient? A boy from 11 to 16 needs about 10 hours sleep each night to feel his best. The reason for so much sleep is that you are at the age when the greatest growth occurs



and when therefore most sleep is required. And it's also the time when you are always on the go in all kinds of activities. It isn't how little you can get by on—it's how much you should have to be at your best. It will take a lot of planning on your part to see to it that you get enough rest and sleep and yet get everything done you meant to do and have to do—including your schoolwork.

How To Sleep. To sleep well, your bed should not be too soft, nor should it sag. If it does, get a sheet of plywood to place under your mattress. Your covering should be light and just warm enough.

Sleep in fresh air. Sleep outdoors as often as you can—under the open sky or in a tent (but don't close that tent door!). At home, have a window open so some fresh air will come in during the night—but not so much that you'll get cold.

Staying Healthy

Accidents. More young people die from accidents than from any other cause. In addition to those who die, thousands are injured—many of them permanently. Don't let that happen to you.

Here's what you can do about it:

LEARN SKILLS TO MAKE YOU SAFE. There is a safe way of doing everything: swimming, bicycling, paddling a canoe, using an ax, playing baseball. Practice the proper use of tools. Learn thoroughly the rules of sports you like. "Safety through skill" is a Scout slogan. Follow it!

USE SENSE TO KEEP YOU SAFE. It doesn't take skill to cross a railroad track, but it takes common sense not to do it when a train is coming. It is common sense to use a stepladder instead of a chair when you have to reach high, to keep away from strange dogs, to fix a loose handle before using an ax, to pick up broken glass before you or someone else gets hurt.

Protecting Yourself. Your best weapon against disease is a healthy body.

But that is not enough unless you use ordinary care.

Keep away from anyone who suffers from a communicable

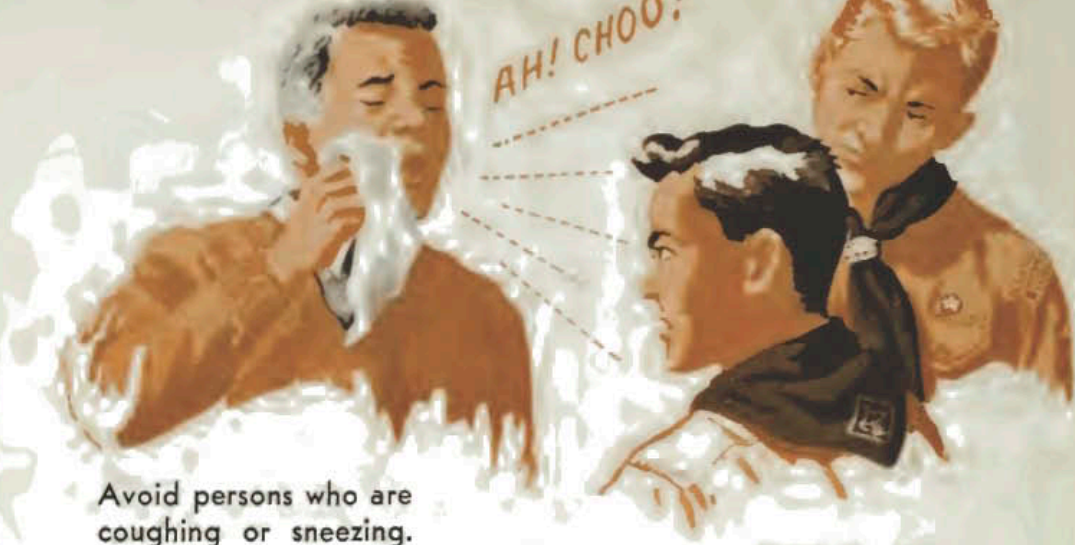

Avoid persons who are coughing or sneezing.

disease—that is, a disease spread from one person to another. Avoid persons who are coughing or sneezing.

Never use a drinking cup or eating utensils that have been used by others, until they have been properly washed.

Use your own bath towel, washcloth, and handkerchief.

In camp keep flies away from you and your food.

Stimulants and Narcotics. Stimulants are drugs that excite the nervous system and speed up heart action. Coffee and tea are stimulants. Narcotics are drugs that depress and slow down mental and bodily functions. Tobacco, alcoholic drinks, such extremely dangerous drugs as marijuana and heroin, and many others are in this class.

COFFEE AND TEA—Milk is far better for growing youngsters than coffee or tea. Milk is nourishment—coffee and tea, except for the milk and sugar added, are not. Milk contains numerous things you need for your growth—clear coffee and tea contain none.

TOBACCO—After many years of careful research, medical authorities have come to the conclusion that cigarette smoking is a serious health hazard. It may cause lung cancer and may weaken the heart. Even the most confirmed users of tobacco won't claim that smoking does any good but will admit that smoking may do harm. Your health is one of your most valuable possessions. Smoking may impair it dangerously. You are better off without tobacco—so why start using it?

ALCOHOL—One look at a drunken man staggering down the

street will convince you that alcohol indeed does slow down mental and bodily functions. Alcohol is avoided by every young person who wants to be in the best of health. It does no good and can do a great deal of harm. It will pay you to stay away from it.

From Boy to Man. At the age of 13, 14, or 15 (sometimes earlier, sometimes later) you not only grow, but numerous changes take place in your body. Your voice changes. Hair appears on your face, in the armpits, around the sex organ. Your sex organ increases in size.

All these changes are caused by the function of the sex glands or testicles. They produce fluids or secretions that have a great effect on your development.

At times the glands discharge part of their secretions through the sex organ during sleep. This process is called a nocturnal emission or a "wet dream." It is perfectly natural and healthy and a sign that nature has taken care of the situation in its own manner.

There are boys who do not let nature have its own way with them but cause emissions themselves. This may do no physical harm, but may cause them to worry.

Any real boy knows that anything that causes him to worry should be avoided or overcome. If anything like this worries you, this is not unusual—just about all boys have the same problem. Seek the correct answer to any question which bothers you about your development from boy to man. But be sure to get your information from reliable sources—your parents, your physician, your spiritual adviser.

A Healthy Attitude

You will find that living the Scout Law is a great help in your efforts to make you keep yourself physically strong.

By doing your best to be cheerful, friendly, brave, and clean, worries, irritation, and "blueness" disappear, and with them fatigue, loss of appetite, and inability to sleep. A feeling of success, ambition, confidence in yourself, and excitement over things that life has to offer take their place.

"As a man thinketh in his heart, so is he!"

Think yourself strong, do something about it—and you are on your way to being strong!

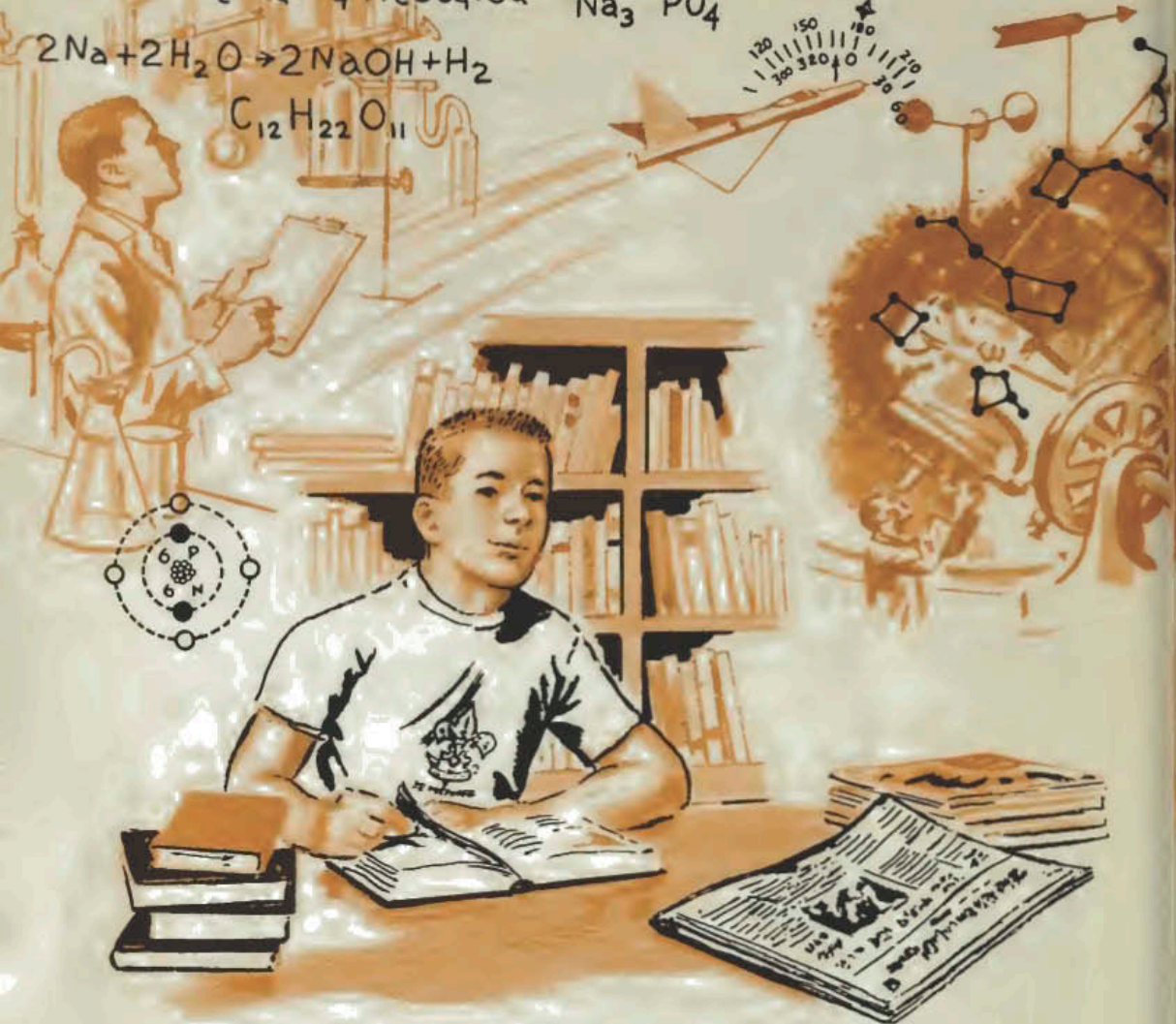

MENTALLY AWAKE

“Mentally awake . . .”—in everything you do or think—that’s part of our Scout Oath. What you make of yourself depends to a large extent on your mental alertness.

The boy who is mentally awake has more adventure in a day than a dull boy has in a month. He gets more out of life—and he gives more to other people. But also, he has a far better chance of creating a successful career for himself.

Learn To Think

In today’s world, the most important thing you can learn to do is to **THINK**.

The ability to think—and especially to think fast—usually

$$2wV\sin\phi = \left(\frac{1}{\rho}\right)\left(\frac{\Delta p}{h}\right)$$

$$\int \nabla \times \Phi$$

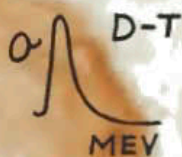

$$E = mc^2$$

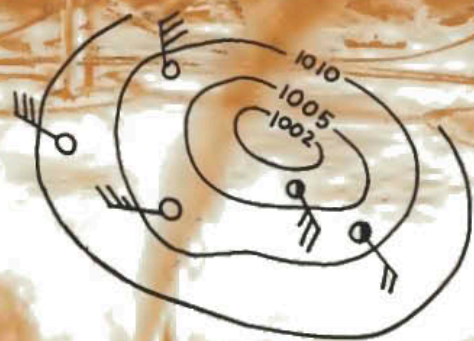

30 // Z 963
4 * * • +28
30 --- 6 • 4
3 .45

goes with a mind that is alert and interested and always inquiring. Thinking fast in an emergency also depends on the habit of figuring things out in advance. That's the case when your best pal gets hurt playing football in the corner lot. You get him to the nearest doctor while the others are still standing around stunned. You do it because you've thought out in advance what you would have to do if just such an accident should happen.

The Art of Concentration. Does your mind jump from one thing to another like a flea? Or does it stick to the job on hand? You have to keep your mind constantly alert if you expect to keep it from drifting

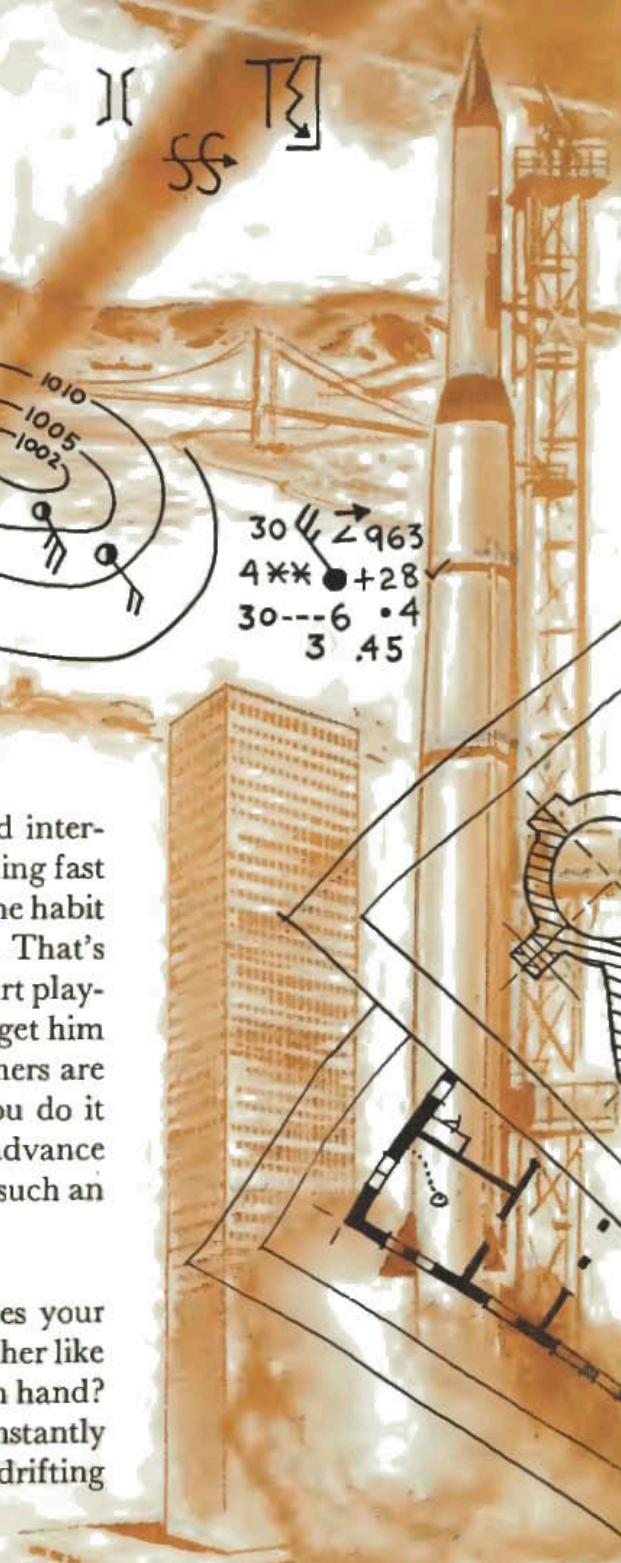



—are you able to do it? (Just for fun, keep a check on yourself and see how many times your mind wanders as you read this page.)

Some fellows seem to accomplish as much in 1 hour as others do in 2. They can finish their studies more quickly. They have ample time for all sorts of other interests—hobbies, athletics, reading. Often this is not so much because of superior ability but because they have learned how to keep their minds on what they are doing and think of nothing else. They know how to concentrate.

Concentration is made up of willpower and self-control.

During an exciting baseball game you often become so absorbed in the play that you are unaware of everything around you except the ball and the players. No difficulty about concentrating here. Bring that same intense quality to your work and see how much more you can get done.

Give yourself a definite length of time to accomplish a certain



COIUGETIS OSSA MEA
 HINC UOBIS CUM ET
 MORTUUS ES NOS

Psalm
 XXIII



JANUS						
I	II	III	IV	V	VI	VII
VIII	IX	X	XI	XII	XIII	XIV
XV	XVI	XVII	XXVIII	XIX	XX	XXI
XXII	XXIII	XXIV	XXV	XXVI	XXVII	XXVIII
XXIX	XXX	XXXI				

amount of work—say, tomorrow's algebra or next day's English composition. Force yourself to keep your attention on the job you are doing. Then finish on time.

Don't put off a job that has to be done until you feel like doing it—do it and get it over with!

Do things often enough in this determined way for it to become a habit. After that you'll be sitting pretty while the fellow who hasn't learned to concentrate struggles along, never quite making the grade.

Think With Your Eyes, Too. There's a way of thinking with your eyes in addition to your brain. How? By *observing* instead of just looking.

The observation games you play in Scouting, tracking and stalking, help you develop this power of thinking with your eyes.



Things you see impress themselves on your mind. And from what you see you are often able to make valuable deductions.

James Watt noticed that the lid of a kettle of boiling water popped up and down. Thousands of others had seen the same thing, but Watt observed. And from what he observed he deduced that it was the steam that had the power to lift the lid. The steam engine was the result.

Thomas Edison, while developing the light bulb, noticed a peculiar glow at the base of the bulb. He did not then have time to investigate what it was but thought it important enough to patent the effect he had observed. The "Edison effect" later laid the foundation for modern radio and television.

Alexander Fleming, working in his laboratory with cultures of various germs, noticed that in some of his glass dishes the germs were not thriving. He decided to find out why and discovered that a mold was killing the germs. The result of his investigation was penicillin—one of the greatest medical discoveries of all time.

There is a saying among scientists that "Luck favors the trained observer." The same holds true in life in general.



Gather Knowledge

Thinking alone is not enough to keep you “mentally awake.” Thinking won’t help you much unless it is coupled with accurate knowledge.

You absorb much of this knowledge from other people. Your early knowledge you get from your father and mother and from older brothers and sisters. Your Scout leaders have much to give you. So have your schoolteachers.

A foreign visitor once asked three American schoolboys: “Why do you go to school?”

The first schoolboy said, “Because I have to—it’s the law.”

The second said, “Because I want to—all my friends are there.”

The third said, “Because I need to—if I am going to amount to anything.”

Until a few years ago many Americans could truthfully say, “I never had a chance to get an education.” Today America says to every boy and girl, “Here’s your chance for an education—take it!” You have the chance. What you make of it depends on YOU!

Learning New Skills. You have a great help for gathering knowledge and learning new skills in the Scout advancement program. But in addition to Scouting, you need other interests, other hobbies.

Don't choose all your hobbies along the same line. If you're interested in stamp collecting, try to learn something also about radio. If you like wood carving, take a fling at chemistry, too. If you go in for collecting rocks and minerals, make a hobby of swimming or skiing or some other outdoor sport as well. In some of these hobbies, there are merit badges awaiting you when you get good at them.

Reading for a Full Life. Everything you read influences you to some degree. Reading worthwhile things sharpens your mind and helps make your actions clean-cut and sure. Reading trash all the time makes it impossible for anyone to be anything but a second- or third-rate person.

Keep up with what is happening in the world by reading some of the more important items in the daily newspaper and in the weekly news magazines, if you have access to them.

Reading and indoor and outdoor hobbies enrich your life. *Boys' Life* magazine keeps you up to date on Scouting.

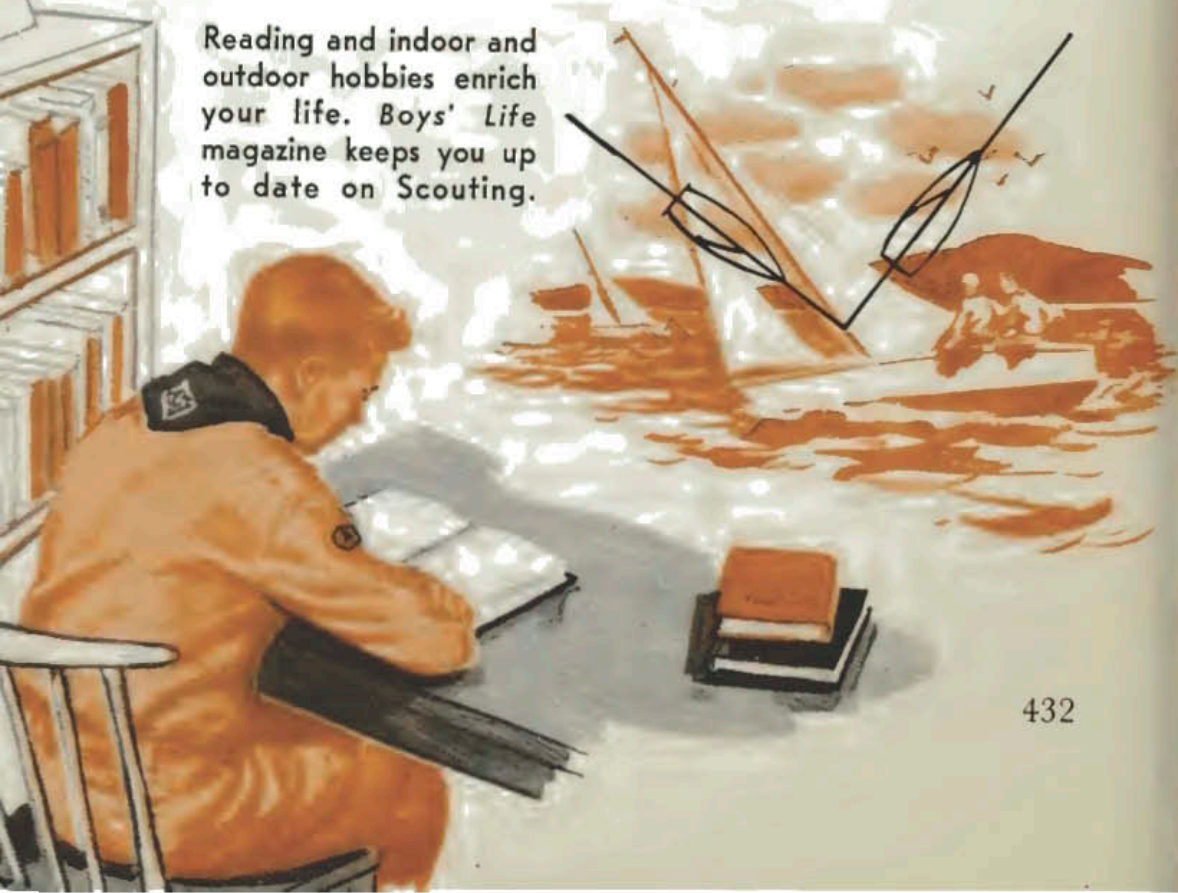

Read a good magazine from time to time. Look into *Boys' Life*, the official magazine of the Boy Scouts of America, for interesting stories and articles, Scouting and hobby features. If you aren't already a subscriber, talk to your Scoutmaster about becoming one.

Start a library of your own, even if you can afford only a few books. Get acquainted with your local librarian and ask for suggestions. Take out a library card. Talk to your schoolteacher and others who may be qualified to advise you about books.

Listening and Looking. What goes for reading goes for radio and records, TV and movies.

Listening for hours to the latest fad in popular music or looking at western and horror movies won't do much to improve your mind. Try a varied diet for a few days, and you'll decide on a better fare.

Radio and television give you a chance to keep up on what is happening in the world, to listen to and to see men and women making history at the very moment they are making it, to become acquainted with the finest music in the world.

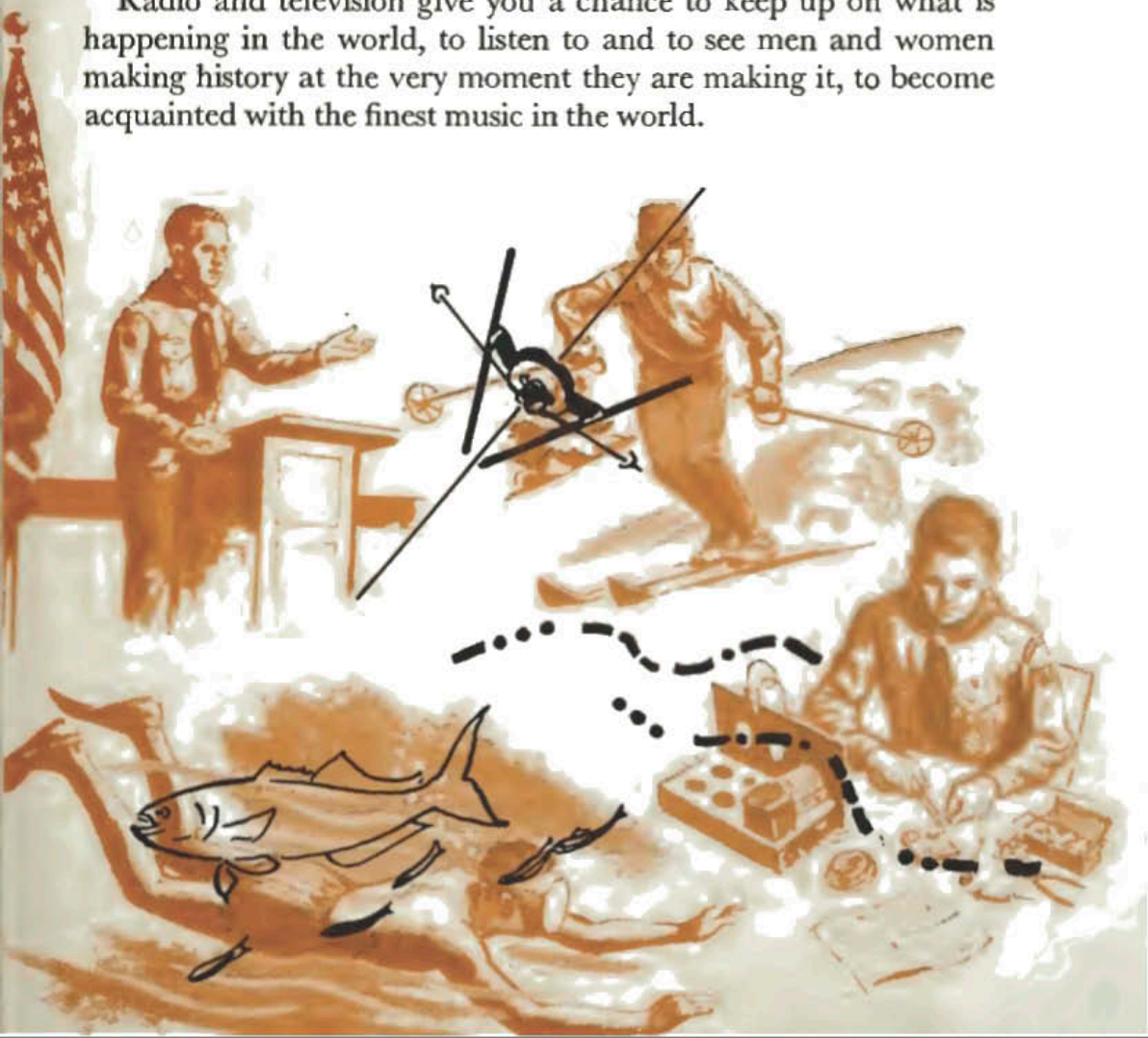

Have Initiative

Thinking is good, knowledge is good, but no man ever gets very far with either if he does not have initiative.

Initiative is the ability to act without being told what to do. The boy with initiative often advances more rapidly than a more brilliant boy who doesn't have initiative. The boy who sits around and waits for somebody to give him directions, who does only what he is told and nothing more, is not going to advance very rapidly or very far.

Begin to exercise initiative right now in your own home. Do things around the house that need to be done, even though no one has told you to do them.

In your schoolwork, don't confine yourself merely to what the teacher tells you to study, but try to learn more about the subject than you find in the textbook.

Show initiative in your patrol and troop, by bringing in suggestions for activities, things to display in your meeting room. Accept responsibility by offering to help out in a Cub Scout den, to get the troop's camp equipment in shape, to investigate new campsites, to run games and contests, to line up new activities. The boy who shows initiative is usually the one who is chosen a leader by his fellow Scouts.

The world will not advance without initiative. Someone has to show it—it might as well be you! You may make mistakes at first. Don't let that worry you—everyone does. Learn your lesson from your mistakes so that you don't make the same mistake twice. Be sure in your mind that you are right—then go ahead!

Control Yourself

"Know thyself" was good advice 2,000 years ago. It's just as good today. The trouble with it is that it is the hardest thing in the world to do.

Know yourself—know what makes you tick. If you know that, you have the answer to what makes the other fellow tick.

There is a constant battle going on inside all of us—a battle between the desire to do certain things or not to do them, to give our best efforts to accomplish something great or to try to get



Show initiative! Practice leadership!

away with things the easy way. Sometimes a fellow feels like kicking up in an outburst of temper—the next moment he is too lazy to do anything. He may be irritated for a good reason or for none at all and show it in a sour spirit. He may hurt someone he loves with thoughtless words or with a silly act. All of us do things like that at one time or another.

The main thing is to be strong enough to suppress those quirks. If you keep yourself “mentally awake” they’ll never have a chance to take over. Sometimes it helps to place yourself, figuratively speaking, outside yourself and try to see yourself as others see you. Then your behavior may strike you as being pretty silly, and you can quickly do something about it.

At times you may have to disagree with other people. Learn to disagree without being disagreeable—there’s an art that takes some learning. If you present your view in a pleasant manner, people will listen. But if you get up on your high horse they’ll feel like knocking you off—and you will have lost your point.

Learn to take anything that comes with a good spirit. Do your best to shut out the things that might annoy you. Forget yourself. Get into the habit of thinking of other people. And keep busy doing interesting things.

Then you’ll have no trouble keeping “mentally awake.” Your life will be so full of things to be explored and lived that there won’t be enough hours in the day to crowd them in.

MORALLY STRAIGHT

Deep within each human being is laid a precious thing, possessed by no other living creature—the thing we call a conscience. No one can tell you where it is located or what it looks like—but it is there just the same. Occasionally, in some people, it seems fast asleep. But in most people it is like an inner voice that is very much awake—sometimes it whispers to you, at other times it seems to yell out loud. It is your conscience that makes it possible for you to distinguish between right and wrong, that helps you follow the right trail through life.

YOUR CONSCIENCE SPEAKS TO YOU OF YOURSELF—of the moral obligation you have to make your life count.

This very moment, while you are still a boy, you must make decisions that will shape the rest of your life. The way you work in school will set the pattern for your future. Failing a subject may close the door forever to the lifework for which you are best suited, where you might possibly be of the greatest benefit to all mankind. Stradivari, the famous violin maker, is supposed to have said, "If my hands slack I would rob God—for God cannot make Stradivarian violins without Stradivari."

YOUR CONSCIENCE SPEAKS TO YOU ABOUT YOUR RELATIONSHIP TO OTHER PEOPLE—respecting their rights, treating them justly, giving them a fair chance. The knights of old were pledged to protect women—it was their duty to keep them from harm. The Scout of today treats women with the same high regard.



YOUR CONSCIENCE TELLS YOU TO OBEY THE LAWS OF OUR COUNTRY. Those laws were created to benefit all our people—to keep them safe in their persons and in their property, to protect them in their homes and on the streets and highways.

"Let your conscience be your guide." Know what is right—do what is right.

ONCE A SCOUT, ALWAYS A SCOUT

From being a boy you are slowly becoming a man. A few years from now you will be a voting citizen of our great country. But before you reach manhood status there is much more Scouting ahead of you.

Most boys who have had a happy Boy Scouting experience want to help the younger boys who are following in their footsteps have just as much Scouting fun as they had. You can be a great influence in the lives of this next generation of Scouts by offering your services to your troop for leadership in troop activities, as a coach in Scoutcraft skills, as a helper in the patrols. Or you may want to look into **EXPLORING** — an older boy program of the Boy Scouts of America.

Eventually, your days as a Boy Scout or an Explorer will be over. But you may want to continue in a close association with Scouting as an adult Scouter — a leader of a Cub Scout pack, a Boy Scout troop, or an Explorer post, or a member of a local committee working for Scouting. Or you may decide—as many young men have done—to make Scouting your lifework by continuing in the Boy Scouts of America as a member of the professional staff.



Becoming a Voting Citizen. But whether you stay on in active Scouting or not, what you have learned as a Scout will be with you always.

When you reach the age of voting citizenship you will know the true meaning of democracy and of liberty and will be able to carry out your duties to your country—obeying its laws, taking your place in the community.

Be a thinking citizen—not a thoughtless one.

Keep yourself informed on the happenings of the day—in your own community, your country, and throughout the world.

Learn how your country, your own State, your city, town, or village are governed and find out how you fit into that government. Discover where that government is strong and where it is weak. Do your part as a citizen in the big task of upholding its strength and overcoming its weaknesses.

But be prepared as well to do your part in the smaller tasks—in such everyday things as obeying traffic regulations, living up to game laws when you go hunting or fishing, serving on jury duty when called, and many other things.

Find out about our political parties and what they stand for—*all* of them, not just one. Study all sides of a question that concerns the welfare of your community, your State, your country. Then take your stand and vote as your conscience bids you. Vote those people into public office you feel best fitted to do what you think is right.

That's the way to make democracy work.

But don't stop there.

Remember that America is not a gift that is freely given us. Each of us must deserve it. We must work for America, live for it, and, if the call should come, die for it!

"A chain is as strong as its weakest link." A nation is as strong as each of its citizens. America is as strong as YOU are!

On hikes and in camp, through climbing and swimming and pioneering, you have developed your body into that of a healthy American—straight-backed, strong.

Your mind has been sharpened as you practiced observation and reasoning, as you mastered new skills, as you learned to go through nature with your eyes wide open.



By following the Scout Oath and the Scout Law you have set a high standard for yourself and have built yourself into the kind of citizen our country needs.

As a man you are able to step forward unflinchingly, take your place with our country's finest, and say with them:

"AMERICA! Here I stand!
My *body* strong to fight your battles!
My *mind* trained to keep your democracy virile!
My *spirit* true to uphold your ideals!
To God and to you I pledge my *service*:

ON MY HONOR, I WILL DO MY BEST . . . !"

BOOKS YOU'LL ENJOY READING

AQUATICS

- Swimming and Diving.* American Red Cross.
Canoeing. American Red Cross.
Canoeing. Carle W. Handel.
Merit badge pamphlets: *Canoeing, Lifesaving, Motorboating, Rowing, Small-Boat Sailing, Swimming.* Boy Scouts of America.
Boys' Life reprint pamphlets: *Boats and Canoes, Swimming and Waterfront Activities.* Boy Scouts of America.

CAMP ACTIVITIES

- The Golden Book of Indian Crafts and Indian Lore.* W. Ben Hunt.
The Book of Indian Crafts and Indian Lore. Julian H. Salomon.
Dances and Stories of the American Indian. Bernard S. Mason.
The Book of Indian-Crafts and Costumes. Bernard S. Mason.
Universal American Indian Sign Language. William Tomkins.
Boy Scout Songbook. Boy Scouts of America.
Knots and How To Tie Them. Boy Scouts of America.
Fun With Ropes and Spars. John Thurman.
Progressive Pioneering. John Thurman.
The Gilwell Camp Fire Book. John Thurman and Rex Hazlewood.
Complete Book of Campfire Programs. LaRue A. Thurston.
Merit badge pamphlets: *Archery, Athletics, Indian Lore, Pioneering, Signaling.* Boy Scouts of America.

CAMPING AND HIKING

- The Golden Book of Camping and Camp Crafts.* Gordon Lynn.
The New Ways of the Wilderness. Calvin Rutstrum.
Complete Book of Camping. Leonard Miracle with Maurice Decker.
Wildwood Wisdom. Ellsworth Jaeger.
The Outdoor Chef. Paul W. Handel.
Jack-Knife Cookery. James Austin Wilder.
Be Expert With Map and Compass—The Orienteering Handbook. Bjorn Kjellstrom.
Merit badge pamphlets: *Camping, Cooking, Hiking, Cycling, Skiing, Surveying.* Boy Scouts of America.

CITIZENSHIP

- The American Adventure.* Bertrand M. Wainger.
Youth Faces American Citizenship. Leo J. Alilunas and J. Woodrow Sayre.
Your Life as a Citizen. Harriet Fullen Smith.
American Heritage Book of Great Historic Places.
Merit badge pamphlet: *Citizenship.* Boy Scouts of America.
Boys' Life reprint pamphlets: *Bill of Rights, Law and Justice, Our Heritage of Freedom.* Boy Scouts of America.

NATURE—GENERAL

- Field Book of Nature Activities and Conservation.* William Hillcourt.
The Golden Book of Nature Crafts. John R. Saunders.
Bird Watching, Housing and Feeding. Walter E. Schutz.
Using Wayside Plants. Nelson Coon.
Animal Tracks and Hunter Signs. Ernest Thompson Seton.
Wild Animals I Have Known. Ernest Thompson Seton.
Trail and Camp-Fire Stories. Julia M. Seton.
Merit badge pamphlets: *Astronomy, Bird Study, Botany, Fishing, Forestry, Geology, Insect Life, Nature, Reptile Study, Soil and Water Conservation, Weather, Wildlife Management.* Boy Scouts of America.
Boys' Life reprint pamphlets: *Fishing, Nature Hobbies and Activities.* Boy Scouts of America.

NATURE—GUIDEBOOKS

- Golden Nature Guides.* Edited by Herbert Zim. Separate volumes on *Mammals, Birds, Reptiles and Amphibians, Seashores, Insects, Flowers, Trees, Rocks and Minerals, Weather, Stars.*
Peterson's Field Guides. Edited by Roger Tory Peterson. Separate volumes on *Mammals, Animal Tracks, Eastern Birds, Western Birds, Amphibians and Reptiles, Shells of Atlantic Coast, Shells of Pacific Coast, Butterflies, Rocks and Minerals, Trees and Shrubs.*
Putnam's Field Books. Separate volumes on *Mammals, Eastern Birds, Birds of the Pacific Coast, Snakes, Ponds and Streams, Seashore Life, Insects, Flowers, Western Flowers, Trees and Shrubs, Rocks and Minerals, Stars.*
Complete Field Guide to American Wildlife. Henry Hill Collins, Jr.

PHYSICAL FITNESS

- Fit for Tomorrow.* Boy Scouts of America.
The Boy's Book of Physical Fitness. Hal G. Vermes.
How To Be Fit. Robert Kiphuth.
Merit badge pamphlets: *Athletics, Hiking, Personal Fitness, Swimming.* Boy Scouts of America.
Boys' Life reprint pamphlet: *Toughen Up.* Boy Scouts of America.

SCOUTING HISTORY

- Baden-Powell—The Two Lives of a Hero.* William Hillcourt with Olave, Lady Baden-Powell.
The Golden Book of Scouting. R. D. Bezucha.
Scouting for Boys. Lord Baden-Powell of Gilwell.

SERVICE TO OTHERS

- Emergency Preparedness BSA.* Boy Scouts of America.
First Aid Manual. American Red Cross.
Merit badge pamphlets: *Firemanship, First Aid, Public Health, Safety.* Boy Scouts of America.

INDEX

A

- Accident prevention, 423
- Accidents; see Emergencies
- Ad Altare Dei, 382
- Adhesive bandage, 197
- Advancement, 96
- Age for joining, 28
- Alabama, 389
- Alaska, 386, 393
- Alpha Omega, 383
- Aluminum foil cookery, 272
- America, 65, 106, 110, 385
 - citizenship, 379, 438
 - hike of, 386
- American's Creed, 398, 403
- Amphibians
 - eft, red, 151; toad, American, 148
- Animal life, 142
- Animals
 - antelope, pronghorn, 147;
 - badger, 159; bear, black, 153; beaver, 155; chipmunk, 146, 147; cottontail, 147; coyotes, 147, 159; deer, black-tailed, 153; deer, mule, 153; deer, whitetail, 150, 154; elk, 152, 153; fox, kit, 158; fox, red, 147; jack-rabbit, blacktail, 158; jackrabbit, whitetail, 146, 159; mice, desert, 159; mink, 148, 149, 154; mole, star-nose, 146; moose, 153; mouse, meadow, 146, 147; mouse, silly pocket, 158; muskrat, 149, 154; opossum, 154; patrol, 38; porcupine, 152, 153; prairie dog, 147; pronghorn antelope, 147; raccoon, 149, 150, 154; rat, kangaroo, 159; rat, pack, 159; skunk, spotted, 159; skunk, striped, 147; squirrel, gray, 146, 151; squirrel, ground, 147, 152, 159; squirrel, red, 152, 153; squirrel, antelope, 159; weasel, longtail, 150; woodchuck, 147
- Ankle, sprained, 204
- Application, Scout, 28, 30
- Aquatics awards, 368
- Arizona, 392
- Arkansas, 389
- Arm sling, 312
- Arterial bleeding, 190
- Artificial respiration, 192

- Assistant patrol leader, 90
- Assistant Scoutmaster, 94
- Assists, 326

Awards

- Certificates for Heroism, 369; Honor Medal, 369; Hornaday Award, 368; Medal of Merit, 369; Order of the Arrow, 369; Religious, 382; Scout Lifeguard, 368, 369

Ax, 172, 259

- care of, 172; chopping with, 174; hand ax, 174; official hand, 174; sharpening, 173; sheath, 173; splitting with, 174-75; use, camp, 253; use, hike, 172

B

- Back fracture, 326

- Bacon, 267

- Baden-Powell, 7, 214-16, 228

- Badge, Scout, 62

- Badges, placement of, 60

Bandages

- adhesive, 197; for foot, 314; for hand, 314; for head, 312; for knee, 314

Bathing, 419

- Bearings, compass, 132

- Bed, 258, 423

- Bee stings, 202, 203

- Beverages, 267, 294

Birds

- bittern, 149; blackbird, red-winged, 149; bunting, indigo, 147; canvasbacks, 154; chickadees, 153; crow, 147, 151; ducks, 149, 154; finches, 153; flycatchers, 159; flycatcher, scissor-tailed, 159; grebes, 148, 155; grosbeaks, 151; grouse, ruffled, 151; gull, herring, 157; hawk, marsh, 149; heron, eastern green, 149; heron, night, 149; jay, blue, 151, 153; jay, Steller's, 152; junco, Oregon, 153; kingfisher, belted, 154; kinglet, 153; lark, meadow, 147; mallard, 149; oriole, 159; osprey, 154; ovenbird, 151; owl, elf, 158,

- 159; owl, great horned, 153; pheasant, 146, 147; pintail, 149; rail, 149; redheads, 154; redstarts, 151; road runner, 158, 159; robin, 147; sandpipers, 157; scaups, 154; sparrow, desert, 158; sparrow, song, 146, 147; swallows, bank, 148; swift, chimney, 146; tanager, scarlet, 146, 151; tanager, Western, 152; teal, 149; tern, common, 157; thrasher, crissal, 159; thrush, wood, 150, 153; towhee, 146, 147; veerie, 151; vireo, red-eyed, 151; vulture, turkey, 147; warblers, 149, 151, 159; woodpecker, Gila, 158; woodpecker, hairy, 150; woodpecker, white-headed, 153; wren, cactus, 158

- Biscuits, 271

- Bites, 202, 203, 316

- Blankets, 258

- Bleeding, 190

- Blister, 202

- Board of review, 101, 229, 364

- Boating, 342

- Books you will like, 440

- Bowline, 78

- Boyce, William D., 213

- Boy Scouts of America, 83

- founding of, 213

- Boys' Life*, 433

- Bravery, 49

- Bread baking, 271

- Breads, 263

- Breakfasts in camp, 266

- Broad-leaved trees, 289

- Buddy plan, 340

- Burns, 200, 201

- Buzzer, 301

- Byrd, Richard E., 357

C

- California, 393

- Calls, patrol, 91

- Campfires, 346

Camping

- bed making, 258; campfires, 346; cooking, 261; cooking equipment, 262; day in summer camp, 337; desert-island, 351; equipment, patrol, 243,

245; equipment, personal, 241; First Class test, 248; food, care of, 259; garbage disposal, 260; health, 259; improvised equipment, 375; Indian, 348; jamborees, 43, 353; making camp, 248; patrol, 107, 335; patrol organization, 232; Philmont, 352; pioneer, 350; primitive, 352; site, 246; summer camp, 336; traveling camps, 352; troop, 95, 336; waste disposal, 260; water, care of, 268; winter, 351
Camporee, 335
Campsites, 246
Canada, 386
Canoeing, 344
Cap, Scout, 114
Carries, 326-29
Cat hole, 125
Cereals, 266
Certificates, 369
Chartered institution, 94
Cheerfulness, 47
Chicken, fried, 273
Chiggers, 202
Church, helping in, 212
Citizenship, 210, 379, 438
Cleanliness, 50, 418
Cleanup, 185, 274
Clothing
 for camp, 241; for hike, 114
Clove hitch, 76
Code
 Morse, 301; outdoor, 82, 394
Coffee, 424
Collarbone fracture, 324
Colorado, 391
Communities of nature, 142
Community, helping in, 210, 333
Compass, 130; bearing, following, 136; bearing, reading, 132; course, 134; directions, 131; points, 130; variations, 131
Compress, 199
Concentration, 427
Conifers, 290
Connecticut, 387
Conservation, 48, 83, 394, 396
Constellations, 284-87
Constipation, 413
Constitution of U.S.A., 399, 402, 403
Contour lines, 127-29
Cooking
 apple, baked, 273; bacon,

267; biscuits, 271; bread making, 271; breakfast, 266; camp, in, 261; cereals, hot, 266; chicken and corn, 273; chicken, fried, 273; chops and tomatoes, 270; cleanup, 274; cocoa, 267; corn, 273; crew, 264; desserts, 274; dinners, 269; eggs, 267; equipment, patrol, 244, 262; equipment, personal, 252; fish, 184; fish and potatoes, 270; foil-broiled steak, 273; fruit, 266, 273; hamburger a la foil, 272; hike, on, 182; kabob, 183; lunches, 268; meat, 269; organization, 264; pancakes, 267; potatoes, 182, 270, 273; pots and pans, 269; pepper steak, 270; puddings, 271; sandwiches, hot, 268; shish kebab, 183; shortcake, 271; soup, 268; steak and potatoes, 269; steak, broiled, 182; steak, cave-man, 183; steak, ground, 269; suppers, 269; tomatoes, fried, 270; twist, 271; without utensils, 182
Cooking, crew, 252, 258, 264
Corn, roast, 272
Council
 National, 30, 218; patrol leaders, 95
Counselors, merit badge, 358
Country
 duty to, 36, 331, 385
Courtesy, 44
 on hike, 124
Court of honor, 101, 229, 366
Crabs
 blue, 156; fiddler, 157; ghost, 157; hermit, 156; horseshoe, 157
Crawl stroke, 298
Cub Scouts, 29, 30, 53, 237, 434
Cuts, 197, 311

D

Declaration of Independence, 399, 401
Delaware, 387
Democracy, 399, 400
Den chief, 53, 237
Desert-island camping, 351
Deserts, 158

Desserts in camp, 271
Dinners in camp, 269
Directions
 by compass, 132; by North Star, 284; by shadow, 139
Diseases, 424
Dishwashing, 274
Distances, measuring, 279, 281
Distress call, 139
Ditching, 256
Doctor, sending for, 186
Dogbite, 316
Dressing, sterile, 198
Drownings, 408
Duty
 to country, 36, 331, 385, 402; to God, 331, 381; to others, 405; to self, 37, 332, 436
"Duty to God" program, 383

E

Eagle palms, 368
Eagle Scout, 356
 advancement to, 355, 361
 requirements, 367
Ears, care of, 421
Edible plants, 292
Edison, Thomas, 379, 430
Eggs, 263, 267
Eight defense plan, 339
Eisenhower, Dwight D., 51
Electric accidents, 407
Elimination, 413
Emergencies, 186
 boat, 343; drownings, 408; electric, 407; fires, 406; floods, 409; ice, 408; live wires, 407; tornadoes, 409
Equipment, 241
 camp, patrol, 243; camp, personal, 241; cooking, patrol, 244; cooking, personal, 263; distribution, 244; hike, personal, 116; hike, special, 117
Evidence of wildlife, 143
Exercise, 413
Exploring, 437
Eyes, 204, 421, 429

F

Fainting, 196
Farina, 266
Fats, 263

Feet, care of, 112, 420
Fields, 146
50-Miler Award, 368
Financing Scouting, 217-18
Fire lays, 180, 181
Fireplaces
 hunters, 265; rock, 264,
 265; trench, 264, 265
Fire
 building on, 406; care
 with, 395; crisscross, 180,
 181; extinguishing, 184,
 185; fire lays, 180, 181;
 flint and steel, 350; forest,
 85; friction, 349; making,
 179; person on fire, 406;
 protection in camp, 260;
 reporting, 406; safety,
 179; site, 179; tepee, 180,
 181; wood, 177
First aid
 ankle, sprained, 204; arti-
 ficial respiration, 192;
 bandages, triangular, 312-
 15; bee sting, 202, 203;
 bleeding, arterial, 190-91;
 blister, 202; broken bones,
 321-25; burns, 200, 201;
 chigger bites, 202; cuts,
 197-99; dogbite, 316;
 dressing, sterile, 198-99;
 eye, object in, 204; faint-
 ing, 196; First Class, 310;
 fractures, 321-25; frost-
 bite, 320; heat exhaus-
 tion, 319; insect bites,
 202; mouth-to-mouth
 breathing, 192; poisoning,
 internal, 194; poisoning,
 skin, 203; poison ivy poi-
 soning, 203; scalds, 200,
 201; scratches, 197-98;
 Second Class, 188; shock,
 195; sling, arm, 312;
 snakebite, 316-19; splints,
 322; stomachache, 320;
 stretchers, 328-29; sun-
 burn, 201; sunstroke,
 320-21; tick bites, 203;
 tourniquet, 190-91; tri-
 angular bandages, 312-
 15; wounds, 311; wounds,
 puncture, 316
First Class advancement,
 230-33
First Class score, 227
First Class tests, 230-33
 ax, 253; bed for camp,
 257; campsite, 246; clean-
 up, 274; clothing for
 camp, 241; cooking break-
 fast, 266; cooking dinner,
 269; equipped for camp,
 241; fire, care of, 260;

fireplace, 265; first aid,
310; food, care of, 259;
lashings, 275; map sketch-
ing, 278; measuring, 279;
Morse code, 301; plants,
edible, 292; service proj-
ects, 237; signaling, 300;
swimming, 296; swim-
ming safety, 296; tent
pitching, 254; waste dis-
posal, 260; water, care of,
259; woodlore, 288
Fish
 bass, calico, 155; blue-
 fish, 156; bullhead, black,
 154; butterfish, 156; cat-
 fish, 155; cookery, 284;
 crappie, 155; mackerel,
 common, 157; muskel-
 lunge, 155; perch, yellow,
 154, 155; pickerel, 155;
 pike, 155; porgy, sheeps-
 head, 156; skate egg case,
 156; sparring, 156; suck-
 er, white, 155; sunfish,
 common, 155; trout,
 brook, 155; trout, brown,
 154; trout, cutthroat, 155
Fish for food, 263
Fitness, 410, 426
 charts, 416-17; mental,
 426; physical, 410
Flag Day, 69-70
Flag of United States of
 America, 65
 care of, 71; carrying, 71;
 days for displaying, 69;
 description, 67; display-
 ing, 72; Flag Day, 69-70;
 flying, 69; folding, 70;
 greeting, 71; history, 67;
 hoisting, 70; honor guard,
 65, 71; respect to, 69;
 saluting, 71
Flavoring, 263
Fleming, Alexander, 430
Flint and steel, fire by, 350
Floods, 409
Florida, 386, 389
Food, 117, 263, 412
Foot bandage, 314
Footgear for hiking, 114
Forearm fracture, 325
Forests, 150, 152
Formation signals, 122
Fort McHenry, 66, 69, 77
Fractures, 321-25
Friction, fire by, 349
Friendliness, 43
From boy to man, 379
Frostbite, 320
Fruit, 263, 266
Fuel, 178
Fuzz sticks, 171

G

Games
 capture the flag, 223;
 deer stalking, 169; far
 and near, 140; hare and
 hounds, 162; nature hunt,
 223; patrol against pa-
 trol, 169; sleeping pirate,
 168; treasure hunt, 221;
 wary wolf, 168; wide
 games, 224; wounded spy,
 162
Garbage disposal, 185, 274
Geological survey, U.S., 127
Georgia, 388
Gilwell Park, 214
God and Country program,
 382
God, duty to, 51, 331, 381
Gold Quill, 300, 368
Good Turns, 53, 210-18,
 332, 405
 National, 109; patrol, 93;
 troop, 94; unknown Scout,
 213
Grand Union Flag, 67-69
Grasses, 146
Grease pit, 260
Greens, edible wild, 292

H

Hair, care of, 420
Hale, Nathan, 49
Hamburger, 272
Hand bandage, 314
Handclasp, Scout, 55
Hands, care of, 419
Hardwoods, 289-91
Hat, Scout, 114
Hawaii, 386, 393
Head bandage, 312
Health in camp, 259
Heat exhaustion, 318-19
Helpfulness, 42
Hiking
 "bog trotting," 148;
 cooking on hike, 182;
 courtesy on hike, 124;
 equipment, patrol, 117;
 equipment, personal, 114;
 fire permission, 124; food,
 117; ideas for, 221; lost-
 child hike, 222; nature
 hunt, 223; patrol, 93,
 107, 221; resting, 119;
 safety cross-country, 120;
 safety on road, 121; Sec-
 ond Class test, 112; sig-
 nals, silent, 122; speed,
 119; troop, 95, 109, 221
Historical museum, 218
Historic Trails Award, 368
Hitchhiking, 124

Hobbies, 432
Home, helping in, 211
Honor Medal, 49, 369
Hornaday Award, 368, 369
"Hurry cases," 188

I

Ice rescues, 408
Idaho, 391
Illinois, 390
Indiana, 390
Indian camping, 348
Indians, 126, 160, 162-63
costume, 348
Initiative, 434
Insect bites, 202
"In the Name of God"
program, 383
Investiture, Tenderfoot, 31
Iodine, for water
purification, 125
Iowa, 390

J

Jacket, Scout, 116
Jamborees, 43, 216, 353
Jellyfish, 157
Johnston Historical
Museum, 218
Joining, 28

K

Kabob, 183
Kansas, 390
Kentucky, 388
Key, Francis Scott, 67, 69
Kindling, 178
Kindness, 45
Knee bandage, 314
Knife
care of, 170; sharpening,
170; sheath knife, 170;
using, 171
Knots
bowline, 78; clove hitch,
77; half hitch, 75; over-
hand, 75; sheet bend, 76-
77; square knot, 80-81;
taut-line hitch, 80-81; two
half hitches, 78-79
Knowledge gathering, 431

L

Lakes, 154
Landmarks, 133, 135-37
Lashings, 275-77
Latrine, 125, 256, 260
Law, Scout; see Scout Law

Leadership, 434
Leggings, Scout, 115
Lifesaving, 49, 340
Life Scout
advancement to, 361; re-
quirements, 365
Light signaling, 302
Lincoln, 51, 379, 399
Lizards, 159
Lost, what to do, 137
Louisiana, 389
Lower leg fracture, 325
Loyalty, 41
Lunches in camp, 268

M

Maine, 387
Map index circular, 127
Maps
contour lines, 127-29; dis-
tances, 127; mapping,
278; orienting, 133-34;
quadrangles, 127; scales,
127; symbols 129; topo-
graphic, 127; using map,
133
Map sketch, 278
Marshes, 148
Maryland, 387
Massachusetts, 387
Masturbation, 425
Measuring steps, 281
Meat, 263, 268, 283
Medal of Merit, 369
Medical examination,
339, 411
Meetings, 93, 95, 107, 109
Mentally awake, 426, 435
Merit badges, 108, 357-60,
370-77
Merit badge sash, 61, 360-
61
Messages, 186-87
Michigan, 390
Mile Swim BSA emblem,
368
Milk, 263, 266
Minnesota, 390
Mississippi, 389
Missouri, 389
Mollusks
chitons, 157; clam, razor,
157; clam, soft-shell, 156;
mussel, blue, 157; oyster,
157; periwinkles, 156,
157; scallop, bay, 156;
snails, 156; whelk, chan-
neled, 156; whelk, left-
handed, 156
Money
earning, 48; saving, 48
Montana, 391
Morally straight, 436

Morse code, 301-306
Morse, Samuel, 300
Motto, Scout, 52
Mouth-to-mouth breathing,
192-94
Movies, 433
Muscles, 418
Museum, 218

N

Narcotics, 424
National anthem, 66
National Council, 218
Natural resources, 48, 83-87
Nature communities, 142
Nature hunt, 223
Nebraska, 390
Neckerchief, putting on, 59
Neck fracture, 326
Ner Tamid program, 383
Nevada, 393
New England, 386
New Hampshire, 387
New Jersey, 387
New Mexico, 392
New York, 387
North
by compass, 130; by
North Star, 284; by shad-
owless shadow-stick, 139;
magnetic 131, 134; true,
131, 134
North Carolina, 388
North Dakota, 390
North Star, 284-87
Nose, 422
Nourishment, 412

O

Oath, Scout; see Scout Oath
Oatmeal, 266
Obedience, 46
Observation, 140, 429
Ohio, 390
Oklahoma, 392
Old Glory, 68, 69
Order of the Arrow, 368
Oregon, 393
Orienting map
by compass, 134; by in-
spection, 133
Outdoor Code, 82-87

P

Packing, 251
Packs, 250, 251
Paddling, 344-45
Page, William Tyler, 399
Pancakes, 267
Pathfinder compass, 132

Patrol
activities, 88, 234; call, 91, 92; campfires, 346; camp making, 252; camporee, 335; cooperation, 235; emblem, 92; equipment, camp, 244-45; equipment, hike, 117; flag, 92; Good Turns, 93; hikes, 93, 107; jobs, 90; leader, 89; medallion, 92; meetings, 93, 107; name, 90, 91; service projects, 107; signature, 90, 91; totem, 90, 91

Patrol leader, 89

Patrol leaders' council, 95

Pennsylvania, 387

Philmont, 352

Physically strong, 410

Pioneer camping, 350

Pioneers, 110, 350

Plant life, 142, 144, 145

Plants

algae, 157; arrowhead, 293; bergamot, wild, 294; bittersweet, 151; blackcap, 295; blueberry, 153, 295; burdock, 290, 293, 294; cactus, barrel, 159; cactus, beaver-tail, 159; cactus, saguaro, 158; cattails, 148, 149, 154, 293; century plant, 159; chicory, 292, 293; cholla, staghorn, 158; cholla, Teddy bear, 159; cranberry, 295; cress, water, 292; cucumber, Indian, 283; dandelion, 292; dewberry, 295; dock, curled, 293; edible wild, 292; celgrass, 155; evening primrose, 294; grape, wild, 151, 295; grass, beach, 156; grass, chufa, 293, 294; grasses, 146; groundnut, 293, 294; hornwort, 154; huckleberry, 153, 295; Irish moss, 157; Jerusalem artichoke, 294; lamb's-quarters, 292, 293; marigold, marsh, 292, 293; May apple, 295; milkweed, 293; mustard, black, 293; nettle, stinging, 293; ocotillo, 159; peanut, hog, 293, 294; peppermint, 294; poisonous, 124; pokeweed, 293; prairie apple, 293; prickly pear, 159, 295; purslane, 292, 293; raspberry, red, 295; reeds, 149, 154;

rockweed, 156; sea lettuce, 156; sea moss, 156; seaweed, 157; sedges, 148, 154; sorrel, sheep, 292, 293; spearmint, 294; strawberry, wild, 295; sweetbrier, 295; waterweed, 154; wintergreen, 294; yucca, 158

Pledge of allegiance, 65

Poisoning

internal, 194; poison ivy, 203; skin, 203

Poison ivy, 141, 142, 203

Poison oak, 141, 142

Poison plants, 141

Poison sumac, 141

Polaris, 284

Portuguese man-of-war, 157

Posture, 408

Potatoes

baked, 182; boiled, 270; Lyonnaise, 273

Poultry, 273

Prairies, 146

Pro Deo et Patria program, 382

Promise, Scout; see Scout Oath

Puddings, 271

Puerto Rico, 386

Puncture wounds, 316

Q

Quadrangles, 127

Queen Anne flag, 67, 68

R

Radio, 433

Reading, 432

Records, 433

Registration card, 29

Religion in Life program, 383

Religious programs, 382-83

Reptiles; see Snakes, Lizards, Turtles

Requirements

Eagle Scout, 367; First Class Scout, 230; Life Scout, 365; Second Class Scout, 102; Star Scout, 363; Tenderfoot Scout, 34

Rescue breathing, 192-93

Rescues, 408

Resources, natural, 83

Rest, 119, 422

Reverence, 51

Review, 101, 229, 364

Revolutionary War, 48, 65, 66, 67, 69, 94, 110

Rhode Island, 387

Rivers, 154

Roosevelt, Theodore, 379

Roots, edible wild, 293

Rope, parts of, 75

Rowing, 342

S

Safe Swim Defense, 339

Safety

boat, 342; on hike, 120; swimming, 296, 339

Salute, Scout, 55

Sandwiches, 268

Sangha program, 383

Savings bonds, 48

Savings stamps, 48

Scalds, 200, 201

Scales, map, 127

School, 212, 431

Scout advancement, 96

Scout awards; see Awards

Scout badge, 62

Scout distributors, 58, 117

Scout handclasp, 55

Scout hat, 114

Scout Law, 38, 207, 404, 425, 439

Scout Lifeguard, 368, 369

Scout motto, 52

Scout Oath, 31, 36, 37, 209, 330-32, 379-80, 439

Scout Promise; see Scout Oath

Scout salute, 54, 55

Scout service, 437

Scout sign, 54

Scout signals, 122

Scout slogan, 53

Scout uniform

care of, 59; for camping, 241; for hiking, 115; when to wear, 59

Scratches, 197

Seashore, 156

Second Class advancement, 100, 101

Second Class score, 99

Second Class tests, 102

animal life, 142; ax, 172; cleanup on hike, 185; clothed for hike, 115; compass, 130; compass course, 135; compass, using, 133; cooking on hike, 182; equipped for hike, 114; feet, care of, 114; fire lighting, 180; fire site, 179; firewood, 177; first aid, 188; knife, 170; latrine, 125; lost, what to do, 137; map, following, 134; map, orienting, 133; map symbols, 129; nature communities, 142; nature exploration, 142; plant

life, 142; plants, poison, 141; safety, cross-country, 120; safety on highway, 121; signals, silent, 122; stalking, 166; tracking, 163; trailing, 161; walking correctly, 118; water on hike, 125

Senior patrol leader, 94

Service, 437

 First Class, 330; Second Class, 207

Service projects, 107, 210, 237, 362

Shadowless shadow-stick, 139

Sheet bend, 76

Shelter, 139

Shirt, Scout, 115

Shish kebab, 183

Shock, 195

Shoes, Scout, 114

Shrubs

 bayberries, 156; beach-plum, 156; hazel, 295; knowing, 288; spicebush, 294

Sign, Scout, 54

Signaling, 300

 by buzzer, 301; by flags, 304; by light, 302; by sound, 302; importance of, 300; procedure signals, 303; semaphore, 307; sending message, 304; signal station, 300; wigwag, 304

Signals

 distress, 139; ok, 139; signaling, 300; silent, 122

Signature, patrol, 90, 91

Signs

 feeding, 163; Indian trail, 162; tracks, 163; trail, 161

Silent signals, 122

Silver Buffalo Award, 214

Siple, Paul, 357

Sleep, 422, 423

Sleeping bags, 258

Sling, arm, 312

Slogan, Scout, 53

Smoking, 424

Snakebite, 316-19

Snakes

 racer, black, 146, 147; rattler, diamondback, 159; ringneck, 151; sidewinder, 158, 159; watersnake, 149

Socks, Scout, 115

Softwoods, 289

Sound signaling, 302

Soup, 268

South Carolina, 388

South Dakota, 390

Splints, 322

Square knot, 80

Stalking, 166-69

Starfish, 156

Stars, 284-87

Star Scout, 357

 advancement to, 361; requirements, 363

 "Star-Spangled Banner," The, 66

Star-Spangled Banner, 68, 69

Steak, 182, 183, 269, 270

Step course, 281

Steps, length of, 281

Stew, 272

Stimulants, 424

Stockings, Scout, 115

Stomachache, 320

Streams, 154

Stretchers, 328

Succession, plant life, 144-45

Summer camp, 95, 336

Sunburn, 201

Sun, directions with, 139

Sun stroke, 319, 320

Suppers in camp, 269

Swamps, 148

Sweater, Scout, 116

Sweets, 263

Swimming, 296

 crawl stroke, 298; First Class test, 296, 299; learning to, 297; rescue, 340; safety, 296

Symbols, map, 129

T

Tanning, 421

Taut-line hitch, 80, 81

Tea, 424

Teeth, care of, 420

Telephone message, 186

Television, 433

Tenderfoot

 "Tenderfoot," 100

 investiture, 31

Tenderfoot score, 33

Tenderfoot tests, 34

 advancement, 96; flag, displaying, 69; flag, history, 67; flag, respect, 69; knots, 74; leaders, troop, 94; natural resources, 83; patrol call, 41; patrol name, 90; patrol yell, 90; pledge of allegiance, 65; Scout badge, 62; Scout handclasp, 55; Scout Law, 38; Scout motto, 52; Scout Oath, 36, 37; Scout salute, 54, 55; Scout sign, 54; Scout slogan, 53;

Scout uniform, 56; whipping, 75

Tennessee, 388

Tenting crew, 252

Tents

 camper, 243; ditching, 256; Explorer, 243; pegs, 254, 255; pitching, 254-57; poles, 254; site, 254

Tests

 First Class, 230; Second Class, 102; Tenderfoot, 34

Texas, 392

Thigh, fracture, 324

Thrift, 48

Ticks, 203

Tinder, 177, 178

Tobacco, 424

Tomatoes, fried, 270

Topographic maps, 127

Tornadoes, 409

Tourniquet, 190-91

Tracking, 163-65

Tracks, 164

Trailing, 161-62

Trails awards, 368

Trail signs, 161, 162-63

Traveling camps, 352

Treasure hunt, 221

Trees

 ash, green, 291; ash, white, 150; aspen, quaking, 153, 291; balsam, 152, 290; basswood, 294; beech, 151; birch, black, 294; birch, gray, 153, 290; broad-leaved, 289; butternut, 295; cedar, red, 291; chestnut, 295; conifers, 150, 289; cottonwood, 146; cypress, 148; dogwood, 151, 288; Douglas fir, 152; elderberry, 294; elms, 288; fir, balsam, 290; gum, sweet, 288; hardwoods, 150; hemlock, 152; hickory, 150, 290, 295; holly, 288; knowing, 288; locust, 288; magnolia, 288; maple, 288; maple, red, 147; maple, sugar, 151, 273, 290; oak, 150, 288; oak, live, 291; oak, white, 150, 290; papaw, 295; pecan, 295; persimmon, 295; pine, 152, 156, 290; pine, Digger, 295; pine, eastern white, 150, 290; pine, lodgepole, 153; pine, western white, 152; piñon, 295; poplar, 273; redbud, 151, 288; sassafras, 151, 288; spruce,

152, 288; spruce, black, 290; sumac, poison, 141, 142; sumac, staghorn, 294; sycamore, 288; tamarack, 148; tulip, 288; walnut, black, 295; willow, black, 291; willow, weeping, 155
Triangular bandages, 312-15
Troop
 campfires, 336, 346;
 camps, 95; colors, 94;
 committee, 94; cooperation, 108, 235; court of honor, 101, 229, 366;
 Good Turns, 94; hikes, 95, 109, 208, 209; leaders, 94; meetings, 95, 109; service projects, 109, 237; summer camp, 336
Trustworthiness, 40
Twist, 271
Two half hitches, 78, 79
Turtles, 148, 150

U

Uniform, Scout
 care of, 59; for camp,

241; for cool weather, 115; for hiking, 116; for hot weather, 115; purchase, 58; rules for wearing, 59; significance, 56
United States of America;
 see America
 flag of, 65; motto, 51;
 savings bonds, 48; savings stamps, 48
Unknown Scout, 213-14
Upper arm fracture, 324
Utah, 391

V

Vegetables, 263
Vermont, 387
Virginia, 388

W

Walking, 118, 417
Washington, D. C., 400
Washington, George, 46, 67, 379, 399
Washington, State of, 393

Waste disposal, 260
Water
 accidents, 408; drinking, 414; in camp, 268; on hike, 125
Watt, James, 430
Webelos, 30
West Virginia, 388
"Wet dream," 425
Whifflepoof, 165
Whipping, 75
Who pays for Scouting, 217-18
Wigwag, 304
Wildlife, 142
Winter camping, 351
Wires, electric, 407
Wisconsin, 390
Wood, 288
 chopping, 174; for fire, 177; splitting, 175
Woodlands, 288
 eastern, 150; evergreen, 152
Woodlore, 288
World jamborees, 353
Wounds, 311
 puncture, 316
Wyoming, 391

DEN CHIEF'S CORD
WORN ON RIGHT
SHOULDER

SHOULDER SEAM



2"

2"

4"



PATROL
MEDALLION



BADGE OF
OFFICE

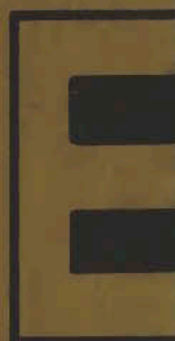

RIGHT SLEEVE

LEFT SLEEVE



Books-Man/RefEd
 4 13929 00000 4
 Books-Pink-21 206-091009
 arc

\$1.99

DO A GOOD TURN DAILY